

Transnet Freight Rail, a division of

TRANSNET SOC LTD

Registration Number 1990/000900/30

[hereinafter referred to as **Transnet**]

REQUEST FOR QUOTATION [RFQ] No CRAC DNR 22862

FOR THE SUPPLY AND DELIVERY OF: FLOODLIGHTS

FOR DELIVERY TO: 130 EEL ROAD, BAYHEAD, DURBAN

ISSUE DATE: 2 NOVEMBER 2016

CLOSING DATE: 8 NOVEMBER 2016

CLOSING TIME: 12:00

VALIDITY PERIOD: 19 MARCH 2017

Section 1
NOTICE TO BIDDERS

1 Invitation to bid

DESCRIPTION	Supply and Delivery of Floodlights at 130 Eel Road, Bayhead, Durban
BID FEE AND BANKING DETAILS	R250.00 [inclusive of VAT] per set. Payment is to be made as follows: Account Name : Transnet Freight Rail Account : Standard Bank Account number : 203158598 Branch code : 004805 NOTE – This amount is not refundable. A receipt for such payment made must be presented when collecting the RFP documents and submitted thereafter with your Proposal.
INSPECT / COLLECT DOCUMENTS FROM	This bid may be downloaded free of charge directly from the Transnet Freight Rail tender website at; http://www.transnetfreightrail-tfr.net/Supplier/Pages/Tenders.aspx Alternatively, this RFQ may be purchased at R250 [inclusive of VAT] per set for those Bidders that require a copy from Transnet rather than downloading from the website. If a copy of the tender document is required, prior arrangements must be made one (1) day in advance and the tender document may be collected between 09:00 and 15:00 from 2 November 2016 until 7 November 2016 This RFQ may be picked up from the following address: RECEPTION, TENDER OFFICE, 100 EEL ROAD, BAYHEAD, DURBAN.
COMPULSORY/NON COMPULSORY BRIEFING SESSION	A formal briefing session <u>will not be held</u> but should Respondents have specific queries they should email these to the Transnet employee(s) indicated in paragraph 6 [<i>Communication</i>] below:
CLOSING DATE	12:00 on Tuesday 8 November 2016 This tender shall close punctually at the following address: The Chairperson, Transnet Freight Rail Acquisition Council, 100 Eel Road, Bayhead, Durban As a general rule, if a bid is late or delivered to the incorrect address, it will not be accepted for consideration.
VALIDITY PERIOD	90 Business Days from Closing Date. End of validity period: 19 March 2017 Bidders are to note that they may be requested to extend the validity period of their bid, on the same terms and conditions, if the internal evaluation process has not been finalised within the validity period.
SPECIAL CONDITIONS	Bidders are to note that this bid may also be downloaded directly from the Transnet Freight Rail tender website free of charge. If Bidders intend to download the bid off the Portal, they are required to indicate their intention to respond to this bid by 7 November 2016 by sending an email with their contact details to the following address: Mduduzi.khoza@transnet.net OR Nonzame.mashalaba@transnet.net This is to ensure that any required communication (e.g. addenda to the bid) in relation to this bid reaches those intending to respond. Transnet will not be held liable if Bidders do not respond by this date and do not receive the latest information regarding this Bid as a result thereof.

2 Responses to RFQ

Responses to this RFQ [**Quotations**] must not include documents or reference relating to any other quotation or proposal. Any additional conditions must be embodied in an accompanying letter.

8 Prices Subject to Confirmation

Prices quoted which are subject to confirmation will not be considered.

9 Binding Offer

Any Quotation furnished pursuant to this Request shall be deemed to be an offer. Any exceptions to this statement must be clearly and specifically indicated.

10 Disclaimers

Transnet is not committed to any course of action as a result of its issuance of this RFQ and/or its receipt of a Quotation in response to it. Please note that Transnet reserves the right to:

- modify the RFQ's goods / service(s) and request Respondents to re-bid on any changes;
- reject any Quotation which does not conform to instructions and specifications which are detailed herein;
- disqualify Quotations submitted after the stated submission deadline;
- not necessarily accept the lowest priced Quotation or an alternative bid;
- reject all Quotations, if it so decides;
- place an order in connection with this Quotation at any time after the RFQ's closing date;
- award only a portion of the proposed goods / service/s which are reflected in the scope of this RFQ;
- split the award of the order/s between more than one Supplier/Service Provider should it at Transnet's discretion be more advantageous in terms of, amongst others, cost or developmental considerations;
- make no award at all;
- validate any information submitted by Respondents in response to this bid. This would include, but is not limited to, requesting the Respondents to provide supporting evidence. By submitting a bid, Respondents hereby irrevocably grant the necessary consent to Transnet to do so;
- request audited financial statements or other documentation for the purposes of a due diligence exercise; and/or
- not accept any changes or purported changes by the Respondent to the bid rates after the closing date and/or after the award of the business, unless the contract specifically provides for it.

Should a contract be awarded on the strength of information furnished by the Respondent, which after conclusion of the contract, is proved to have been incorrect, Transnet reserves the right to cancel the contract and/or place the Respondent on Transnet's list of Restricted Suppliers.

Transnet reserves the right to award business to the highest scoring bidder/s unless objective criteria justify the award to another bidder.

Transnet reserves the right to undertake post-tender negotiations [PTN] with selected Respondents or any number of short-listed Respondents, such PTN to include, at Transnet's option, any evaluation criteria listed in this RFQ document. In the event of any Respondent being notified of such short-listed/preferred bidder status, his bid, as well as any subsequent negotiated best and final offers (BAFO), will automatically be deemed to remain valid during the negotiation period and until the ultimate award of business.

Should the preferred bidder fail to sign or commence with the contract within a reasonable period after being requested to do so, Transnet reserves the right to award the business to the next highest ranked bidder, provided that he/she is still prepared to provide the required goods at the quoted price.

Under such circumstances, the validity of the bids of the next ranked bidder(s) will be deemed to remain valid, irrespective of whether the next ranked bidder(s) were issued with a Letter of Regret. Bidders may therefore be requested to advise whether they would still be prepared to provide the required goods at their quoted price, even after they have been issued with a Letter of Regret.

11 Specification/Scope of Work

See Annexure A : Description of Work

12 Legal review

A Proposal submitted by a Respondent will be subjected to review and acceptance or rejection of its proposed contractual terms and conditions by Transnet's Legal Counsel, prior to consideration for an award of business.

13 Security clearance

Acceptance of this bid could be subject to the condition that the Successful Respondent, its personnel providing the goods and its subcontractor(s) must obtain security clearance from the appropriate authorities to the level of CONFIDENTIAL/ SECRET/TOP SECRET. Obtaining the required clearance is the responsibility of the Successful Respondent. Acceptance of the bid is also subject to the condition that the Successful Respondent will implement all such security measures as the safe performance of the contract may require.

14 National Treasury's Central Supplier Database

Respondents are required to self-register on National Treasury's Central Supplier Database (CSD) which has been established to centrally administer supplier information for all organs of state and facilitate the verification of certain key supplier information. Transnet is required to ensure that price quotations are invited and accepted from prospective bidders listed on the CSD. Business may not be awarded to a Respondent who has failed to register on the CSD. The CSD can be accessed at <https://secure.csd.gov.za/>. Respondents are required to provide the following to Transnet in order to enable it to verify information on the CSD:

Supplier Number: _____ Unique registration reference number: _____.

15 Tax Compliance

Regulation 14 of the Preferential Procurement Regulations, 2011 issued in terms of the Preferential Procurement Policy Framework Act (PPPFA) states that no tender may be awarded to any person whose tax matters have not been declared by the South African Revenue Services (SARS) to be in order.

15.1 New Tax Compliance Status (TCS) System

SARS has implemented a new Tax Compliance Status (TCS) system in terms of which a taxpayer is now able to authorise any 3rd party to verify its compliance status in one of two ways: either through the use of an electronic access PIN, or through the use of a Tax Clearance Certificate obtained from the new TCS system.

Respondents are required to provide the following to Transnet in order to enable it to verify their tax compliance status:

Tax reference number: _____
Tax Clearance Certificate & TCC Number: _____ and PIN: _____.

15.2 Tax Compliance Requirements for Foreign Entities

Tax compliance requirements are not applicable to foreign bidders/individuals with no South African tax obligations. Where foreign bidders seek to be exempted from the requirement to submit a tax clearance certificate / tax clearance PIN issued by SARS, such entities are required to complete a sworn affidavit on their tax obligation categorization. The affidavit must confirm an answer of "No" to **all** questions below in order for a Respondent to be regarded as being exempt from submitting a tax clearance certificate or tax clearance PIN:

- a) Is the entity a tax resident of the Republic of South Africa (RSA)?
- b) Does the entity have a branch/locally registered entity in the RSA?
- c) Does the entity have a permanent establishment in the RSA?
- d) Does the entity have any source of income (income is defined as per the Income Tax Act 58 of 1962 as the amount remaining of the gross income of any person for any year or period of assessment after deducting therefrom any amounts exempt from normal tax under Part I of Chapter II of the Act) in the RSA in the current tax year?
- e) Is the entity liable in the RSA for any form of taxation in the current tax year?

If a Respondent's answers to any one (or more) of the questions above changes to a "Yes" at any time during the bid process and/or after award of the contract (should a particular Respondent be successful), then the Respondent undertakes to comply with its tax obligations and to report to Transnet accordingly with either a tax clearance certificate / tax clearance PIN issued by SARS.

16 Protection of Personal Data

In responding to this bid, Transnet acknowledges that it may obtain and have access to personal data of the Respondents. Transnet agrees that it shall only process the information disclosed by Respondents in their response to this bid for the purpose of evaluating and subsequent award of business and in accordance with any applicable law. Furthermore, Transnet will not otherwise modify, amend or alter any personal data submitted by Respondents or disclose or permit the disclosure of any personal data to any Third Party without the prior written consent from the Respondents. Similarly, Transnet requires Respondents to process any personal information disclosed by Transnet in the bidding process in the same manner. The detailed mutual duties of Transnet and the Respondents to protect personal information is contained in paragraph 37 of the General Bid Conditions.

Transnet urges its clients, suppliers and the general public to report any fraud or corruption to

TIP-OFFS ANONYMOUS: 0800 003 056

RFQ FOR THE SUPPLY AND DELIVERY OF FLOODLIGHTS AT 130 EEL ROAD, BAYHEAD, DURBAN

CLOSING VENUE:100 EEL ROAD, BAYHEAD, DURBAN

CLOSING DATE & TIME :8 NOVEMBER 2016

VALIDITY PERIOD:90 (NINETY) Business Days

SECTION 2
EVALUATION CRITERIA AND RETURNABLE DOCUMENTS

1 Evaluation Criteria

Transnet will utilise the following criteria [not necessarily in this order] in choosing a Supplier/Service Provider, if so required:

Criterion/Criteria	Explanation
Administrative responsiveness	<ul style="list-style-type: none"> • Completeness of response and returnable documents • Submission of Mandatory Documents / Schedules • Submission of Essential Documents / Schedules • Submission of Other Documents / Schedules • All pages of the tender submission is signed by the Bidder/Respondent
Substantive responsiveness	<ul style="list-style-type: none"> • Prequalification criteria, if any, must be met and • Whether the Bid materially complies with the scope and/or specification given without any material deviations or qualifications. <p style="text-align: center;">(Annexure B)</p>
Final weighted evaluation based on 80/20 preference point	<ul style="list-style-type: none"> • Pricing and price basis [firm] • B-BBEE status of company - Preference points will be awarded to a bidder for attaining the B-BBEE status level of contribution in accordance with the table indicated in Section 6 : B-BBEE Claim Form.

2 Validity Period

Transnet desires a validity period of 90 [ninety] Business Days from the closing date of this RFQ.

Bidders are to note that they may be requested to extend the validity period of their bid, on the same terms and conditions, if the internal evaluation process has not been finalised within the validity period. However, once the adjudication body has approved the process and award of the business to the successful bidder(s), the validity of the successful bidder(s)' bid will be deemed to remain valid until a final contract has been concluded.

With regard to the validity period of short-listed bidders, please refer to Section 1, paragraph 9.

This RFQ is valid until _____.

3 Disclosure of Prices Quoted

Respondents are to note that, on award of business, Transnet is required to publish the tendered prices and preferences claimed of the successful and unsuccessful Respondents *inter alia* on the National Treasury e-Tender Publication Portal, (www.etenders.gov.za), as required per National Treasury Instruction Note 01 of 2015/2016.

4 Returnable Documents

Returnable Documents means all the documents, Sections and Annexures, as listed in the tables below.

All Returnable Sections, as indicated in the header and footer of the relevant pages, must be signed, stamped and dated by the Respondent.

a) Respondents are required to submit with their Quotations the **Mandatory Returnable Documents**, as detailed below.

Failure to provide all these Mandatory Returnable Documents at the Closing Date and time of this RFQ will result in a Respondent's disqualification. Respondents are therefore urged to ensure that all these Documents are returned with their Quotations.

Please confirm submission of these mandatory Returnable Documents by so indicating [Yes or No] in the tables below:

Mandatory Returnable Documents	Submitted [Yes or No]
SECTION 3 : Quotation Form ANNEXURE B : Compliance to Specification	

b) **Essential Returnable Documents**

In addition to the requirements of section (a) above, Respondents are further required to submit with their Proposals the following **Essential Returnable Documents** as detailed below.

Essential Returnable Documents required for evaluation purposes:

Failure to provide all Essential Returnable Documents used for purposes of scoring a bid, by the closing date and time of this bid will not result in a Respondent's disqualification. However, Bidders will receive an automatic score of zero for the applicable evaluation criterion. Bidders are therefore urged to ensure that all these documents are returned with their Proposals.

Please confirm submission of these essential Returnable Documents by so indicating [Yes or No] in the table below:

ESSENTIAL RETURNABLE DOCUMENTS USED FOR SCORING	SUBMITTED [Yes or No]
- Valid and original (or a certified copy) proof of Respondent's compliance to B-BBEE requirements stipulated in Section 6 of this RFQ:	

Other Essential Returnable Documents:

Failure to provide other essential Returnable Documents may result in a Respondent's disqualification. Bidders are therefore urged to ensure that all these documents are returned with their Proposals.

Please confirm submission of these essential Returnable Documents by indicating Yes or No in the table below:

OTHER ESSENTIAL RETURNABLE DOCUMENTS & SCHEDULES	SUBMITTED [Yes or No]
Tax Clearance Certificate or electronic access PIN obtained from SARS's new Tax Compliance Status (TCS) system [Consortia / Joint Ventures must submit a separate Tax Clearance Certificate for each party]	
SECTION 4: Certificate of Acquaintance with RFQ Documents	
SECTION 5: RFQ Declaration and Breach of Law Form	
SECTION 6: B-BBEE Preference Claim Form	

5 CONTINUED VALIDITY OF RETURNABLE DOCUMENTS

The successful Respondent will be required to ensure the validity of all returnable documents, including but not limited to its Tax Clearance Certificate and valid B-BBEE Verification Certificate, for the duration of any contract emanating from this RFQ. Should the Respondent be awarded the contract [**the Agreement**] and fail to present Transnet with such renewals as and when they become due, Transnet shall be entitled, in addition to any other rights and remedies that it may have in terms of the eventual Agreement, to terminate such Agreement forthwith without any liability and without prejudice to any claims which Transnet may have for damages against the Respondent.

SECTION 3

QUOTATION FORM AND CERTIFICATE OF ACQUAINTANCE WITH RFQ DOCUMENT

I/We _____
hereby offer to supply the goods/services at the prices quoted in the Price Schedule below, in accordance with the conditions related thereto.

I/We agree to be bound by those terms and conditions in:

- the Standard RFQ Terms and Conditions for the Supply of Goods or Services to Transnet
- any other standard or special conditions mentioned and/or embodied in this Request for Quotation.

I/We accept that unless Transnet should otherwise decide and so inform me/us, this Quotation [and, if any, its covering letter and any subsequent exchange of correspondence], together with Transnet’s acceptance thereof shall constitute a binding contract between Transnet and me/us. I/We further agree that if, after I/we have been notified of the acceptance of my/our Quotation, I/we fail to deliver the said goods/service/s within the delivery lead-time quoted, Transnet may, without prejudice to any other legal remedy which it may have, cancel the order and recover from me/us any expenses incurred by Transnet in calling for Quotations afresh and/or having to accept any less favourable offer.

Price Schedule

I/We quote as follows for the goods required, on a “delivered nominated destination” basis, excluding VAT:

Item No	Description of Goods /Services	Unit of Measure	Quantity	Unit Price (ZAR)	Total Price (ZAR)
1	600w/9000 Lumen HPS wide beam complete with lamps	Each	31		
2	1000w/130000 Lumen HPS wide beam complete with lamps	Each	3		
3	Genlux 400w Odyssey (or similar) Floodlights complete with tubes	Each	18		
TOTAL PRICE, exclusive of VAT:					
VAT (if applicable)					
Total Inclusive of VAT (where applicable)					

Delivery Lead-Time from date of purchase order: _____ [days/weeks]

Notes to Pricing:

- All Prices must be quoted in South African Rand, exclusive of VAT
- To facilitate like-for-like comparison bidders must submit pricing strictly in accordance with this price schedule and not utilise a different format. Deviation from this pricing schedule could result in a bid being disqualified.

Respondent’s Signature

Date & Company Stamp

- c) Please note that should you have offered a discounted price(s), Transnet will only consider such price discount(s) in the final evaluation stage if offered on an unconditional basis.

Respondent's Signature

Date & Company Stamp

SECTION 4

CERTIFICATE OF ACQUAINTANCE WITH RFQ DOCUMENTS

By signing this certificate the Respondent is deemed to acknowledge that he/she has made himself/herself thoroughly familiar with, and agrees with all the conditions governing this RFQ. This includes those terms and conditions contained in any printed form stated to form part hereof, including but not limited to the documents stated below. As such, Transnet will recognise no claim for relief based on an allegation that the Respondent overlooked any such condition or failed properly to take it into account in calculating tendered prices or any other purpose:

1. Transnet’s General Bid Conditions*
2. Standard RFQ Terms and Conditions for the supply of Goods or Services to Transnet
3. Transnet’s Supplier Integrity Pact*
4. Non-disclosure Agreement*
5. Vendor Application Form* and all supporting documents (first time vendors only). Alternatively, for all existing vendors, please complete the table below under the heading “Existing vendors”.
Respondents are to note that the documents marked with a “*” are available on request or at the Transnet website (www.transnet.net). Please click on “Business with Us”, proceed to the tab “Tenders” and then click on “Standard Bid Documents”.

Existing vendors: existing vendors are required to confirm whether all the information (e.g. company address, contact details, banking details, etc.) relating to the existing vendor number is still correct at the time of submission of this bid or update their information in the table below:

Transnet Operating Division [e.g. TFR, TE, etc.]	Vendor Number	Information still current [tick if applicable]	Information change [indicate detail of change/s & attach appropriate proof]

Should the Bidder find any terms or conditions stipulated in any of the relevant documents quoted in the RFQ unacceptable, it should indicate which conditions are unacceptable and offer alternatives by written submission on its company letterhead, attached to its submitted Bid. Any such submission shall be subject to review by Transnet’s Legal Counsel who shall determine whether the proposed alternative(s) are acceptable or otherwise, as the case may be. A material deviation from the Standard terms or conditions could result in disqualification.

Bidders accept that an obligation rests on them to clarify any uncertainties regarding any bid to which they intend to respond, before submitting the bid. The Bidder agrees that he/she will have no claim based on an allegation that any aspect of this RFQ was unclear but in respect of which he/she failed to obtain clarity.

The bidder understands that his/her Bid will be disqualified if this Certificate of Acquaintance with RFQ documents included in the RFQ as a returnable document, is found not to be true and complete in every respect.

 Respondent’s Signature

 Date & Company Stamp

SIGNED at _____ on this ____ day of _____ 20__

SIGNATURE OF WITNESSES

ADDRESS OF WITNESSES

1 _____

Name _____

2 _____

Name _____

SIGNATURE OF RESPONDENT'S AUTHORISED REPRESENTATIVE: _____

NAME: _____

DESIGNATION: _____

SECTION 5

RFQ DECLARATION AND BREACH OF LAW FORM

NAME OF ENTITY: _____

We _____ do hereby certify that:

1. Transnet has supplied and we have received appropriate responses to any/all questions [as applicable] which were submitted by ourselves for RFQ Clarification purposes;
2. we have received all information we deemed necessary for the completion of this Request for Quotation [**RFQ**];
3. We have been provided with sufficient access to the existing Transnet facilities/sites and any and all relevant information relevant to the Supply of the Goods as well as Transnet information and Employees, and has had sufficient time in which to conduct and perform a thorough due diligence of Transnet's operations and business requirements and assets used by Transnet. Transnet will therefore not consider or permit any pre- or post-contract verification or any related adjustment to pricing, service levels or any other provisions/conditions based on any incorrect assumptions made by the Respondent in arriving at his Bid Price.
4. at no stage have we received additional information relating to the subject matter of this RFQ from Transnet sources, other than information formally received from the designated Transnet contact(s) as nominated in the RFQ documents;
5. we are satisfied, insofar as our entity is concerned, that the processes and procedures adopted by Transnet in issuing this RFQ and the requirements requested from Bidders in responding to this RFQ have been conducted in a fair and transparent manner; and
6. furthermore, we declare that a family, business and/or social relationship **exists / does not exist** [delete as applicable] between an owner / member / director / partner / shareholder of our entity and an employee or board member of the Transnet Group including any person who may be involved in the evaluation and/or adjudication of this Bid.
7. In addition, we declare that an owner / member / director / partner / shareholder of our entity **is / is not** [delete as applicable] an employee or board member of the Transnet Group.
8. If such a relationship as indicated in paragraph 6 and/or 7 exists, the Respondent is to complete the following section:

FULL NAME OF OWNER/MEMBER/DIRECTOR/
PARTNER/SHAREHOLDER:

ADDRESS:

Indicate nature of relationship with Transnet:

[Failure to furnish complete and accurate information in this regard will lead to the disqualification of a response and may preclude a Respondent from doing future business with Transnet]

9. We declare, to the extent that we are aware or become aware of any relationship between ourselves and Transnet [other than any existing and appropriate business relationship with Transnet] which could unfairly advantage our entity in the forthcoming adjudication process, we shall notify Transnet immediately in writing of such circumstances.

BREACH OF LAW

10. We further hereby certify that I/we **have/have not been** [delete as applicable] found guilty during the preceding 5 [five] years of a serious breach of law, including but not limited to a breach of the Competition Act, 89 of 1998, by a court of law, tribunal or other administrative body. The type of breach that the Respondent is required to disclose excludes relatively minor offences or misdemeanours, e.g. traffic offences. This includes the imposition of an administrative fine or penalty.

Where found guilty of such a serious breach, please disclose:

NATURE OF BREACH:

DATE OF BREACH: _____

Furthermore, I/we acknowledge that Transnet SOC Ltd reserves the right to exclude any Respondent from the bidding process, should that person or entity have been found guilty of a serious breach of law, tribunal or regulatory obligation.

SIGNED at _____ on this ____ day of _____ 20__

For and on behalf of _____ duly authorised hereto	AS WITNESS:
Name:	Name:
Position:	Position:
Signature:	Signature:
Date:	Registration No of Company/CC _____
Place:	Registration Name of Company/CC _____

SECTION 6

B-BBEE PREFERENCE POINTS CLAIM FORM

This preference form must form part of all bids invited. It contains general information and serves as a claim for preference points for Broad-Based Black Economic Empowerment [B-BBEE] Status Level of Contribution.

NB: BEFORE COMPLETING THIS FORM, BIDDERS MUST STUDY THE GENERAL CONDITIONS, DEFINITIONS AND DIRECTIVES APPLICABLE IN RESPECT OF B-BBEE, AS PRESCRIBED IN THE PREFERENTIAL PROCUREMENT REGULATIONS, 2011.

1. GENERAL CONDITIONS

1.1 The following preference point systems are applicable to all bids:

- the 80/20 system for requirements with a Rand value of up to R1 000 000 (all applicable taxes included); and

1.2 The value of this bid is estimated to **not exceed** R1 000 000 (all applicable taxes included) and therefore the 80/20 preference point system shall be applicable.

1.3 Preference points for this bid shall be awarded for:

- (a) Price; and
- (b) B-BBEE Status Level of Contribution.

1.4 The maximum points for this bid are allocated as follows:

	POINTS
PRICE	80
B-BBEE STATUS LEVEL OF CONTRIBUTION	20
Total points for Price and B-BBEE must not exceed	100

1.5 **Failure on the part of a bidder to submit** a B-BBEE Verification Certificate from a Verification Agency accredited by the South African Accreditation System [SANAS], or a Registered Auditor approved by the Independent Regulatory Board of Auditors [IRBA] or a sworn affidavit confirming annual turnover and level of black ownership in case of all EMEs and QSEs with 51% black ownership or more together with the bid, will be interpreted to mean that preference points for B-BBEE status level of contribution **are not claimed**.

1.6 The purchaser reserves the right to require of a bidder, either before a bid is adjudicated or at any time subsequently, to substantiate any claim in regard to preferences, in any manner required by the purchaser.

2. DEFINITIONS

- (a) **"all applicable taxes"** includes value-added tax, pay as you earn, income tax, unemployment insurance fund contributions and skills development levies;
- (b) **"B-BBEE"** means broad-based black economic empowerment as defined in section 1 of the Broad-Based Black Economic Empowerment Act;
- (c) **"B-BBEE status level of contributor"** means the B-BBEE status received by a measured entity based on its overall performance using the relevant scorecard contained in the Codes of Good Practice on Black Economic Empowerment, issued in terms of section 9(1) of the Broad-Based Black Economic Empowerment Act;
- (d) **"bid"** means a written offer in a prescribed or stipulated form in response to an invitation by an organ of state for the provision of services, works or goods, through price quotations, advertised

competitive bidding processes or proposals;

- (e) **"Broad-Based Black Economic Empowerment Act"** means the Broad-Based Black Economic Empowerment Act, 2003 (Act No. 53 of 2003);
- (f) **"CIPC"** means the Companies and Intellectual Property Commission, formerly known as CIPRO, the Companies and Intellectual Property Registration Office.
- (g) **"comparative price"** means the price after the factors of a non-firm price and all unconditional discounts that can be utilized have been taken into consideration;
- (h) **"consortium or joint venture"** means an association of persons for the purpose of combining their expertise, property, capital, efforts, skill and knowledge in an activity for the execution of a contract;
- (i) **"contract"** means the agreement that results from the acceptance of a bid by an organ of state;
- (j) **"EME"** means an Exempted Micro Enterprise as defines by Codes of Good Practice under section 9 (1) of the Broad-Based Black Economic Empowerment Act, 2003 (Act No. 53 of 2003);
- (k) **"firm price"** means the price that is only subject to adjustments in accordance with the actual increase or decrease resulting from the change, imposition, or abolition of customs or excise duty and any other duty, levy, or tax, which, in terms of the law or regulation, is binding on the contractor and demonstrably has an influence on the price of any supplies, or the rendering costs of any service, for the execution of the contract;
- (l) **"functionality"** means the measurement according to predetermined norms, as set out in the bid documents, of a service or commodity that is designed to be practical and useful, working or operating, taking into account, among other factors, the quality, reliability, viability and durability of a service and the technical capacity and ability of a bidder;
- (m) **"non-firm prices"** means all prices other than "firm" prices;
- (n) **"person"** includes a juristic person;
- (o) **"QSE"** means a Qualifying Small Enterprise as defines by Codes of Good Practice under section 9 (1) of the Broad-Based Black Economic Empowerment Act, 2003 (Act No. 53 of 2003);
- (p) **"rand value"** means the total estimated value of a contract in South African currency, calculated at the time of bid invitations, and includes all applicable taxes and excise duties;
- (q) **"sub-contract"** means the primary contractor's assigning, leasing, making out work to, or employing, another person to support such primary contractor in the execution of part of a project in terms of the contract;
- (r) **"total revenue"** bears the same meaning assigned to this expression in the Codes of Good Practice on Black Economic Empowerment, issued in terms of section 9(1) of the Broad-Based Black Economic Empowerment Act and promulgated in the *Government Gazette* on 9 February 2007;
- (s) **"trust"** means the arrangement through which the property of one person is made over or bequeathed to a trustee to administer such property for the benefit of another person; and
- (t) **"trustee"** means any person, including the founder of a trust, to whom property is bequeathed in order for such property to be administered for the benefit of another person.

3. ADJUDICATION USING A POINT SYSTEM

- 3.1 The bidder obtaining the highest number of total points will be awarded the contract.
- 3.2 Preference points shall be calculated after prices have been brought to a comparative basis taking into account all factors of non-firm prices and all unconditional discounts.
- 3.3 Points scored must be rounded off to the nearest 2 decimal places.

- 3.4 In the event that two or more bids have scored equal total points, the successful bid must be the one scoring the highest number of preference points for B-BBEE.
- 3.5 However, when functionality is part of the evaluation process and two or more bids have scored equal points including equal preference points for B-BBEE, the successful bid must be the one scoring the highest score for functionality.
- 3.6 Should two or more bids be equal in all respects, the award shall be decided by the drawing of lots.

4. POINTS AWARDED FOR PRICE

4.1 THE 80/20 PREFERENCE POINT SYSTEMS

A maximum of 80 points is allocated for price on the following basis:

$$P_s = 80 \left(1 - \frac{P_t - P_{\min}}{P_{\min}} \right)$$

Where

- P_s = Points scored for comparative price of bid under consideration
- P_t = Comparative price of bid under consideration
- P_{\min} = Comparative price of lowest acceptable bid

5. POINTS AWARDED FOR B-BBEE STATUS LEVEL OF CONTRIBUTION

- 5.1 In terms of Regulation 5 (2) and 6 (2) of the Preferential Procurement Regulations, preference points must be awarded to a bidder for attaining the B-BBEE status level of contribution in accordance with the table below:

B-BBEE Status Level of Contributor	Number of points (80/20 system)
1	20
2	18
3	16
4	12
5	8
6	6
7	4
8	2
Non-compliant contributor	0

- 5.2 A bidder who qualifies as an EME in terms of the B-BBEE Act **must submit a sworn affidavit confirming Annual Total Revenue and Level of Black Ownership**. Furthermore EMEs may also obtain a sworn affidavit from CIPC (formerly CIPRO) Self Service Terminals when registering a business or filing annual returns. In these instances Transnet would require proof of turnover as well as proof of ownership. Sworn affidavits must substantially comply with the format that can be obtained on the DTI’s website at www.dti.gov.za/economic_empowerment/bee_codes.jsp.
- 5.3 **QSEs that are at least 51% Black owned or higher are only required to obtain a sworn affidavit** on an annual basis confirming that the entity has an Annual Total Revenue of R50 million or less and the entity’s Level of Black ownership.
- 5.4 A Bidder other than EME or a QSE that is at least 51% Black owned must submit their original and valid B-BBEE status level verification certificate or a certified copy thereof, substantiating their B-

BBEE rating issued by a Registered Auditor approved by IRBA or a Verification Agency accredited by SANAS.

- 5.5 A trust, consortium or joint venture, will qualify for points for their B-BBEE status level as a legal entity, provided that the entity submits their B-BBEE status level certificate.
- 5.6 A trust, consortium or joint venture will qualify for points for their B-BBEE status level as an unincorporated entity, provided that the entity submits their consolidated B-BBEE scorecard as if they were a group structure and that such a consolidated B-BBEE scorecard is prepared for every separate bid.
- 5.7 Tertiary Institutions and Public Entities will be required to submit their B-BBEE status level certificates in terms of the specialized scorecard contained in the B-BBEE Codes of Good Practice.
- 5.8 A person will not be awarded points for B-BBEE status level if it is indicated in the bid documents that such a bidder intends sub-contracting more than 25% of the value of the contract to any other enterprise that does not qualify for at least the points that such a bidder qualifies for, unless the intended sub-contractor is an EME that has the capability and ability to execute the sub-contract.
- 5.9 A person awarded a contract may not sub-contract more than 25% of the value of the contract to any other enterprise that does not have an equal or higher B-BBEE status level than the person concerned, unless the contract is sub-contracted to an EME that has the capability and ability to execute the sub-contract.
- 5.10 Bidders are to note that the rules pertaining to B-BBEE verification and other B-BBEE requirements may be changed from time to time by regulatory bodies such as National Treasury or the DTI. It is the Bidder's responsibility to ensure that his/her bid complies fully with all B-BBEE requirements at the time of the submission of the bid.

6. BID DECLARATION

6.1 Bidders who claim points in respect of B-BBEE Status Level of Contribution must complete the following:

7. B-BBEE STATUS LEVEL OF CONTRIBUTION CLAIMED IN TERMS OF PARAGRAPHS 1.4 AND 5.1

7.1 B-BBEE Status Level of Contribution: . =(maximum of 10 or 20 points)

(Points claimed in respect of paragraph 7.1 must be in accordance with the table reflected in paragraph 5.1 and must be substantiated by means of a B-BBEE certificate issued by a Verification Agency accredited by SANAS or a Registered Auditor approved by IRBA or a sworn affidavit.

8. SUB-CONTRACTING

8.1 Will any portion of the contract be sub-contracted?

(Tick applicable box)

YES		NO	
-----	--	----	--

8.1.1 If yes, indicate:

- i) What percentage of the contract will be subcontracted.....%
- ii) The name of the sub-contractor.....
- iii) The B-BBEE status level of the sub-contractor.....
- iv) Whether the sub-contractor is an EME.

(Tick applicable box)

YES		NO	
-----	--	----	--

9. DECLARATION WITH REGARD TO COMPANY/FIRM

9.1 Name of company/firm:.....

9.2 VAT registration number:.....

9.3 Company registration number:.....

9.4 **TYPE OF COMPANY/ FIRM**

- Partnership/Joint Venture / Consortium
- One person business/sole propriety
- Close corporation
- Company
- (Pty) Limited

[TICK APPLICABLE BOX]

9.5 **DESCRIBE PRINCIPAL BUSINESS ACTIVITIES**

.....
.....

9.6 **COMPANY CLASSIFICATION**

- Manufacturer
- Supplier
- Professional service provider
- Other service providers, e.g. transporter, etc.

[TICK APPLICABLE BOX]

9.7 Total number of years the company/firm has been in business:.....

9.8 I/we, the undersigned, who is / are duly authorised to do so on behalf of the company/firm, certify that the points claimed, based on the B-BBE status level of contribution indicated in paragraph 7 of the foregoing certificate, qualifies the company/ firm for the preference(s) shown and I / we acknowledge that:

- i) The information furnished is true and correct;
- ii) The preference points claimed are in accordance with the General Conditions as indicated in paragraph 1 of this form;
- iii) In the event of a contract being awarded as a result of points claimed as shown in paragraph 7, the contractor may be required to furnish documentary proof to the satisfaction of the purchaser that the claims are correct;
- iv) If the B-BBEE status level of contribution has been claimed or obtained on a fraudulent basis or any of the conditions of contract have not been fulfilled, the purchaser may, in addition to any other remedy it may have –

- (a) disqualify the person from the bidding process;
- (b) recover costs, losses or damages it has incurred or suffered as a result of that person's conduct;
- (c) cancel the contract and claim any damages which it has suffered as a result of having to make less favourable arrangements due to such cancellation;
- (d) restrict the bidder or contractor, its shareholders and directors, or only the shareholders and directors who acted on a fraudulent basis, from obtaining business from any organ of state for a period not exceeding 10 years, after the *audi alteram partem* (hear the other side) rule has been applied; and
- (e) forward the matter for criminal prosecution.

WITNESSES

1.

2.

.....
SIGNATURE(S) OF BIDDERS(S)

DATE:

ADDRESS

.....

STANDARD RFQ TERMS AND CONDITIONS FOR THE SUPPLY OF GOODS OR SERVICES TO TRANSNET

A Supplier/Service Provider shall be obliged to adhere to the Standard Terms and Conditions for the Supply of Goods and Services to Transnet as expressed hereunder. Should the Respondent find any condition(s) unacceptable, it should indicate which condition(s) is/are unacceptable and offer an alternative(s). A Quotation submitted by a Respondent will be subjected to review and acceptance or rejection of its proposed contractual terms and conditions by Transnet's Legal Counsel, prior to consideration for an award of business. A material deviation from the Standard Terms and Conditions could result in disqualification of a Quotation.

1 SOLE AGREEMENT

Unless otherwise agreed in writing, these terms [**Terms** and each **Term**] and Transnet's purchase order(s) [**Order** or **Orders**] represent the only conditions upon which Transnet SOC Ltd [**Transnet**] procures goods [**the Goods**] or services [**the Services**] specified in the Order from the person to whom the Order is addressed [**the Supplier/Service Provider**]. Transnet does not accept any other conditions which the Supplier/Service Provider may specify, unless otherwise agreed to by Transnet in writing. In the event of any inconsistency between these Terms and any Order, these Terms shall take precedence.

2 CONFORMITY WITH ORDER

An Order shall only be valid if it is reduced to writing and issued by a duly delegated official. Goods/Services shall conform strictly with the Order. The Supplier/Service Provider shall not vary the quantities specified and/or the specification, if any, stipulated in the Order, without the prior written consent of Transnet. The Supplier/Service Provider warrants that the Goods/Services shall be fit for their purpose and of satisfactory quality.

3 DELIVERY AND TITLE

- 3.1 The delivery dates and addresses are those in the Order. Time shall be of the essence in respect of the Supplier's/Service Provider's obligations under the Order.
- 3.2 The Supplier/Service Provider will not be excused for delay in delivery or performance except due to circumstances outside its control and then only subject to the Supplier/Service Provider having notified Transnet in writing on becoming aware of such circumstances. Transnet may terminate an Order, in whole or in part, without incurring any liability to the Supplier/Service Provider if such a delay becomes, in Transnet's absolute opinion, significant.
- 3.3 Risk of loss or damage to Goods shall pass to Transnet on delivery, and title shall pass to Transnet when payment to the Supplier for the Goods has been effected.
- 3.4 If on delivery, the Goods/Services do not conform to the Order, Transnet may reject the Goods/Services and the Supplier/Service Provider shall promptly rectify any defects or in Transnet's opinion, supply appropriate replacement Goods/Services at the Supplier's/Service Provider's expense within the specified delivery times, without any liability due by Transnet. Goods shall be subject to such testing and/or inspection as Transnet may consider necessary.

4 PRICE AND PAYMENT

- 4.1 Prices specified in an Order cannot be increased. Payment for the Goods/Services shall be made by Transnet against an original undisputed invoice(s) [a Tax Invoice], supporting documentation and month-end statement from the Supplier/Service Provider. Tax Invoices plus supporting documentation shall be posted to the address shown in the Order.
- 4.2 Payment of the Supplier's/Service Provider's valid Tax Invoice(s) will be made by Transnet in the South African currency and on the terms stated in the Order, the standard payment terms being 30 [thirty] days from date of receipt by Transnet of a month-end statement, unless otherwise agreed to in writing. Transnet shall arrange for payment of such Tax Invoices and any pre-authorised additional expenses incurred, provided that the authorised expenses are supported by acceptable documentary proof of expenditure incurred [where this is available]. Any amounts due in terms of these Terms shall be paid to the Supplier/Service Provider, taking into account any deduction or set-off and bank charges.

5 PROPRIETARY RIGHTS LIABILITY

If any allegations should be made or any claim asserted against Transnet that ownership of, or any act or omission by Transnet in relation to Goods/Services or any written material provided to Transnet relating to any Goods/Services or pursuant to an Order being a violation or infringement of any third party's contractual, industrial, commercial or intellectual property rights including but not limited to any patent, registered design, design right, trade mark, copyright or service mark on any application thereof, the Supplier/Service Provider hereby indemnifies Transnet against and hold it harmless from any and all losses, liabilities, costs, claims, damages and expenses [including any legal fees] arising directly or indirectly from such allegation or claim provided that this indemnity shall not apply where the allegation or claim arises solely as a result of the Supplier/Service Provider following a design or process originated and furnished by Transnet. The Supplier/Service Provider shall either

- a) procure for Transnet the right to continue using the infringing Goods; or
- b) modify or replace the Goods/Services so that they become non-infringing,

provided that in both cases the Goods/Services shall continue to meet Transnet's requirements and any specifications stipulated in the Order. Should neither option be possible, the Supplier/Service Provider may remove, with Transnet's prior written consent, such Goods/Services and will pay to Transnet a sum equivalent to the purchase price. If Transnet refuses to give such consent, the Supplier/Service Provider shall have no liability in respect of any continued use of the infringing Goods/Services after Supplier's/Service Provider's prior written request to remove the same.

6 PROPRIETARY INFORMATION

All information which Transnet has divulged or may divulge to the Supplier/Service Provider and any information relating to Transnet's business which may have come into the Supplier's/Service Provider's possession whilst carrying out an Order, and the existence of the Order, shall be treated by the Supplier/Service Provider as confidential information and shall not, without Transnet's prior written consent, be disclosed to any third party, or be used or copied for any purposes other than to perform the Order. This clause does not apply to information which is public knowledge or available from other sources

other than by breach of this Term. Upon request by Transnet, the Supplier/Service Provider shall return all materials issued pursuant to the Order and, pending this, shall protect Transnet's rights in any such materials. Such confidential information shall at all material times be the property of Transnet.

7 DEVELOPMENT WORK IN THE PRODUCTION OF GOODS

If the production or provision of any Goods involves research and/or development which are wholly or partly funded by Transnet, then all intellectual property or other rights as a result thereof shall be the property of Transnet on creation.

8 PUBLICITY

The Supplier/Service Provider shall not name Transnet or use its trademarks, service marks [whether registered or not] or Goods in connection with any publicity without Transnet's prior written consent.

9 AFTER SALES SERVICE

The Supplier shall provide replacement parts necessary to ensure the uninterrupted operation of the Goods supplied for the duration of the warranty period, from delivery of any particular item of the Goods and if requested by Transnet shall make these parts available to a third party maintainer of Transnet's choice at the same price as if the parts had been supplied to Transnet. The Supplier undertakes to provide a maintenance service for Goods, should Transnet so request, on terms to be agreed. If the Order so indicates, the Supplier will provide a warranty service for the Goods at a level to be agreed with Transnet.

10 TERMINATION OF ORDER

10.1 Transnet may cancel an Order in whole or in part at any time upon at least 7 [seven] days' written notice to the Supplier/Service Provider, or when there is a change in control of the Supplier/Service Provider or the Supplier/Service Provider commits any serious breach or any repeated or continued material breach of its obligations under these Terms and/or Order or shall have been guilty of conduct tending to bring itself into disrepute, on written notice to the Supplier/Service Provider when such work on the Order shall stop.

10.2 Transnet shall pay the Supplier/Service Provider a fair and reasonable price for justified work in progress, where such price reflects only those costs not otherwise recoverable by the Supplier/Service Provider, at the time of termination, and the Supplier/Service Provider shall give Transnet full assistance to check the extent of such work in progress. Payment of such price shall be in full and final satisfaction of any claims arising out of such termination and upon such payment the Supplier/Service Provider shall deliver to Transnet all work, including any materials, completed or in progress. The sum payable to the Supplier/Service Provider under this clause will not in any event exceed the total amount that would have been payable to the Supplier/Service Provider had the Order not been terminated.

10.3 In the event of termination the Supplier/Service Provider must submit all claims within 2 [two] months of termination after which time claims will only be met in what Transnet considers exceptional circumstances.

10.4 If the Goods or Services are not provided in accordance with an Order, the Order shall be deemed terminated and the Supplier/Service Provider shall compensate Transnet for any costs incurred in obtaining substitute Goods or any damage caused due to the failure or delay in the delivery.

11 ACCESS

The Supplier/Service Provider shall be liable for the acts, omissions and defaults of its personnel or agents who, for the purposes of the Order, shall be treated as if they are the Supplier's/Service Provider's employees. The Supplier/Service Provider shall ensure that any such personnel or agents, whilst on Transnet's premises, shall comply with Transnet's health and safety, security and system security rules and procedures as and where required.

12 WARRANTY

The Supplier/Service Provider warrants that it is competent to supply the Goods/Services in accordance with these Terms to the reasonable satisfaction of Transnet and that all Goods/Services delivered under the Order: (a) conform and comply in all relevant legislation, standards, directives and orders related to *[inter alia]* the supply, manufacture and use of the Goods in force at the time of delivery, and to any specifications referred to in the Order; (b) will not cause any deterioration in the functionality of any Transnet equipment; and (c) do not infringe any third party rights of any kind. The Supplier/Service Provider hereby indemnifies Transnet against all losses, liabilities, costs, claims, damages, expenses and awards of any kinds incurred or made against Transnet in connection with any breach of this warranty.

13 INSOLVENCY

If the Supplier/Service Provider shall have a receiver, manager, administrator, liquidator or like person appointed over all or any part of its assets or if the Supplier/Service Provider compounds with its creditors or passes a resolution for the winding up or administration of the Supplier/Service Provider, Transnet is at liberty to terminate the Order or Orders forthwith, or at its option, to seek performance by any such appointed person.

14 ASSIGNMENT

The Supplier/Service Provider shall not assign its obligations under an Order without Transnet's prior written consent, which consent shall not be unreasonably withheld or delayed.

15 NOTICES

Notices under these Terms shall be delivered by hand to the relevant addresses of the parties in the Order or may be served by facsimile or by email, in which event notice shall be deemed served on acknowledgement of receipt by the recipient.

16 LAW

Orders shall be governed by and interpreted in accordance with South African law and any disputes arising herein shall be subject to South African arbitration under the rules of the Arbitration Foundation of South Africa, which rules are deemed incorporated by reference in this clause. The reference to arbitration shall not prevent Transnet referring the matter to any South African courts, having jurisdiction, to which the Supplier/Service Provider hereby irrevocably submits but without prejudice to Transnet's right to take proceedings against the Supplier/Service Provider in other jurisdictions and/or obtaining interim relief on an urgent basis from a court of competent jurisdiction pending the decision in other courts or from instituting in any court of competent jurisdiction any proceedings for an interdict or any other injunctive relief. If the Supplier/Service Provider does not have a registered office in the South Africa it will at all times maintain

an agent for service of process in South Africa and shall give Transnet the name and address of such agent as such may be amended, in writing, from time to time.

17 GENERAL

Completion or termination of an Order shall be without prejudice to any Term herein which by its nature would be deemed to continue after completion or termination, including but not limited to clauses 5, 6, 7, 8, 9, 12 and **Error! Reference source not found.**6. Headings are included herein for convenience only. If any Term herein be held illegal or unenforceable, the validity or enforceability of the remaining Terms shall not be affected. No failure or delay by Transnet to enforce any rights under these Terms will operate as a waiver thereof by Transnet. All rights and remedies available to either party under these Terms shall be in addition to, not to the exclusion of, rights otherwise available at law.

18 COUNTERPARTS

These Terms and conditions may be signed in any number of counterparts, all of which taken together shall constitute one and the same instrument. Any party may enter into this agreement by signing any such counterpart.

19 DATABASE OF RESTRICTED SUPPLIERS

- 19.1 All the stipulations on Transnet's blacklisting process as laid down in Transnet's Supply Chain Policy and Procurement Procedures Manual are included herein by way of reference. Below follows a condensed summary of this blacklisting procedure.
- 19.2 Blacklisting is a mechanism used to exclude a company/person from future business with Transnet and other organs of state for a specified period. On completion of the blacklisting process, the blacklisted entity's details will be placed on National Treasury's Database of Restricted Suppliers for the specified period of exclusion.
- 19.3 The decision to blacklist is based on one of the grounds for blacklisting. The standard of proof to commence the blacklisting process is whether a "*prima facie*" (i.e. on the face of it) case has been established.
- 19.4 Depending on the seriousness of the misconduct and the strategic importance of the Goods/Services, in addition to blacklisting a company/person from future business, Transnet may decide to terminate some or all existing contracts with the company/person as well.
- 19.5 A supplier or contractor to Transnet may not subcontract any portion of the contract to a blacklisted company.
- 19.6 Grounds for blacklisting include: If any person/Enterprise which has submitted a Bid, concluded a contract, or, in the capacity of agent or subcontractor, has been associated with such Bid or contract:
 - a) Has, in bad faith, withdrawn such Bid after the advertised closing date and time for the receipt of Bids;
 - b) has, after being notified of the acceptance of his Bid, failed or refused to sign a contract when called upon to do so in terms of any condition forming part of the bid documents;

- c) has carried out any contract resulting from such bid in an unsatisfactory manner or has breached any condition of the contract;
- d) has offered, promised or given a bribe in relation to the obtaining or execution of the contract;
- e) has acted in a fraudulent or improper manner or in bad faith towards Transnet or any Government Department or towards any public body, Enterprise or person;
- f) has made any incorrect statement in a certificate or other communication with regard to the Goods or Services or his B-BBEE status and is unable to prove to the satisfaction of Transnet that:
 - (i) he made the statement in good faith honestly believing it to be correct; and
 - (ii) before making such statement he took all reasonable steps to satisfy himself of its correctness;
- g) caused Transnet damage, or to incur costs in order to meet the contractor's requirements and which could not be recovered from the contractor;
- h) has litigated against Transnet in bad faith.

19.7 Transnet recognizes that trust and good faith are pivotal to its relationship with its suppliers. When a dispute arises between Transnet and its supplier, the parties should use their best endeavours to resolve the dispute in an amicable manner, whenever possible. Litigation in bad faith negates the principles of trust and good faith on which commercial relationships are based. Accordingly, Transnet will not do business with a company that litigates against it in bad faith or is involved in any action that reflects bad faith on its part. Litigation in bad faith includes, but is not limited to the following instances:

- a) Vexatious proceedings. These are frivolous proceedings which have been instituted without proper grounds;
- b) Perjury. Where a supplier commits perjury either in giving evidence or on affidavit;
- c) Scurrilous allegations. Where a supplier makes allegations regarding a senior Transnet employee which are without a proper foundation, scandalous, abusive or defamatory.
- d) Abuse of court process. When a supplier abuses the court process in order to gain a competitive advantage during a bid process.

19.8 Where any person or Enterprise has been found guilty by a court of law, tribunal or other administrative body of a serious breach of any law, during the preceding 5 Years, such person/Enterprise may also be blacklisted. Serious breaches of the law would include but are not limited to corruption, fraud, theft, extortion, or contraventions of the Competition Act 89 of 1998 (e.g. collusive tendering). This process excludes minor convictions such as traffic offences or personal disagreements between parties which have no bearing on the business operations of the person or Enterprise.

- 19.9 Grounds for blacklisting include a company/person recorded as being a company or person prohibited from doing business with the public sector on National Treasury's Register of Tender Defaulters.
- 19.10 Companies associated with the person/s guilty of misconduct (i.e. entities owned, controlled or managed by such persons), any companies subsequently formed by the person(s) guilty of the misconduct and/or an existing company where such person(s) acquires a controlling stake may be considered for blacklisting. The decision to extend the blacklist to associated companies will be at the sole discretion of Transnet.
- 19.11 Any person or enterprise or company against whom a decision to blacklist has been taken, may make representations to the Chief Financial Officer of Transnet SOC Ltd, whose decision shall be final.

Annexure A

Description of Work

The Supply of 600w and 1000w HPS-T FLOODLIGHT as per Specification Below

1.1 Specification

- 1.1.1 To ensure a life expectancy of more than 25 years, the luminaire shall consist of a marine grade aluminium lamp housing and control gear box made from grade EN1706 AC-44300 aluminium alloy and shall comply with BS 1490. The control gear box shall be separate from the lamp housing.
- 1.1.2 The floodlight shall be designed to operate both (600w, 90 000 lumen) and (1000w, 130 000 lumen) tubular HPS lamps and have the following SANS marks:
- *SANS 475 performance mark, certified by an SABS certificate.*
 - *SANS 60598-2-5 safety mark, certified by an SABS test report*
 - *Must have minimum IP 65 rating, certified by an SABS test report.*
- 1.1.3 The lamp housing shall be weatherproof, hail proof, corrosion proof and vandal resistant and be manufactured from marine grade aluminium grade EN1706 AC-44300 aluminium alloy. The front glass covering the lamp compartment shall be heat tempered and impact resistant, held to the lamp housing by stainless steel clamps and sealed by an extruded heat resistant silicon gasket.
- 1.1.4 The reflector system shall be manufactured from 99,98% super-pure anodized aluminium and shall have an asymmetrical narrow beam distribution.
- 1.1.5 Removal of the front glass shall not be necessary for lamp replacements. Lamp replacements shall be facilitated from the side of the lamp housing with a lamp holder housing made from high-pressure die cast grade EN1706 AC-44300 aluminium alloy. It shall be sealed with a one piece silicon gasket and be held in position with two stainless steel screws.
- 1.1.6 The control gear box shall be manufactured from high-pressure die cast marine grade aluminium EN1706 AC-44300 aluminium alloy and must be separate from the lamp housing for thermal reasons. It shall consist of a lid and body that seals to IP65 when closed and fixed to the stirrup bracket. The stirrup bracket shall be manufactured from hot dipped galvanized steel with pre drilled holes for mounting onto the mast.
- 1.1.7 The control gear components in the control gear box shall be mounted on a removable gear tray and shall be suitable for operation with either 600 or 1000W HPS T lamp on a 230V +3%/-10% 50Hz single phase system.
- 1.1.8 All control gear components shall be removable and bear the relevant SABS mark. All screws, bolts and metal parts shall be stainless steel. Mains connections shall be by means of a suitable screw terminal block with wire clamping contact. The lamp holder shall comply with VC 8011, shall be rated to withstand 240°C/5kV. The ignitor shall be of the superposed pulse type and the luminaire shall be power factor corrected to a minimum of 0.9.

1.1.9 The windage area of the floodlight shall not exceed 0.28 m²

1.1.10 The floodlight shall be similar or equal approved as per the above specification by the Transnet engineer prior to closing date of the tender.

1.1.11 The physical size of the reflector system is related to the performance of the floodlight and therefore should be no smaller than the sizes as shown below:

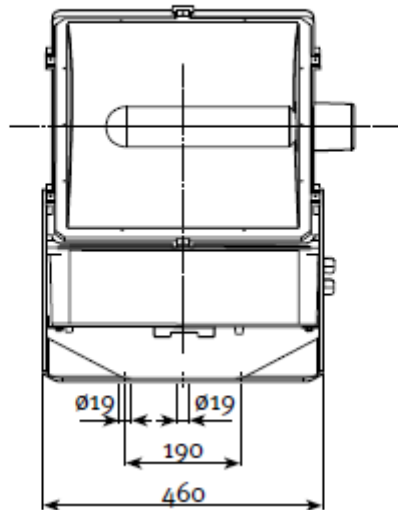
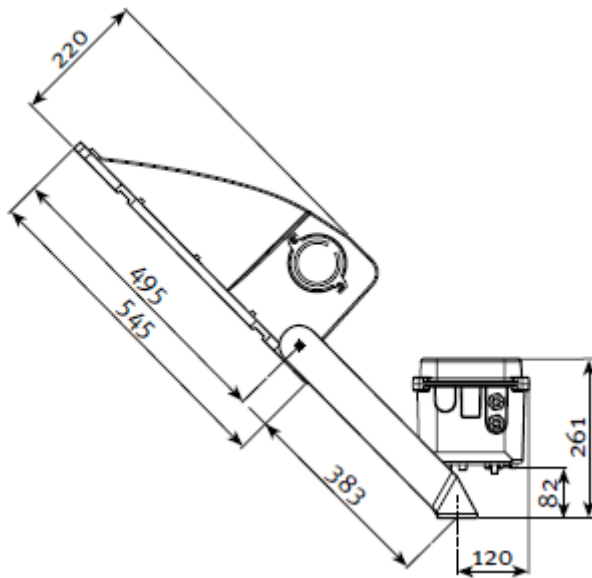

Figure 1

Annexure B

Requirements for 600w and 1000w HPS Floodlight Luminaires

This Schedule shall be completed, signed and returned with the bid documents of which it forms part.

Ref No	Technical Details	Transnet's Requirement	Bidder's Offer
1	Name of manufacturer		
2	Place of manufacture/assembly	Local – S Africa	
3	Manufacturer's identification reference		
4	Place (country) of manufacture (not assembly) of die- cast aluminium housing, control gearbox and lid	Local – S Africa	
5	Specification to which luminaire complies:		
5.1		SANS 60598-2-5 Safety Mark	
5.2		SANS 475 Performance Mark	
6	Type of lamp for luminaire as per design	HPS/T 90 000 lm HPS/T 130 000 lm	
7	Rated wattage of lamp	600w 1000w	
8	<u>Degree of protection to SANS 60529:</u>		
	a) Lamp compartment	minimum IP 65	
	b) Control gear compartment	minimum IP 65	
9	<u>Materials</u>		
9.1	Material of body	Marine grade EN1706 AC-44300 aluminium alloy	
9.2	Material of front protector	Glass	
9.3	Material of gasket	Extruded, silicon	
9.4	Material of reflector	High grade 99,98% super pure deep anodised aluminium	
9.5	Material of lamp holder housing	Marine grade EN1706 AC-44300 aluminium alloy	
9.6	Material of small metal components (external)	stainless steel (minimum grade 304)	
10	Protection of stirrup bracket	hot-dip galvanised to SANS 121	
11	<u>Control Gear</u>		
11.1	Control gear compartment	Thermally Separated from lamp compartment	

Ref No	Technical Details	Transnet's Requirement	Bidder's Offer
11.2	Specification with which ballast complies		
11.3	Make of Ballast		
11.4	Circuit connection (series, parallel)	Series	
11.5	Voltage service range of ballast		
11.7	Ballast factor		
11.8	Specification with which capacitor complies		
11.9	Temperature rating of capacitor		
11.10	Make of ignitor		
11.11	Type of ignitor	superposed pulse type	
11.12	Power factor of luminaire	0,9 lagging (min)	
11.13	Voltage rating of wiring		
12	<u>Lampholder</u>		
12.1	Specification to which lampholder complies	SANS VC 8011	
12.2	Type of lampholder	GES	
12.3	Rated voltage of lampholder	5KV	
12.4	Material of lampholder	Porcelain	
12.5	Rated withstand temperature	240 °C	
13	Gross mass of complete luminaire (Excluding lamp)	600w 28kg max 1000w 30.4 kg max	
14	Beam distribution		
14.1	beam distribution 1000w	Narrow Beam	
14.2	beam distribution - 600w	Wide Beam	
16	Guarantee period on Luminaire	5 Years	
17	Guarantee period on control gear	18 Months	

1.