

MAY 2011 – OL11051

**SCHEDULE OF REQUIREMENTS
ERECTION OF OPTIC FIBRE CABLE ON TRACTION MASTS**

1. SCOPE

This schedule covers the requirements of Transnet for the erection of optic fibre cable on the traction mast poles, and other related services. These services will be required along the Ore Line at four wayside or condition monitoring sites.

2. COMPLIANCE

2.1. Tenders must comply with all the specifications and requirements as indicated in this and attached documents. Any deviation from these specification must be indicated in the tenderer`s submission document.

2.2. The tenderers must preferably have previous experience of erecting optic fibre cable on overhead mast poles along railway lines.

2.3. Transnet will reserve the right to obtain references on any of the tenderers before adjudication of the contract.

2.4. The following attached specifications will also comply in this project and must be considered in all quotation:

2.4.1. SPC-00575 Specification for the Erection of Self-Supporting Optical Fibre Cable on Traction Masts

2.4.2. SPC-00029 Trenching, Laying and Hauling in of Communication Cables

2.4.3. SPC-01242 Specification for Wooden Telephone Poles

2.4.4. SPC-01279 Specification for the Erection of Wooden Telephone Poles for the Support of Optical Fibre Cables

2.4.5. PRC-00106 Post-Installation Test of Optic Fibre Cable

3. SERVICE CONDITIONS

3.1. The equipment must be suitable to be used, withstand and last in the following conditions with an expected life service of at least 15 years:

3.1.1. Temperatures between -10° and $+45^{\circ}$.

3.1.2. Relative humidity as high as 95%.

3.1.3. Wind speeds of 160 Kph (40m/s).

3.2. All components and parts must be manufactured and installed to ensure reliable operation under these conditions.

4. DESCRIPTION OF THE FOUR WAYSIDE SITES

All kilometer points provided below, are as measured along the railway line from Salkor Saldanha

4.1. **Km 101** - This site is 101 km from Saldanha.

4.2. **Km 195** - This site is 195 km from Saldanha.

4.3. **Km 718** - This site is 718 km from Saldanha.

4.4. **Km 765** - This site is 765 km from Saldanha.

5. DESCRIPTION OF WORK THAT MUST BE PERFORMED

At each of these sites a container will be placed and a transmission service must be provided to these containers. It will be required of the Contractor to install a 24-core optic fibre cable between each container and the closest optic fibre joint. This joint is an existing joint on an optic fibre cable already installed along the line. The length of the cables that must be installed varies from site to site but the details of the installations are available on the provided survey documents (**Annexure A**).

All the work on the four sites must be done according to the provided specifications and the work can be described as follows:

4.1. Splice 12 optic fibres into an existing optic fibre joint. The 12 optic fibres must be spliced onto the last tube, 6 fibres going north and 6 fibres going south.

4.2. Erect the optic fibre cable on the mast poles from the joint to the point where it will take-off to the container (This will not be required at Km 101).

4.3. Provide and install a wooden pole close to the optic fibre take-off point and erect the optic fibre cable from the mast pole to the wooden pole. From this point it will be laid underneath the ground to the container. At Km 718 there is an existing pole that can be used.

4.4. Core drill underneath the railway line and install a 110 mm Nextube.

4.5. Trench from the pole to the entry of the Nextube and then again from the exit of the Nextube to the container.

4.6. Install a 32mm PVC Sub-duct from the top of the wooden pole to the container.

4.7. Install the optic fibre cable in the sub-duct from the top of the wooden pole to the container.

4.8. Terminate all 24 optic fibre cores on an E2000 patch panel in the container.

4.9. Test all optic fibres that were terminated and spliced.

6. BRACKETS AND OTHER INSTALLATION REQUIREMENTS

There is an existing 24-core optic fibre cable installed on the traction mast poles between Saldanha and Sishen. LaserFab brackets were used for the original installation. The optic fibre cables that must be installed as part of this project must be installed on the “**LaserFab Extension Bracket**”. This extension bracket hooks onto the existing LaserFab bracket (see **Annexure B** with pictures and detail on all the LaserFab Brackets). The extension bracket is available from LaserFab.

- 6.1. All the material supplied for Km 101 and Km 195 must comply with coastal requirements but the material for Km 718 and Km 765 can be non-coastal.
- 6.2. The distance that wooden poles must be planted from the traction line is the length of the pole plus 3 meters (12 meter).
- 6.3. Km 718 does have an existing wooden pole that can also be used for the second optic fibre cable.
- 6.4. All wooden poles must be provided with Unistrut from top to bottom. The Unistrut must host the sub-duct with optic fibre cable. The Unistrut must be fastened to the wooden pole.
- 6.5. All “False Terminations” and “Slack Coils” as indicated on the survey sheets must be implemented.
- 6.6. Concrete cable markers for this project must be supplied and installed:
 - 6.6.1. Within 5 meters after the entry point into the ground.
 - 6.6.2. Within 5 meters before the exit point from the ground.
 - 6.6.3. At ever point where the cable changes direction underground.
 - 6.6.4. Every 50 meters or in the middle of a section longer than 50 meters.
- 6.7. All optic fibre splicing must be fusion splicing and must comply with specifications.

7. SUPPLY OF MATERIAL:

- 7.1. Transnet Freight Rail will provide the following material:
 - 7.1.1. Optic fibre cable, 24 core, short span, anti-tracking.
 - 7.1.2. Splice trays with all accessories.
 - 7.1.3. Mid-couplers
 - 7.1.4. Pigtails
 - 7.1.5. Splice protection sleeves
- 7.2. The contractor will have to supply all the other material that may be required to erect, lay and terminate the optic fibre fiber cable. This material will included but is not limited to:
 - 7.2.1. All LaserFab brackets for termination and suspension.

- 7.2.2. The 1-meter stand-off brackets.
 - 7.2.3. The wooden pole brackets.
 - 7.2.4. PLP tangents and dead-ends.
 - 7.2.5. Wooden telephone poles with stays where required.
 - 7.2.6. Unistrat 40 x 40 with clamps.
 - 7.2.7. Sub-duct 32mm PVC.
 - 7.2.8. Nextube 110mm with joints.
 - 7.2.9. Cable markers.
- 7.3. Attached as “**Annexure C**” is a list with quantities of material and labour items. This list is only a guideline to assist tenderers and contractors and is by no means a list with all the material and labour items required.

8. WARRANTY

- 8.1. All material supplied and work performed must carry a warranty of at least 12 months from date of sign-off of the project.

9. RISK AND SAFETY REQUIREMENTS

- 9.1. The successful contractor must comply with Transnet’s risk and safety policy and requirements. Detail will be provided after contract adjudication.
- 9.2. The contractor will also have to comply with the requirements of the OSH Act, Regulation 6 (Supervision of Construction Workers) and Regulation 7 (Risk Assessment).
- 9.3. The contractor will have to attend a half-day induction training session in Saldanha before they can commence with any work.
- 9.4. The E7/1 instructions and requirements will be applicable to the contractor because all the work will be done next the railway line and in close vicinity of the high voltage traction power line.
- 9.5. The contractor will have to provide Transnet with a “Letter of Good Standing” as proof of their registration with the Compensation Commissioner.

10. QUANTITIES AND QUOTATION STRUCTURE:

- 10.1. The quantities and quotation structure as listed below does not cover all the sundry material and smaller items, as may be required by the contractor. These items must be quoted under “Sundry Material”, Item 23.
- 10.2. Any item that is not listed as per the requirements of the Tenderer must be added at the bottom of the quotation schedule, Items 26 to 30.
- 10.3. It is the responsibility of the Tenderer to ensure that all his material, labour and miscellaneous items are covered in the quotation.

Quotation Structure

| Item | Description | Qty | Unit Cost | TOTAL COST (excluding VAT) |
|------|---|-----|-----------|-------------------------------|
| 1 | LaserFab Extension Bracket - Termination | 15 | | |
| 2 | LaserFab Extension Bracket - Suspension | 30 | | |
| 3 | LaserFab 1 meter Stand-off Bracket | 5 | | |
| 4 | Wooden Pole Bracket - Termination | 10 | | |
| 5 | PLP Tangent | 30 | | |
| 6 | PLP Dead End | 25 | | |
| 7 | Wooden Poles – 9 meter | 4 | | |
| 8 | Stay Wires – complete with Anchors | 3 | | |
| 9 | Unistrat – 40 x 40 mm (meters) | 30 | | |
| 10 | PVC Sub-Duct – 32mm (meters) | 300 | | |
| 11 | Nextube Pype – 110mm (6 meter lengths) | 10 | | |
| 12 | Nextube Couplings/Joints | 5 | | |
| 13 | Concrete Cable Markers | 20 | | |
| 14 | Core Drill – Rail Crossings | 4 | | |
| 15 | Trenching – Total requirement (meters) | 160 | | |
| 16 | Fibre Splices – in Down Joint | 48 | | |
| 17 | Splices & Terminate on Pigtail in Patch Panel | 96 | | |
| 18 | Post Installation Tests on Fibre Terminations | 48 | | |
| 19 | Total Installation at Km-101 | 1 | | |
| 20 | Total Installation at Km-195 | 1 | | |
| 21 | Total Installation at Km-718 | 1 | | |
| 22 | Total Installation at Km-765 | 1 | | |
| 23 | Sundry Material (as per Tenderer) | | | |
| 24 | Site Establishment | | | |
| 25 | Travel and Accommodation | | | |
| 26 | | | | |
| 27 | | | | |
| 28 | | | | |
| 29 | | | | |
| 30 | | | | |
| | TOTAL COST (excluding VAT) | | | |
| | Value Added Tax | | | |
| | TOTAL COST (including VAT) | | | |

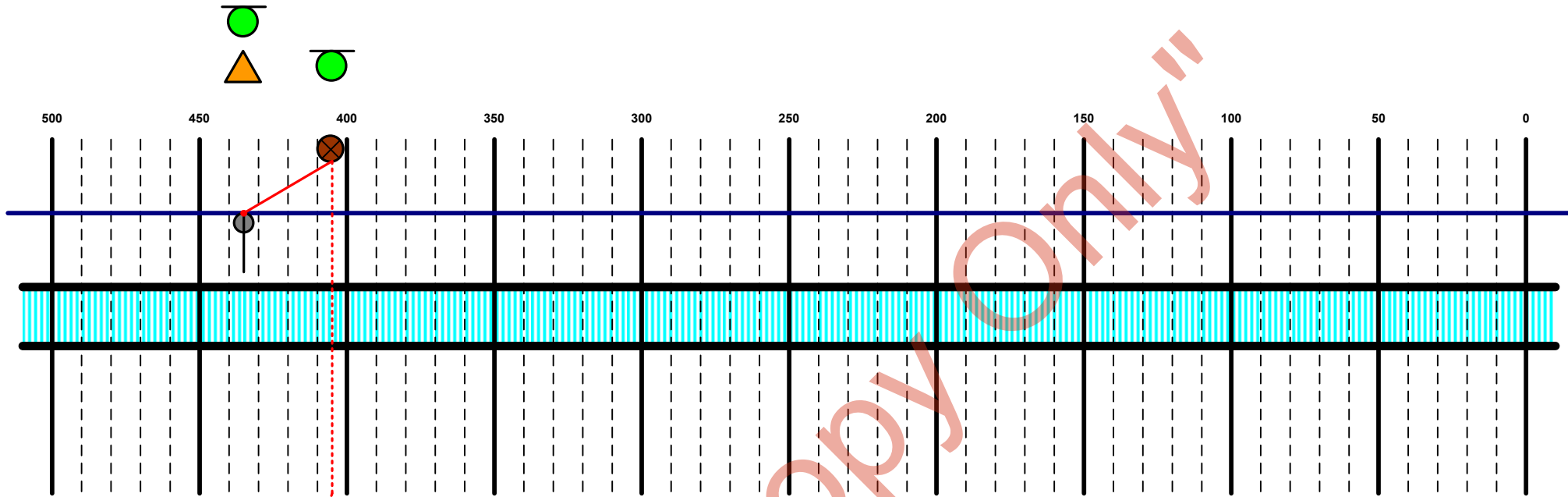

| | | |
|----------------|---|---------------------------------------|
| Mast Number | 101/1 | |
| Bracket Type | Extension for 2 nd Fibre - Termination | Bracket for Wooden Pole - Termination |
| PLP Tangent | 0 | |
| PLP Dead End | 2 | |
| Telephone Pole | 1 | |
| Trenching | 20 meter | |
| Core Drill | 3 meter | |

| | | | | | | | | | |
|-------------|--|------------|--|------------------|--|-------------------|--|------------------------|--|
| Teleph Pole | | False Term | | Slack Coil | | HT on Mast | | Existing Cable Over H | |
| I-Beam Mast | | Joint | | New Cable Over H | | New Cable Under G | | Existing Cable Under G | |

| | | | | |
|---------------------------------|----------|--------------------|--------|----------|
| TITLE | | DESCRIPTION | | |
| WAYSIDE SITE - Km 101 | | Optic Fibre Survey | | |
| FILENAME | | | | DATE |
| ANNEXURE A - SURVEY RESULTS.VSD | | | | 8/4/2011 |
| SCALE | DRAWN BY | REVISED | PAGE | |
| Not to Scale | JVisser | 16/05/2011 | 1 OF 1 | |

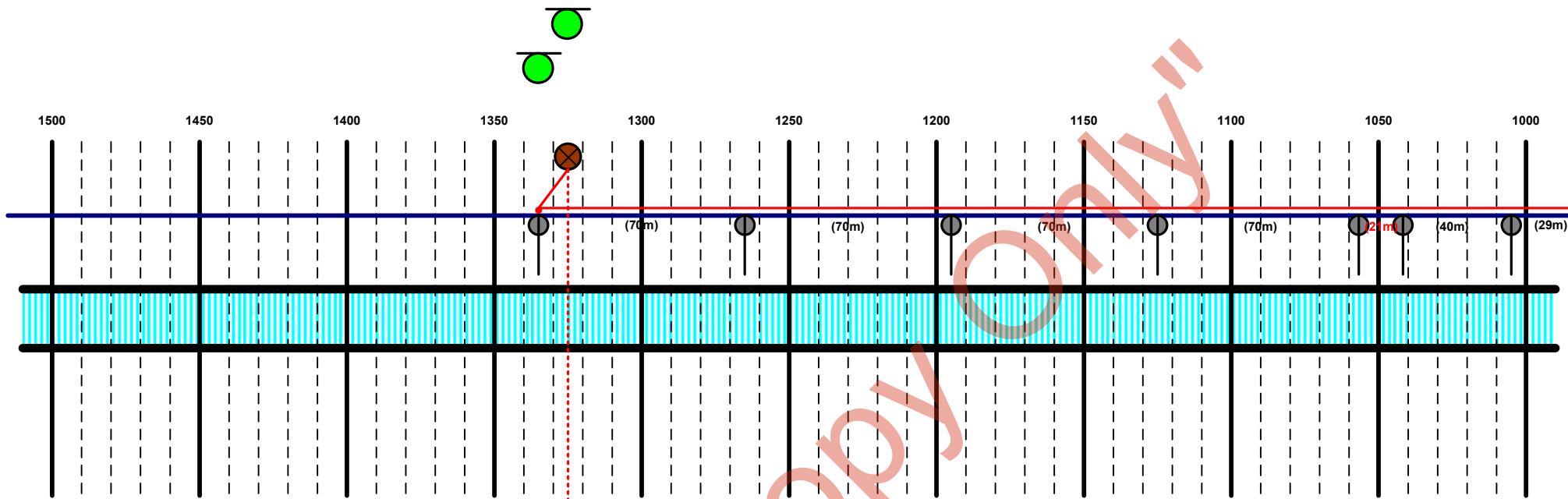

| | | | | | | | | | |
|----------------|---------------------------------------|---|--|--|--|--|--|--|--------|
| Mast Number | | 195/16 | 195/15 | | 195/14 | 195/13 | | 195/12 | 195/11 |
| Bracket Type | Bracket for Wooden Pole - Termination | Extension for 2 nd Fibre - Termination | Extension for 2 nd Fibre - Suspension | | Extension for 2 nd Fibre - Suspension | Extension for 2 nd Fibre Suspension + S/Off | | Extension for 2 nd Fibre - Suspension | |
| PLP Tangent | | 0 | 1 | | 1 | 1 | | 1 | |
| PLP Dead End | | 2 | 0 | | 0 | 0 | | 0 | |
| Telephone Pole | | 1 | | | | | | | |
| Trenching | | 25 meter | | | | | | | |
| Core Drill | | 3 meter | | | | | | | |

| | | | | | | | | | |
|-------------|--|------------|--|------------------|--|-------------------|--|------------------------|--|
| Teleph Pole | | False Term | | Slack Coil | | HT on Mast | | Existing Cable Over H | |
| I-Beam Mast | | Joint | | New Cable Over H | | New Cable Under G | | Existing Cable Under G | |

| | | | |
|---------------------------------|----------|--------------------|----------|
| TITLE | | DESCRIPTION | |
| WAYSIDE SITE - Km 195 | | Optic Fibre Survey | |
| FILENAME | | | DATE |
| ANNEXURE A - SURVEY RESULTS.VSD | | | 8/4/2011 |
| SCALE | DRAWN BY | REVISED | PAGE |
| Not to Scale | JVisser | 16/05/2011 | 1 OF 3 |
| | | | |

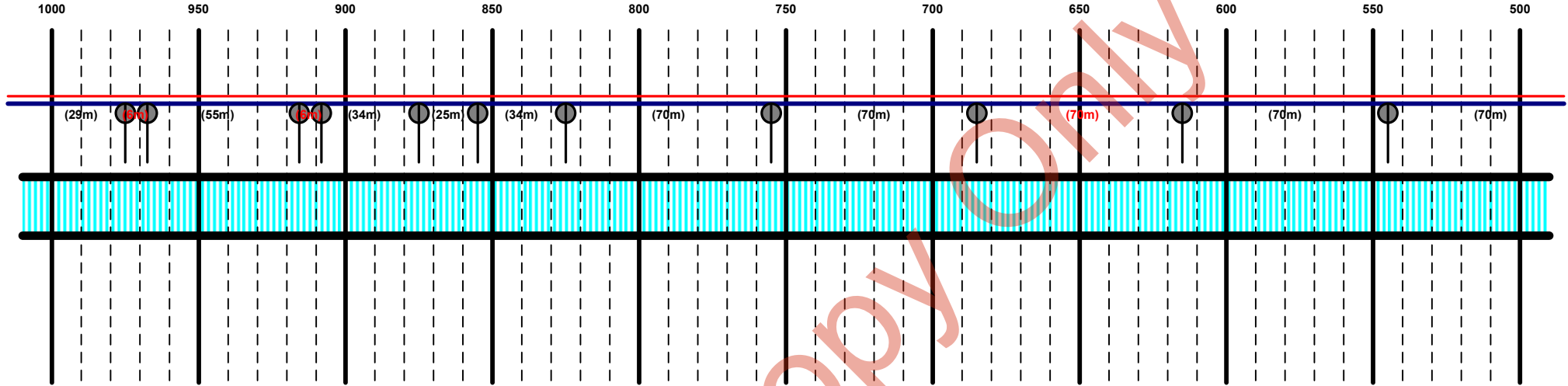

| Mast Number | 195/10 | 195/9 | 195/8 | 195/7 | 195/6 | 195/5 | 195/4 | 195/3 | 195/2 | 195/1 | 194/15 |
|----------------|---|-------|--|-------|--|-------|--|-------|--|-------|--|
| Bracket Type | Extension for 2 nd Fibre - Termination | | Extension for 2 nd Fibre - Suspension | | Extension for 2 nd Fibre - Suspension | | Extension for 2 nd Fibre - Suspension | | Extension for 2 nd Fibre - Suspension | | Extension for 2 nd Fibre - Suspension |
| PLP Tangent | 0 | | 1 | | 1 | | 1 | | 1 | | 1 |
| PLP Dead End | 2 | | 0 | | 0 | | 0 | | 0 | | 0 |
| Telephone Pole | | | | | | | | | | | |
| Trenching | | | | | | | | | | | |
| Core Drill | | | | | | | | | | | |

Teleph Pole

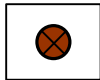

False Term



Slack Coil

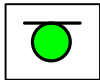

HT on Mast



Existing Cable Over H



I-Beam Mast

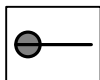

Joint



New Cable Over H

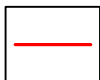

New Cable Under G



Existing Cable Under G



TITLE

WAYSIDE SITE - Km 195

DESCRIPTION

Optic Fibre Survey

FILENAME

ANNEXURE A - SURVEY RESULTS.VSD

DATE

8/4/2011

SCALE

Not to Scale

DRAWN BY

JVisser

REVISED

16/05/2011

PAGE

2 OF 3



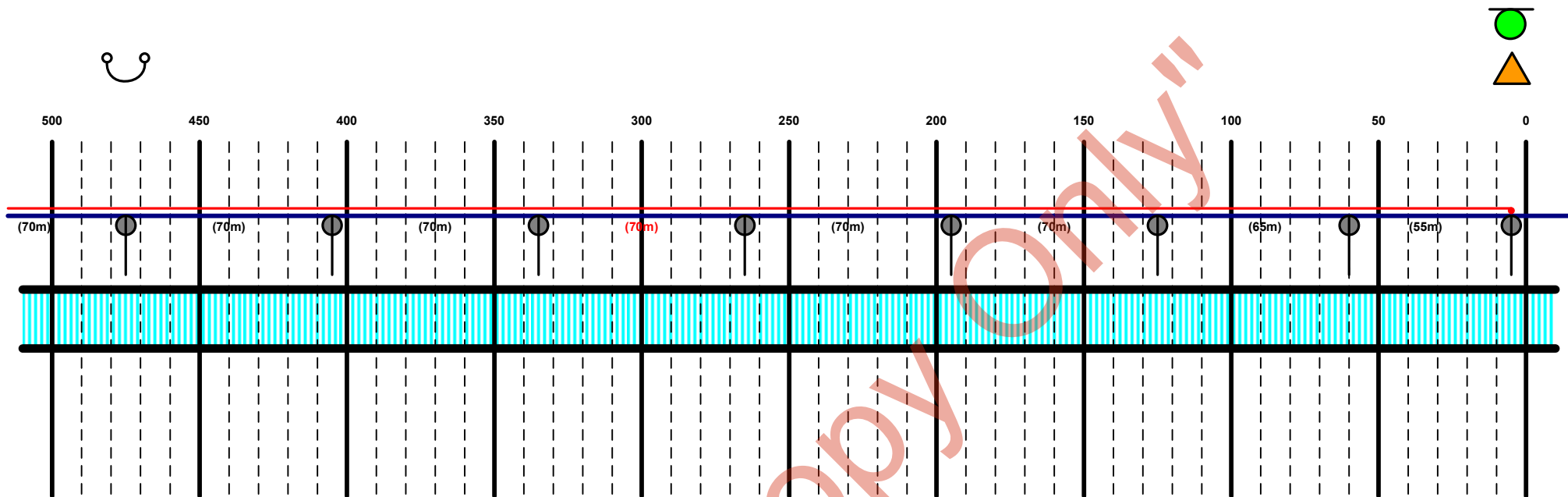

| Mast Number | 194/14 | 194/13 | 194/12 | 194/11 | 194/10 | 194/9 | 194/8 | 194/7 |
|----------------|---|--|--|--|--|--|--|---|
| Bracket Type | Extension for 2 nd Fibre - Termination | Extension for 2 nd Fibre - Suspension | Extension for 2 nd Fibre - Suspension | Extension for 2 nd Fibre - Suspension | Extension for 2 nd Fibre - Suspension | Extension for 2 nd Fibre - Suspension | Extension for 2 nd Fibre - Suspension | Extension for 2 nd Fibre - Termination |
| PLP Tangent | 0 | 1 | 1 | 1 | 1 | 1 | 1 | 0 |
| PLP Dead End | 2 | 0 | 0 | 0 | 0 | 0 | 0 | 1 |
| Telephone Pole | | | | | | | | |
| Trenching | | | | | | | | |
| Core Drill | | | | | | | | |

| | | | | | | | | | |
|-------------|--|------------|--|------------------|--|-------------------|--|------------------------|--|
| Teleph Pole | | False Term | | Slack Coil | | HT on Mast | | Existing Cable Over H | |
| I-Beam Mast | | Joint | | New Cable Over H | | New Cable Under G | | Existing Cable Under G | |

| | | | |
|---|---------------------|-----------------------------------|------------------|
| TITLE WAYSIDE SITE - Km 195 | | DESCRIPTION Optic Fibre Survey | |
| FILENAME ANNEXURE A - SURVEY RESULTS.VSD | | | DATE 8/4/2011 |
| SCALE Not to Scale | DRAWN BY JVisser | REVISED 16/05/2011 | PAGE 3 OF 3 |
| | | | |

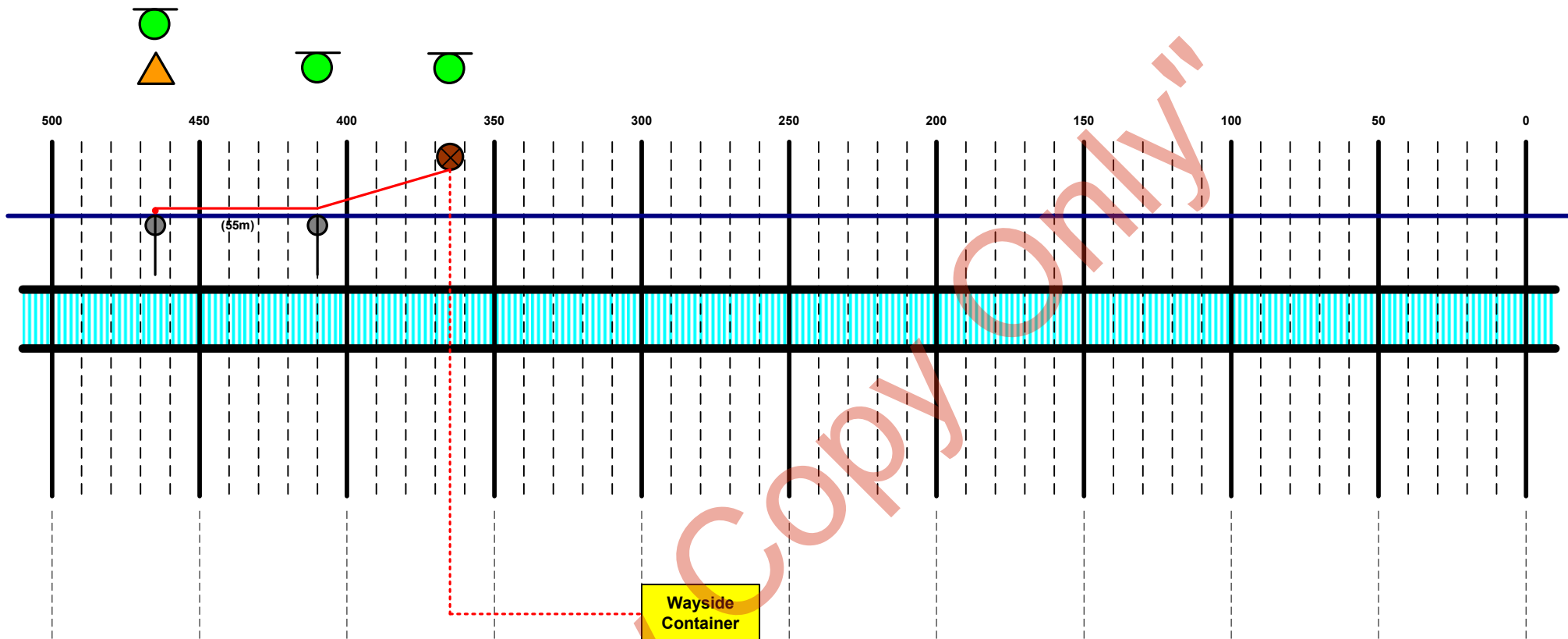

| | | | |
|----------------|---|---|---------------------------------------|
| Mast Number | 718/9 | 718/8 | |
| Bracket Type | Extension for 2 nd Fibre - Termination | Extension for 2 nd Fibre - Termination | Bracket for Wooden Pole - Termination |
| PLP Tangent | 0 | 0 | |
| PLP Dead End | 1 | 2 | 1 |
| Telephone Pole | 0 | 0 | Existing Pole |
| Trenching | | | 90 meter |
| Core Drill | | | 3 meter |

| | | | | | | | | | |
|-------------|--|------------|--|------------------|--|-------------------|--|------------------------|--|
| Teleph Pole | | False Term | | Slack Coil | | HT on Mast | | Existing Cable Over H | |
| I-Beam Mast | | Joint | | New Cable Over H | | New Cable Under G | | Existing Cable Under G | |

| | | | |
|---------------------------------|----------|--------------------|----------|
| TITLE | | DESCRIPTION | |
| WAYSIDE SITE - Km 718 | | Optic Fibre Survey | |
| FILENAME | | | DATE |
| ANNEXURE A - SURVEY RESULTS.VSD | | | 8/4/2011 |
| SCALE | DRAWN BY | REVISED | PAGE |
| Not to Scale | JVisser | 16/05/2011 | 1 OF 1 |
| | | | |

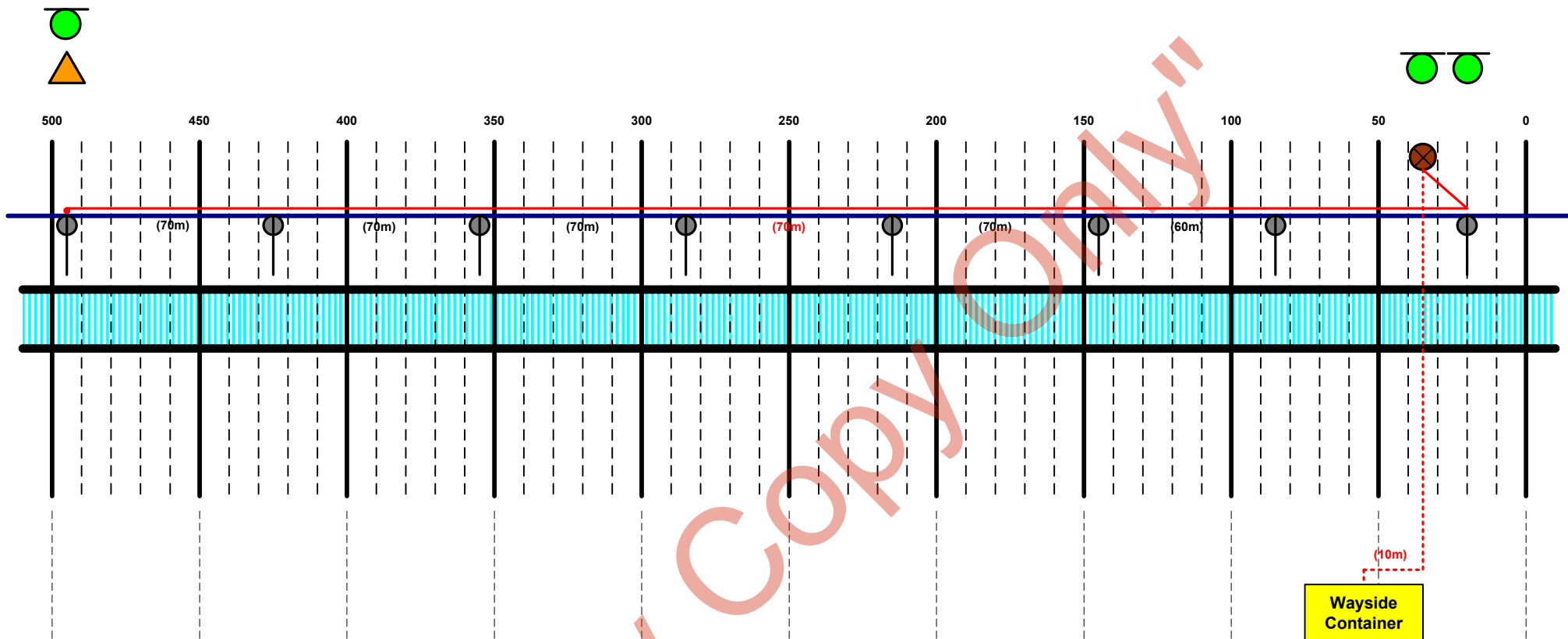

| Mast Number | 766/2 | 766/1 | 766/0 | 765/19 | 765/18 | 765/18 | 765/17 | 765/16 | 765/15 |
|----------------|---|--|--|--|--|--|--|---|---|
| Bracket Type | Extension for 2 nd Fibre - Termination | Extension for 2 nd Fibre - Suspension | Extension for 2 nd Fibre - Suspension | Extension for 2 nd Fibre - Suspension | Extension for 2 nd Fibre - Suspension | Extension for 2 nd Fibre - Suspension | Extension for 2 nd Fibre - Suspension | Extension for 2 nd Fibre Suspension + 1m S/Off | Extension for 2 nd Fibre - Termination |
| PLP Tangent | 0 | 1 | 1 | 1 | 1 | 1 | 1 | 1 | 0 |
| PLP Dead End | 1 | 0 | 0 | 0 | 0 | 0 | 0 | 0 | 3 |
| Telephone Pole | 0 | 0 | 0 | 0 | 0 | 0 | 0 | 0 | 1 |
| Trenching | | | | | | | | | 25 meter |
| Core Drill | | | | | | | | | 3 meter |

| | | | | | | | | | |
|-------------|--|------------|--|------------------|--|-------------------|--|------------------------|--|
| Teleph Pole | | False Term | | Slack Coil | | HT on Mast | | Existing Cable Over H | |
| I-Beam Mast | | Joint | | New Cable Over H | | New Cable Under G | | Existing Cable Under G | |

| | | | |
|---|---------------------|-----------------------------------|------------------|
| TITLE WAYSIDE SITE - Km 765 | | DESCRIPTION Optic Fibre Survey | |
| FILENAME ANNEXURE A - SURVEY RESULTS.VSD | | | DATE 8/4/2011 |
| SCALE Not to Scale | DRAWN BY JVisser | REVISED 16/05/2011 | PAGE 1 OF 1 |
| | | | |

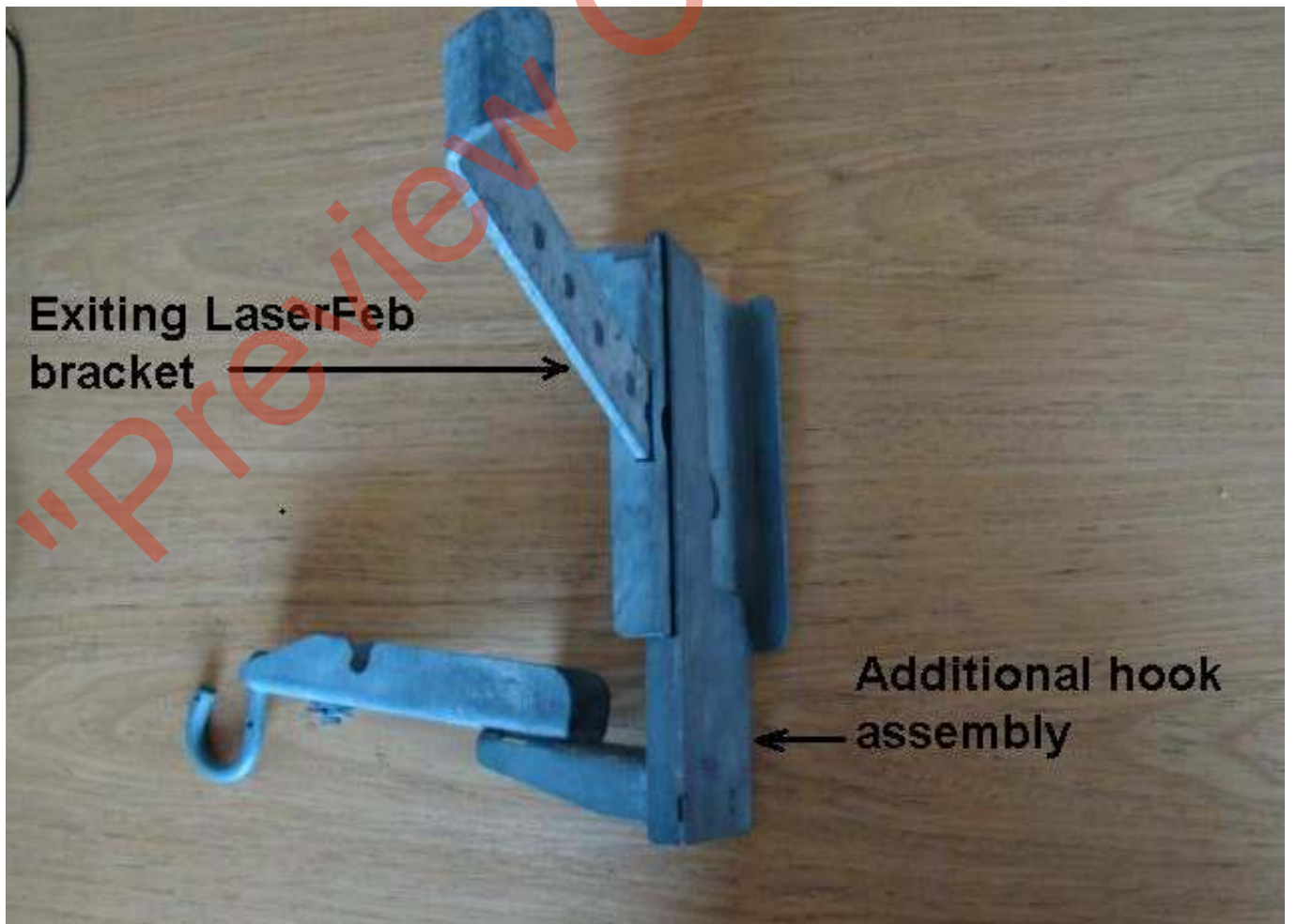



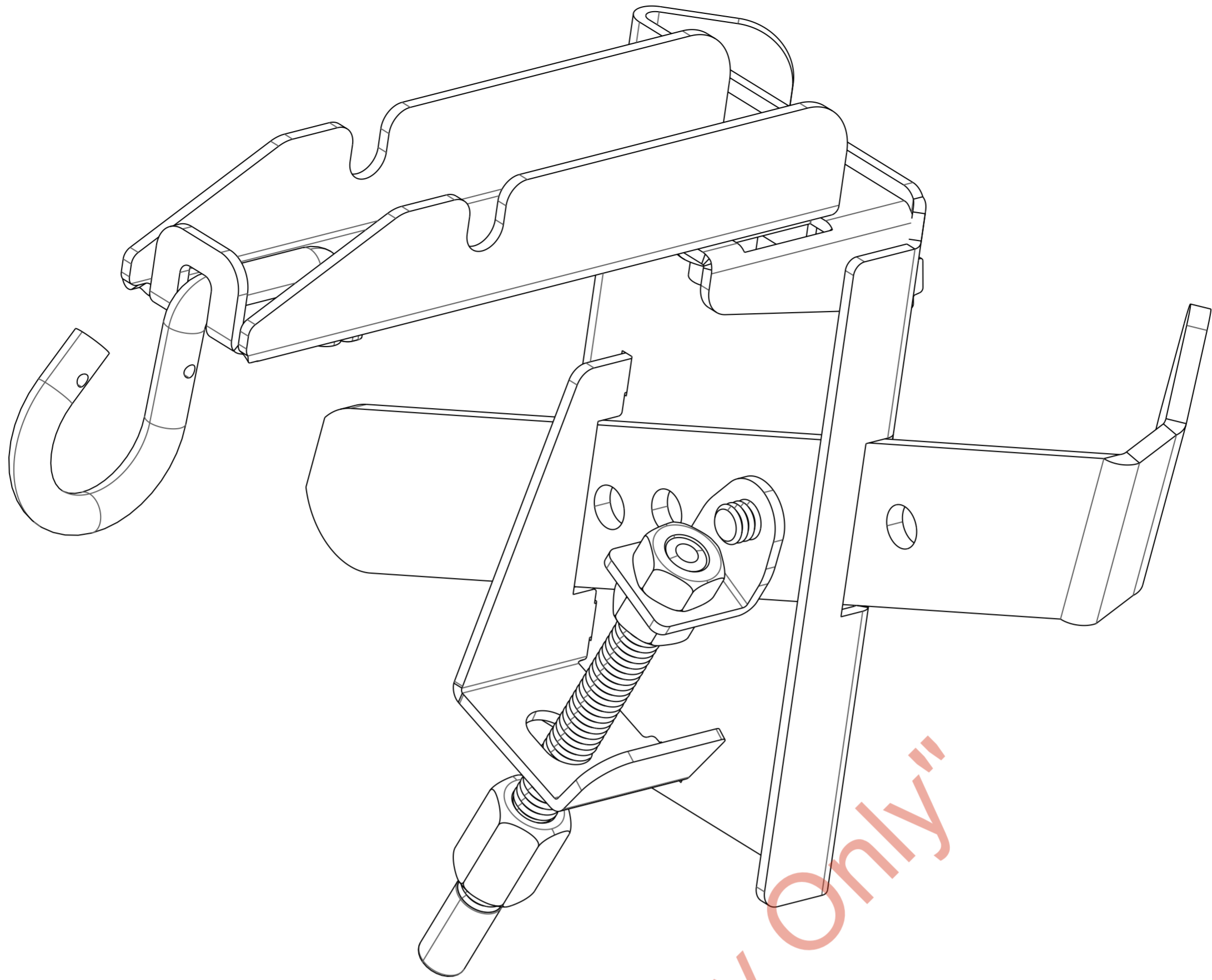

"Preview Copy Only"

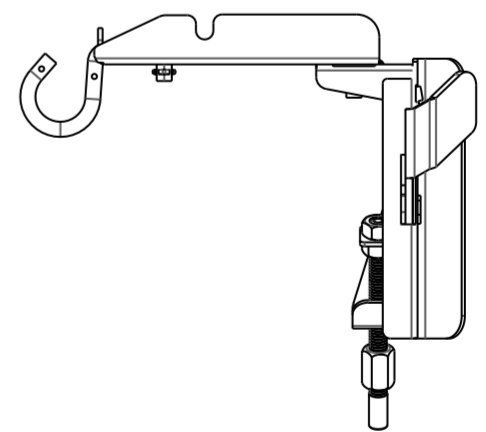
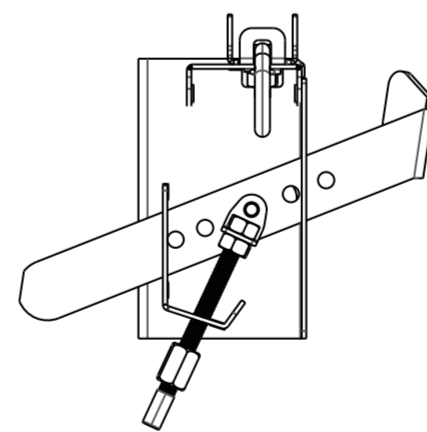
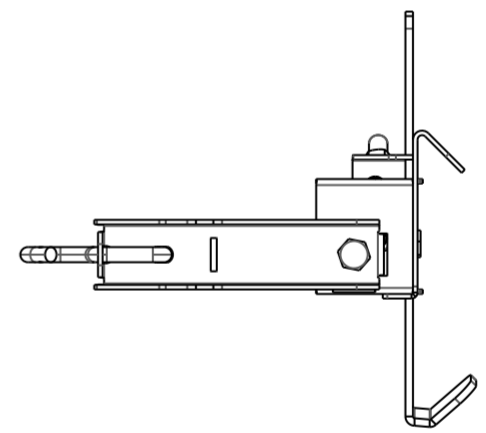

DO NOT SCALE / IF IN DOUBT ASK

THIS DOCUMENT IS
THE PROPERTY OF
LASERFAB AND MAY
NOT BE COPIED OR
TAMPERED WITH WITHOUT
CONSENT
PROTECTED BY SA DESIGNS
REGISTRATION No. 200601467

LaserFab

| | | | |
|-------------------|----------------------|---------------|------------|
| DRAWN BY: | M. STRAPPAZZON | APPROVED BY: | |
| DATE: | 21/04/2008 | ISSUED: | YES |
| FORMAT AVAILABLE: | PDF | LAST ISSUED: | 21/04/2008 |
| REVISION: | 1 | LAST UPDATED: | 21/04/2008 |
| SHEET NUMBER | 1 OF 1 | | |
| MATERIAL | MILD STEEL | | |
| FINISH | THERMAL DIFFUSION | | |
| PROCESS | ASSEMBLE | | |
| PART NUMBER | Q204008 | | |
| DESCRIPTION | DC I-BEAM SUSPENSION | | |
| PROJECT NUMBER | RAILWAY BRACKET | | |

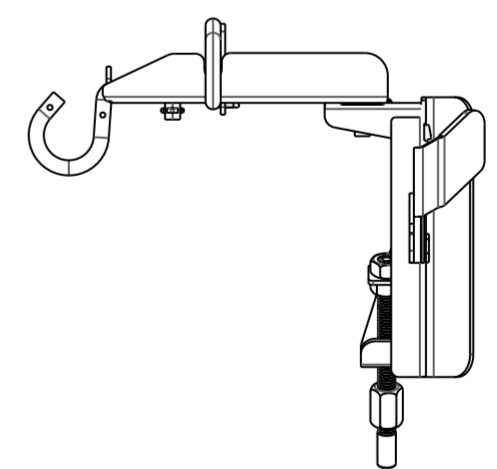
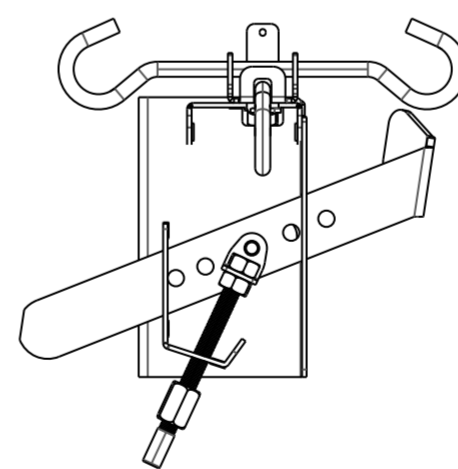
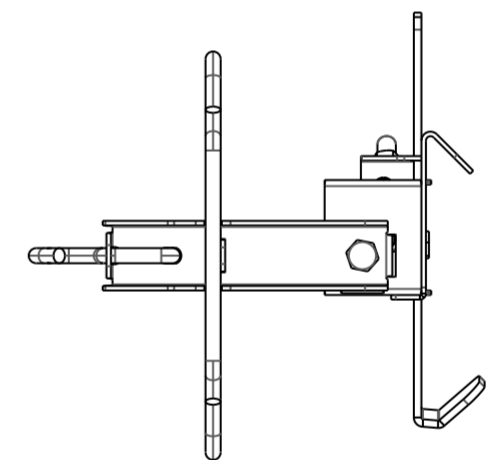
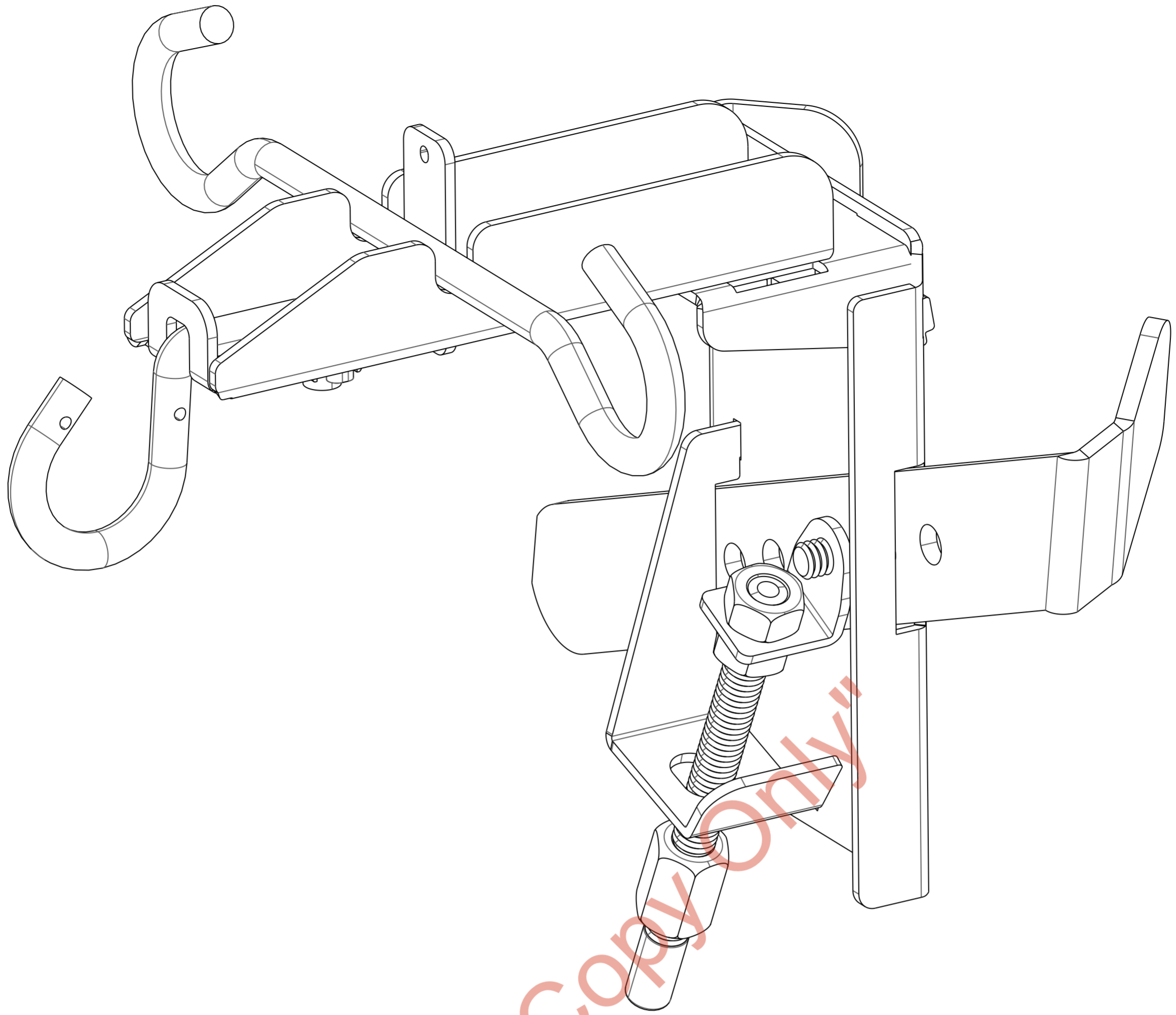

DO NOT SCALE / IF IN DOUBT ASK

THIS DOCUMENT IS
THE PROPERTY OF
LASERFAB AND MAY
NOT BE COPIED OR
TAMPERED WITH WITHOUT
CONSENT
PROTECTED BY SA DESIGNS
REGISTRATION No. 200601467

LaserFab

| | | | |
|-------------------|-----------------------|---------------|------------|
| DRAWN BY: | M. STRAPPAZZON | APPROVED BY: | |
| DATE: | 21/04/2008 | ISSUED: | YES |
| FORMAT AVAILABLE: | PDF | LAST ISSUED: | 21/04/2008 |
| REVISION: | 1 | LAST UPDATED: | 21/04/2008 |
| SHEET NUMBER | 1 OF 1 | | |
| MATERIAL | MILD STEEL | | |
| FINISH | THERMAL DIFFUSION | | |
| PROCESS | ASSEMBLE | | |
| PART NUMBER | Q204009 | | |
| DESCRIPTION | DC I-BEAM TERMINATION | | |
| PROJECT NUMBER | RAILWAY BRACKET | | |

