



**TRANSNET FREIGHT RAIL**, a division of

**TRANSNET SOC LTD**

Registration Number 1990/000900/30

[Hereinafter referred to as **Transnet**]

**REQUEST FOR QUOTATION [RFQ] No ERACTS3875-22184**

**FOR THE MODIFICATION OF ANTIVANDALISM AND REPLACEMENT OF LOCKING  
MECHANISM IN RELAY ROOMS**

**FOR DELIVERY TO: TRANSNET FREIGHT RAIL  
KOEDOESPOORT**

**ISSUE DATE: 23 AUGUST 2016**  
**CLOSING DATE: 6 SEPTEMBER 2016**  
**CLOSING TIME: 15:00**

**PLEASE BRING A VALID RFQ DOCUMENT ON THE DAY OF THE BRIEFING SESSION  
OTHERWISE RESPONDENTS WILL NOT BE ALLOWED TO BID**

**Section 1**  
**FOR THE MODIFICATION OF ANTIVANDALISM AND REPLACEMENT OF LOCKING**  
**MECHANISM IN RELAY ROOMS**

Quotations which must be completed as indicated in Section 2 of this RFQ are to be submitted as follows:

**METHOD:** [post and/or courier]  
**CLOSING VENUE:** The Secretariat, Transnet Freight Rail, Acquisition Council, Tender Box on the  
 Ground floor, Nzasm Building, corner of Paul Kruger and Minaar, Pretoria, 0001

**1 INVITATION TO BID**

Responses to this RFQ [hereinafter referred to as a **Bid**] are requested from persons, companies, close corporations or enterprises [hereinafter referred to as an **entity, Respondent or Bidder**].

<b>DESCRIPTION</b>	For the modification of antivandalism and replacement of locking mechanism in relay rooms.
<b>BID FEE AND BANKING DETAILS</b>	<b>This RFQ is issued free of charge.</b>
<b>INSPECT / COLLECT DOCUMENTS FROM</b>	The Office of Transnet Freight Rail, Advice Centre, Ground floor, Nzasm Building, Room G.16, corner of Paul Kruger and Minaar, Pretoria, 0001
<b>ISSUE DATE AND COLLECTION DATE DEADLINE</b>	Between 08:00 and 15:00 from 23 August 2016 till 29 August 2016
<b>COMPULSORY BRIEFING SESSION</b>	Yes Refer to point 2 below for details.
<b>CLOSING DATE</b>	<b>10:00 on Tuesday 5 September 2016</b> Bidders must ensure that bids are delivered timeously to the correct address. As a general rule, if a bid is late or delivered to the incorrect address, it will not be accepted for consideration.

Any additional information or clarification will be faxed or emailed to all Respondents, if necessary.

**2 FORMAL BRIEFING**

A compulsory information session will be conducted at Transnet Freight Rail, Infrastructure Maintenance Depot, 1 Trans Road, Silverton on the 30<sup>th</sup> August 2016

After the briefing session, various sites will be **(Respondents must provide their own transportation and beverages)**

**Contact person for directions:**

**Mr. Poppie Legodi**

**Cell no: 083 399 9624 or (012) 842 5310**

As the briefing session will be held in an operational area of Transnet, all people entering the premises **may be subjected to a substance abuse test**. This is a standard operational requirement for TFR, when entering any operational area in order that TFR may address the risk of injury. Any person that fails such test will not be permitted to enter the premises and thereby forfeits rights to be allowed access to the briefing session and will subsequently not be permitted to submit a bid for the tender.

- 2.1 A Certificate of Attendance in the form set out in Section 6 hereto must be completed and submitted with your Quotation as proof of attendance is required for a compulsory site meeting and/or RFQ briefing.
- 2.2 Respondents failing to attend the compulsory site meeting and/or RFQ briefing will be disqualified.
- 2.3 Respondents without a valid RFQ document in their possession will not be allowed to attend the site meeting and/or RFQ briefing.
- 2.4 The briefing session will start punctually at 10:00 and information will not be repeated for the benefit of Respondents arriving late.
- 2.5 Reflective Jackets and Safety shoes to be worn when visiting the site. Without the safety Clothing, respondents won't be allowed at the various sites.
- 2.6 Respondents will not be allowed at the briefing session if they don't have a copy of the RFQ document on the day of briefing session.

### 3 QUOTATION SUBMISSION

Quotations (inclusive of attachments) **in duplicate** must reach the Secretary, Transnet Acquisition Council before the closing hour on the date shown below, and must be enclosed in a sealed envelope which must have inscribed on the outside:

RFQ No:	ERACTS3875-22184
Description	THE MODIFICATION OF ANTIVANDALISM AND REPLACEMENT OF LOCKING MECHANISM IN RELAY ROOMS
Closing date and time:	6 September 2016, 10h00
Closing address	[Refer options in paragraph 4 below]

All envelopes must reflect the return address of the Respondent on the reverse side.

### 4 DELIVERY INSTRUCTIONS FOR RFQ

#### 4.1 Delivery by hand

If delivered by hand, the envelope is to be deposited in the Transnet tender box which is located in the foyer on the ground floor, Nzasm Building, cnr Paul Kruger and Minaar street, Pretoria and should be addressed as follows:

TRANSNET ACQUISITION COUNCIL  
 GROUND FLOOR  
 TENDER BOX  
 NZASM BUILDING  
 CORNER OF PAUL KRUGER AND MINNAAR STREET  
 PRETORIA  
 0001

The measurements of the "tender box slot" are 500mm wide x 100mm high, and Respondents must please ensure that response documents or files are not larger than the above dimensions. Responses which are too bulky [i.e. more than 100mm thick] must be split into two or more files, and placed in separate envelopes, each such envelope to be addressed as required in paragraph 3 above.

It should also be noted that the above tender box is located at the main entrance and is accessible to the public 24 hours a day, 7 days a week.

#### 4.2 Dispatch by courier

If dispatched by courier, the envelope must be addressed as follows and delivered to the Office of The Secretary, Transnet Acquisition Council and a signature obtained from that Office.

THE SECRETARY  
TRANSNET ACQUISITION COUNCIL  
NZASM BUILDING, ROOM G16  
CORNER OF PAUL KRUGER AND MINNAAR STREET  
PRETORIA  
0001

4.3 If responses are not delivered as stipulated herein, such responses will not be considered and will be treated as "UNRESPONSIVE."

4.4 No email or facsimile responses will be considered, unless otherwise stated herein.

The responses to this RFQ will be opened as soon as possible after the closing date and time. Transnet shall not, at the opening of responses, disclose to any other company any confidential details pertaining to the Quotations / information received, i.e. pricing, delivery, etc. The names and locations of the Respondents will be divulged to other Respondents upon request

#### 5 Responses to RFQ

Responses to this RFQ [Quotations] must not include documents or reference relating to any other quotation or proposal. Any additional conditions must be embodied in an accompanying letter.

#### 6 Broad-Based Black Economic Empowerment [B-BBEE]

Transnet fully endorses and supports the Government's Broad-Based Black Economic Empowerment Programme and it would therefore prefer to do business with local business enterprises who share these same values. As described in more detail in the attached B-BBEE Claim Form Transnet will allow a "preference" to companies who provide a valid B-BBEE Verification Certificate.

The value of this bid is estimated to be less than R1 000 000 (all applicable taxes included); and therefore the **80/20** system shall be applicable.

Respondents are required to complete Annexure A [the B-BBEE Preference Point Claim Form] and submit it together with proof of their B-BBEE Status as stipulated in the Claim Form in order to obtain preference points for their B-BBEE status.

**Note: Failure to submit a valid and original B-BBEE certificate or a certified copy thereof at the Closing Date of this RFQ will result in a score of zero being allocated for B-BBEE.**

**7 Communication**

Respondents are warned that a response will be liable for disqualification should any attempt be made by a Respondent either directly or indirectly to canvass any officer(s) or employee of Transnet in respect of this RFQ between the closing date and the date of the award of the business.

A Respondent may, however, before the closing date and time, direct any written enquiries relating to the RFQ to the following Transnet employee:

Name: **TUMELO SEDIKELO** Email: **tumelo.sedikelo@transnet.net**  
Telephone: **012 315 2132**

Respondents may also, at any time after the closing date of the RFQ, communicate with the Secretariat of the Transnet Acquisition Council on any matter relating to its RFQ response:

Name	Email address	Telephone	Fax
Gloria Nhlapo	<a href="mailto:Gloria.nhlapo@transnet.net">Gloria.nhlapo@transnet.net</a>	012 315 4124	011 774 9115
Morris Mhlongo	<a href="mailto:Morris.mhlongo@transnet.net">Morris.mhlongo@transnet.net</a>	012 315 4122	011 774 9115

**8 Legal Compliance**

The successful Respondent shall be in full and complete compliance with any and all applicable national and local laws and regulations.

**9 Changes to Quotations**

Changes by the Respondent to its submission will not be considered after the closing date and time.

**10 Pricing**

All prices must be quoted in South African Rand on a fixed price basis, excluding VAT.

**11 Prices Subject to Confirmation**

Prices quoted which are subject to confirmation will not be considered.

**12 Binding Offer**

Any Quotation furnished pursuant to this Request shall be deemed to be an offer. Any exceptions to this statement must be clearly and specifically indicated.

**13 Disclaimers**

Transnet is not committed to any course of action as a result of its issuance of this RFQ and/or its receipt of a Quotation in response to it. Please note that Transnet reserves the right to:

- modify the RFQ's goods / service(s) and request Respondents to re-bid on any changes;
- reject any Quotation which does not conform to instructions and specifications which are detailed herein;
- disqualify Quotations submitted after the stated submission deadline;
- not necessarily accept the lowest priced Quotation or an alternative bid;
- reject all Quotations, if it so decides;

- place an order in connection with this Quotation at any time after the RFQ's closing date;
- award only a portion of the proposed goods / service/s which are reflected in the scope of this RFQ;
- split the award of the order/s between more than one Supplier/Service Provider should it at Transnet's discretion be more advantageous in terms of, amongst others, cost or developmental considerations ;  
or
- make no award at all.

Should a contract be awarded on the strength of information furnished by the Respondent, which after conclusion of the contract, is proved to have been incorrect, Transnet reserves the right to cancel the contract.

Transnet reserves the right to award business to the highest scoring bidder/s unless objective criteria justify the award to another bidder.

Transnet reserves the right to conduct Post Tender Negotiations (PTN) with selected Respondents or any number of short-listed Respondents, such PTN to include, at Transnet's discretion, any evaluation criteria listed in the RFQ document.

Should the preferred bidder fail to sign or commence with the contract within a reasonable period after being requested to do so, Transnet reserves the right to award the business to the next highest ranked bidder, provided that he/she is still prepared to provide the required goods at the quoted price.

PREVIEW COPY

## 14 Project Specification/Scope of Work

### 14.1 Scope

- Modify the incorrectly pre-ordered anti-vandalism apparatus case lids (1500mm BBF3709) to the required lid specifications (1300mm BBD5575) in order for the lids to correctly fit the required apparatus case boxes installed in the Koedoespoort Depot region under the jurisdiction of the depot engineer, Rail Network Planning Koedoespoort.
- Replace current locking mechanism with new mechanism, standardise the keys to be able to unlock any Relay room under Koedoespoort depot. The respondent to take their own measurement on site to quantify all the required material to execute the job.

### 14.2 Standards

- Unless otherwise specified all material and equipment supplied shall comply with the current edition of the relevant SANS, BS, IEC or Transnet Freight Rail publication where applicable.
- The respondent shall carry out the work in accordance with the Contract Specifications and in a thorough and workmanlike manner. Any sub-standard work shall be rejected and redone at the respondents cost.
- The final acceptance of the work rests with Transnet Freight Rail's designated Technical officer.
- The respondent will only work depot normal working hours (Monday to Friday 07:00 till 16:30)

### 14.3 Description of work

- Modify the each of the 1500mm (BBF3709) apparatus lids to the exact specifications of a set out for the 1300mm (BBD5575) lid.
- The following apparatus cases are to be upgraded with the new anti-vandalism lids after modification:

APPARATUS CASE UPGRADE-PYRAMID 5641
APPARATUS CASE UPGRADE-PYRAMID 5642
APPARATUS CASE UPGRADE-PYRAMID 5643
APPARATUS CASE UPGRADE-PYRAMID 5643A
APPARATUS CASE UPGRADE-PYRAMID 5644
APPARATUS CASE UPGRADE-PYRAMID 5645
APPARATUS CASE UPGRADE-PYRAMID 5646
APPARATUS CASE UPGRADE-PYRAMID 5647
APPARATUS CASE UPGRADE-PYRAMID 5648
APPARATUS CASE UPGRADE-PYRAMID 5649
APPARATUS CASE UPGRADE-PYRAMID 5651
APPARATUS CASE UPGRADE-PYRAMID 5652
APPARATUS CASE UPGRADE-PYRAMID 5653
APPARATUS CASE UPGRADE-PYRAMID 5653A
APPARATUS CASE UPGRADE-PYRAMID 5654
APPARATUS CASE UPGRADE-PYRAMID 5656
APPARATUS CASE UPGRADE-PYRAMID 5657
APPARATUS CASE UPGRADE-PYRAMID 5658
APPARATUS CASE UPGRADE-PYRAMID 5659

APPARATUS CASE UPGRADE-PYRAMID 5660
APPARATUS CASE UPGRADE-PYRAMID 5661A
APPARATUS CASE UPGRADE-PYRAMID 5662
APPARATUS CASE UPGRADE-PYRAMID 5663
APPARATUS CASE UPGRADE-PYRAMID 5664
APPARATUS CASE UPGRADE-PYRAMID 5665
APPARATUS CASE UPGRADE-PYRAMID 5666
APPARATUS CASE UPGRADE-PYRAMID 5667
APPARATUS CASE UPGRADE-PYRAMID 5668
APPARATUS CASE UPGRADE-PYRAMID 5669
APPARATUS CASE UPGRADE-PYRAMID 5670
APPARATUS CASE UPGRADE-PYRAMID 5671
APPARATUS CASE UPGRADE-PYRAMID 5672
APPARATUS CASE UPGRADE-PYRAMID 5673
APPARATUS CASE UPGRADE-PYRAMID 5674
APPARATUS CASE UPGRADE-PYRAMID 5675
APPARATUS CASE UPGRADE-PYRAMID 5676
APPARATUS CASE UPGRADE-PYRAMID 5677
APPARATUS CASE UPGRADE-PYRAMID 5678
APPARATUS CASE UPGRADE-PYRAMID 5679
APPARATUS CASE UPGRADE-PYRAMID 5680

- Replace the current locking mechanism with a new mechanism and standardise the keys to ensure that all the relays rooms are using one key.
- The following Relay Rooms & Battery Rooms doors are to be replaced with the new locking mechanism:

Station Name	Relay Room	Battery Room
Kameelrif (02AR044)	1	1
Baviaanspoort (02AR019)	1	1
Leeuport (02AR021)	1	1
SNV (02AX231)	1	1
Panorpoort (02AX241)	1	1
Van DerMerwe (02AX245)	1	1
Rayton	1	1

#### 14.4 Supply of material

- The 1500mm (BBF3709) apparatus case lids will be supplied by the Koedoespoort Infra Depot personal.
- The Respondent must supply any additional material (that might be required for the installation of apparatus case doors), new locking mechanism for the safety doors, labour and transport and accommodation for the execution of the work.

#### 14.5 Safety

- The work will be performed under normal operating conditions (i.e. between trains).



- The Respondent will issue all workers employed by him with the necessary protective clothing applicable to the type of work being performed.
- Safety awareness training is required for all workers who will work in the vicinity of the railway line. This is done once-off by Transnet Freight Rail free of Charge, and is thereafter the responsibility of the Respondent.
- During the execution of the contract, the Respondent will be required to inform the Technical Officer of any staff changes and provide the qualifications of the replacement.
- No open fires will be permitted on site. Any claims arising from the making of such fires will be for the cost of the respondent.
- The workplace must be cleaned of scrap material (i.e. papers, cable of cuts, tins etc.) after every workday.

#### **14.6 Respondent's Obligation**

- The obligation to look after the contract work and everything connected therewith shall rest solely with the Respondent who shall take all necessary precautions to protect the public, the property of the public, the property and personnel of Transnet and all other persons on terrain from injury.
- The Respondent must also protect adjoining properties from trespass or damage during the progress of the work. The Respondent shall also be liable to compensate any person who may suffer damages, recoverable in law, from the Respondent and/or from Transnet, by reason of the said work, and hereby indemnifies Transnet Limited against any claims that may be made by any person whatsoever in respect of any damages or any other losses which may be incurred by such person.
- The respondent must quote us on the rates we are going to use for the duration of the contract in terms of the material, equipment, labour and transport for the execution of the work.
- The rate shall not be changed for the duration of the contract.

#### **14.7 Handling over of Workplaces**

- The respondent shall complete the work including his testing and commissioning within the prescribed time.
- On completion of the work, the Technical officer/Project manager will inspect the works where after the respondent must issue his V.T-invoice within seven days. The respondent shall be entitled to receive payment within 30 days from month end statement.
- The commissioning and testing will be done according to specification. The original commissioning sheet will be placed (in an applicable plastic holder) in the apparatus case and a copy thereof will be given to the Technical officer / Project manager.
- The respondent will be liable for any damages to Transnet Freight Rail property or Signal apparatus and it will be repaired and tested by the respondent for his own cost.

#### **14.8 Site Books**

- The Respondent will provide a site instruction book on site for the duration of the contract.
- The site instruction book will be used by the Project Manager for issuing instructions to the Respondent as well as a daily diary.
- In the daily diary the Respondent will record a detailed description of the work done on a daily basis.
- This book will not be removed from the site without the permission of the Project Manager.
- These books become the property of Transnet Freight Rail

#### **14.9 Duration of contract**

- The contract will commence one week after date of letter of acceptance.

**Transnet urges its clients, suppliers and the general public to report any fraud or corruption to**

**TIP-OFFS ANONYMOUS: 0800 003 056**

**PREVIEW COPY**

**SECTION 2****15 Evaluation Criteria and returnable documents****Evaluation Criteria**

Transnet will utilise the following criteria [not necessarily in this order] in choosing a Supplier/Service Provider, if so required:

<b>Criterion/Criteria</b>	<b>Explanation</b>
<b>Administrative responsiveness</b>	<ul style="list-style-type: none"> <li>• Whether bids has been lodged on time</li> <li>• Verify the validity of all returnable documents</li> <li>• Completeness of response and returnable documents</li> </ul>
<b>Substantive responsiveness</b>	<ul style="list-style-type: none"> <li>• Whether the bid contains a price offer</li> <li>• Whether the bid materially complies with the scope and /or specification given (Section 7 ~ fully completed clause by clause compliance to project specification)</li> <li>• Certificate of attendance of compulsory Information Briefing session (Section 6)</li> </ul>
<b>Final weighted evaluation based on 80/20 preference point</b>	<ul style="list-style-type: none"> <li>• Pricing and price basis [firm]</li> <li>• B-BBEE status of company – Preference point will be awarded to a bidder for attaining the B-BBEE status level of contribution in accordance with the table indicated in Annexure A; B-BBEE Claim Form.</li> </ul>

**16 VALIDITY PERIOD**

This RFQ is validity period is until **30 November 2016**

**17 Disclosure of Prices Quoted**

Respondents must indicate here whether Transnet may disclose their quoted prices and conditions to other Respondents

YES  NO

**18 Returnable Documents**

**Returnable Documents** means all the documents, Sections and Annexures, as listed in the tables below.

**All Returnable Sections, as indicated in the header and footer of the relevant pages, must be signed, stamped and dated by the Respondent.**

- a) Respondents are required to submit with their Quotations the **mandatory Returnable Documents**, as detailed below.

\_\_\_\_\_  
Respondent's Signature

\_\_\_\_\_  
Date & Company Stamp

***Failure to provide all these Mandatory Returnable Documents at the Closing Date and time of this RFQ will result in a Respondent's disqualification. Respondents are therefore urged to ensure that all these Documents are returned with their Quotations.***

Please confirm submission of these mandatory Returnable Documents by so indicating [Yes or No] in the tables below:

<b>Mandatory Returnable Documents</b>	<b>Submitted [Yes or No]</b>
SECTION 3 : Quotation Form/Pricing schedule	
SECTION 7 : Fully completed clause by clause compliance to project specification	
SECTION 6 : Certificate of attendance of compulsory Information Briefing session	

- b) In addition to the requirements of section (a) above, Respondents are further required to submit with their Quotations the following **essential Returnable Documents** as detailed below.

***Failure to provide all these Returnable Documents may result in a Respondent's disqualification. Respondents are therefore urged to ensure that all these documents are returned with their Quotations.***

<b>Essential Returnable Documents</b>	<b>Submitted [Yes or No]</b>
SECTION 2 : Evaluation criteria and list of returnable documents	
- SECTION 4 : RFQ Declaration and Breach of Law Form	
- Valid and original, or a certified copy, of your entity's B-BBEE Verification Certification as per the requirements stipulated in Annexure A: B-BBEE Claims Form Note: failure to provide these required documents at the closing date and time of the RFQ will result in an automatic score of zero being allocated for preference	
- Original valid Tax Clearance Certificate [Consortia / Joint Ventures must submit a separate Tax Clearance Certificate for each party]	
- SECTION 5 : B-BBEE Preference Points Claim Form	
- SECTION 6 : Certificate of attendance of compulsory Information Briefing session	
- SECTION 7 : Fully completed clause by clause compliance to project specification	
ANNEXURE A – B-BBEE Preference Points Claim Form	

#### **CONTINUED VALIDITY OF RETURNABLE DOCUMENTS**

The successful Respondent will be required to ensure the validity of all returnable documents, including but not limited to its Tax Clearance Certificate and valid B-BBEE Verification Certificate, for the duration of any contract emanating from this RFQ. Should the Respondent be awarded the contract [**the Agreement**] and fail to present Transnet with such renewals as and when they become due, Transnet shall be entitled, in addition to any other rights and remedies that it may have in terms of the eventual Agreement, to terminate such Agreement forthwith without any liability and without prejudice to any claims which Transnet may have for damages against the Respondent.

Respondent's Signature

Date & Company Stamp

### SECTION 3 QUOTATION FORM

I/We \_\_\_\_\_  
hereby offer to supply the goods/services at the prices quoted in the Price Schedule below, in accordance with the conditions related thereto.

I/We agree to be bound by those terms and conditions in:

- the Standard RFQ Terms and Conditions for the Supply of Goods or Services to Transnet; and
- any other standard or special conditions mentioned and/or embodied in this Request for Quotation.

I/We accept that unless Transnet should otherwise decide and so inform me/us, this Quotation [and, if any, its covering letter and any subsequent exchange of correspondence], together with Transnet's acceptance thereof shall constitute a binding contract between Transnet and me/us.

I/We further agree that if, after I/we have been notified of the acceptance of my/our Quotation, I/we fail to deliver the said goods/service/s within the delivery lead-time quoted, Transnet may, without prejudice to any other legal remedy which it may have, cancel the order and recover from me/us any expenses incurred by Transnet in calling for Quotations afresh and/or having to accept any less favourable offer.

#### Price Schedule

I/We quote as follows for the goods required, on a "delivered nominated destination" basis, excluding VAT:

DESCRIPTION	QUANTITY	UNIT PRICE	TOTAL AMOUNT
APPARATUS CASE UPGRADE-PYRAMID 5642	1		
APPARATUS CASE UPGRADE-PYRAMID 5643	1		
APPARATUS CASE UPGRADE-PYRAMID 5643	1		
APPARATUS CASE UPGRADE-PYRAMID 5644	1		
APPARATUS CASE UPGRADE-PYRAMID 5645	1		
APPARATUS CASE UPGRADE-PYRAMID 5646	1		
APPARATUS CASE UPGRADE-PYRAMID 5647	1		
APPARATUS CASE UPGRADE-PYRAMID 5648	1		
APPARATUS CASE UPGRADE-PYRAMID 5649	1		

\_\_\_\_\_  
Respondent's Signature

\_\_\_\_\_  
Date & Company Stamp

APPARATUS CASE UPGRADE-PYRAMID 5651	1		
APPARATUS CASE UPGRADE-PYRAMID	1		
APPARATUS CASE UPGRADE-PYRAMID 5652	1		
APPARATUS CASE UPGRADE-PYRAMID 5653	1		
APPARATUS CASE UPGRADE-PYRAMID 5653A	1		
APPARATUS CASE UPGRADE-PYRAMID 5654	1		
APPARATUS CASE UPGRADE-PYRAMID 5656	1		
APPARATUS CASE UPGRADE-PYRAMID 5657	1		
APPARATUS CASE UPGRADE-PYRAMID 5658	1		
APPARATUS CASE UPGRADE-PYRAMID 5659	1		
APPARATUS CASE UPGRADE-PYRAMID 5660	1		
APPARATUS CASE UPGRADE-PYRAMID 5661A	1		
APPARATUS CASE UPGRADE-PYRAMID 5662	1		
APPARATUS CASE UPGRADE-PYRAMID 5663	1		
APPARATUS CASE UPGRADE-PYRAMID 5664	1		
APPARATUS CASE UPGRADE-PYRAMID 5665	1		
APPARATUS CASE UPGRADE-PYRAMID 5666	1		
APPARATUS CASE UPGRADE-PYRAMID 5667	1		
APPARATUS CASE UPGRADE-PYRAMID 5668	1		
APPARATUS CASE UPGRADE-PYRAMID 5669	1		
APPARATUS CASE UPGRADE-PYRAMID 5670	1		
APPARATUS CASE UPGRADE-PYRAMID 5671	1		
APPARATUS CASE UPGRADE-PYRAMID 5672	1		

PREVIEW COPY

\_\_\_\_\_  
Respondent's Signature

\_\_\_\_\_  
Date & Company Stamp

APPARATUS CASE UPGRADE-PYRAMID 5673	1		
APPARATUS CASE UPGRADE-PYRAMID 5674	1		
APPARATUS CASE UPGRADE-PYRAMID 5675	1		
APPARATUS CASE UPGRADE-PYRAMID 5676	1		
APPARATUS CASE UPGRADE-PYRAMID 5678	1		
APPARATUS CASE UPGRADE-PYRAMID 5679	1		
APPARATUS CASE UPGRADE-PYRAMID 5680	1		
REPLACEMENT SAFETY LOCK MECHANISM RAY	1		
REPLACEMENT SAFETY LOCK MECHANISM VDM	1		
REPLACEMENT SAFETY LOCK MECHANISM PAP	1		
REPLACEMENT SAFETY LOCK MECHANISM GNP	1		
REPLACEMENT SAFETY LOCK MECHANISM KIF	1		
REPLACEMENT SAFETY LOCK MECHANISM BVS	1		
REPLACEMENT SAFETY LOCK MECHANISM LFN	1		
	<b>Total Value (Exclusive VAT)</b>		
	<b>VAT (14%)</b>		
	<b>Total Value (Inclusive VAT)</b>		

**Delivery Lead Time from date of purchase order:** \_\_\_\_\_ [days/weeks]

**Notes to Pricing:**

- All Prices must be quoted in South African Rand, exclusive of VAT
- To facilitate like-for-like comparison bidders must submit pricing strictly in accordance with this price schedule and not utilise a different format. Deviation from this pricing schedule could result in a bid being disqualified.

Please note that should you have offered a discounted price(s), Transnet will only consider such price discount(s) in the final evaluation stage if offered on an unconditional basis.

**By signing this Quotation Form the Respondent is deemed to acknowledge that he/she has made himself/herself thoroughly familiar, and agrees, with all the conditions governing this RFQ,**

\_\_\_\_\_  
Respondent's Signature

\_\_\_\_\_  
Date & Company Stamp

**including those contained in any printed form stated to form part hereof, including but not limited to the documents stated below and Transnet SOC Ltd will recognise no claim for relief based on an allegation that the Respondent overlooked any such condition or failed properly to take it into account for the purpose of calculating tendered prices or otherwise:**

1. Specifications included in this RFQ
2. The following documents all of which are available on Transnet’s website or upon request:
  - 2.1. General Bid Conditions;
  - 2.2. Standard RFQ Terms and Conditions for the Supply of Goods or Services to Transnet;
  - 2.3. Supplier Integrity Pact;
  - 2.4. Non-disclosure Agreement; and
  - 2.5. Vendor Application Form and all supporting documents (first time vendors only)

Alternatively, for all existing vendors, please provide vendor number(s) here:

Transnet Operating Division	Unique Vendor Number	Yes / No
Transnet Group		
TFR, etc.		

In the Yes/No column above, please confirm that all the information e.g. company address and contact details, banking details etc. are still correct as at the time of allocation of the vendor number(s). Alternatively, Respondents are required to provide the updated information with their bid submission.

SIGNED at \_\_\_\_\_ on this \_\_\_\_\_ day of \_\_\_\_\_ 20\_\_

SIGNATURE OF WITNESSES

ADDRESS OF WITNESSES

1 \_\_\_\_\_  
Name \_\_\_\_\_

\_\_\_\_\_

2 \_\_\_\_\_  
Name \_\_\_\_\_

\_\_\_\_\_

SIGNATURE OF RESPONDENT’S AUTHORISED REPRESENTATIVE: \_\_\_\_\_

NAME: \_\_\_\_\_

DESIGNATION: \_\_\_\_\_

\_\_\_\_\_  
Respondent’s Signature

\_\_\_\_\_  
Date & Company Stamp



**SECTION 4**

**RFQ DECLARATION AND BREACH OF LAW FORM**

NAME OF ENTITY: \_\_\_\_\_

We \_\_\_\_\_ do hereby certify that:

1. Transnet has supplied and we have received appropriate responses to any/all questions [as applicable] which were submitted by ourselves for RFQ Clarification purposes;
2. we have received all information we deemed necessary for the completion of this Request for Quotation [RFQ];
3. we have been provided with sufficient access to the existing Transnet facilities/sites and any and all relevant information relevant to the Supply of the Goods as well as Transnet information and Employees, and has had sufficient time in which to conduct and perform a thorough due diligence of Transnet's operations and business requirements and assets used by Transnet. Transnet will therefore not consider or permit any pre- or post-contract verification or any related adjustment to pricing, service levels or any other provisions/conditions based on any incorrect assumptions made by the Respondent in arriving at his Bid Price.
4. at no stage have we received additional information relating to the subject matter of this RFQ from Transnet sources, other than information formally received from the designated Transnet contact(s) as nominated in the RFQ documents;
5. we are satisfied, insofar as our entity is concerned, that the processes and procedures adopted by Transnet in issuing this RFQ and the requirements requested from Bidders in responding to this RFQ have been conducted in a fair and transparent manner; and
6. furthermore, we declare that a family, business and/or social relationship **exists / does not exist** [delete as applicable] between an owner / member / director / partner / shareholder of our entity and an employee or board member of the Transnet Group including any person who may be involved in the evaluation and/or adjudication of this Bid.
7. In addition, we declare that an owner / member / director / partner / shareholder of our entity **is / is not** [delete as applicable] an employee or board member of the Transnet Group.
8. If such a relationship as indicated in paragraph 6 and/or 7 exists, the Respondent is to complete the following section:

FULL NAME OF OWNER/MEMBER/DIRECTOR/  
PARTNER/SHAREHOLDER:

ADDRESS:

\_\_\_\_\_  
\_\_\_\_\_

Indicate nature of relationship with Transnet:

\_\_\_\_\_  
\_\_\_\_\_

\_\_\_\_\_  
Respondent's Signature

\_\_\_\_\_  
Date & Company Stamp

*[Failure to furnish complete and accurate information in this regard will lead to the disqualification of a response and may preclude a Respondent from doing future business with Transnet]*

9. We declare, to the extent that we are aware or become aware of any relationship between ourselves and Transnet [other than any existing and appropriate business relationship with Transnet] which could unfairly advantage our entity in the forthcoming adjudication process, we shall notify Transnet immediately in writing of such circumstances.

**BREACH OF LAW**

10. We further hereby certify that *I/we have/have not been* [delete as applicable] found guilty during the preceding 5 [five] years of a serious breach of law, including but not limited to a breach of the Competition Act, 89 of 1998, by a court of law, tribunal or other administrative body. The type of breach that the Respondent is required to disclose excludes relatively minor offences or misdemeanours, e.g. traffic offences. This includes the imposition of an administrative fine or penalty.

Where found guilty of such a serious breach, please disclose:

NATURE OF BREACH:

\_\_\_\_\_

\_\_\_\_\_

\_\_\_\_\_

DATE OF BREACH: \_\_\_\_\_

Furthermore, I/we acknowledge that Transnet SOC Ltd reserves the right to exclude any Respondent from the bidding process, should that person or entity have been found guilty of a serious breach of law, tribunal or regulator obligation.

SIGNED at \_\_\_\_\_ on this \_\_\_\_\_ day of \_\_\_\_\_ 20\_\_\_\_

For and on behalf of _____	AS WITNESS:
duly authorized here	
Name:	Name:
Position:	Position:
Signature:	Signature:
Date:	Registration No of Company/CC _____
Place:	Registration Name of Company/CC _____

\_\_\_\_\_  
Respondent's Signature

\_\_\_\_\_  
Date & Company Stamp

## SECTION 5

## ANNEXURE A: B-BBEE PREFERENCE POINTS CLAIM FORM

This preference form contains general information and serves as a claim for preference points for Broad-Based Black Economic Empowerment [B-BBEE] Status Level of Contribution.

## 1. INTRODUCTION

- 1.1 A total of 20 preference points shall be awarded for B-BBEE Status Level of Contribution.
- 1.2 Failure on the part of a Bidder to fill in and/or to sign this form and submit a B-BBEE Verification Certificate from a Verification Agency accredited by the South African Accreditation System [SANAS] or a Registered Auditor approved by the Independent Regulatory Board of Auditors [IRBA] or an Accounting Officer as contemplated in the Close Corporation Act [CCA] together with the bid will be interpreted to mean that preference points for B-BBEE Status Level of Contribution are not claimed.
- 1.3 Transnet reserves the right to require of a Bidder, either before a Bid is indicated or at any time subsequently, to substantiate any claim in regard to preferences, in any manner required by Transnet.

## 2. GENERAL DEFINITIONS

- 2.1 "all applicable taxes" include value-added tax, pay as you earn, income tax, unemployment insurance fund contributions and skills development levies;
- 2.2 "B-BBEE" means broad-based black economic empowerment as defined in section 1 of the Broad-Based Black Economic Empowerment Act;
- 2.3 "B-BBEE status of contributor" means the B-BBEE status received by a measured entity based on its overall performance using the relevant scorecard contained in the Codes of Good Practice on Black Economic Empowerment, issued in terms of section 9(1) of the Broad-Based Black Economic Empowerment Act;
- 2.4 "Bid" means a written offer in a prescribed or stipulated form in response to an invitation by Transnet for the provision of goods, works or services;
- 2.5 "Broad-Based Black Economic Empowerment Act" means the Broad-Based Black Economic Empowerment Act, 2003 [Act No. 53 of 2003];
- 2.6 "comparative price" means the price after the factors of a non-firm price and all unconditional discounts that can be utilised have been taken into consideration;
- 2.7 "consortium or joint venture" means an association of persons for the purpose of combining their expertise, property, capital, efforts, skills and knowledge in an activity for the execution of a contract;
- 2.8 "contract" means the agreement that results from the acceptance of a bid by Transnet;
- 2.9 "EME" means any enterprise with an annual total revenue of R5 [five] million or less as per the 2007 version of the B-BBEE Codes of Good Practice and means any enterprise with an annual total revenue of R10 [ten] million or less as per the Revised Codes of Good Practice issued on 11

---

 Respondent's Signature

---

 Date & Company Stamp

October 2013 in terms of Government Gazette No. 36928;

- 2.10 **"firm price"** means the price that is only subject to adjustments in accordance with the actual increase or decrease resulting from the change, imposition, or abolition of customs and excise duty and any other duty, levy, or tax, which, in terms of the law or regulation, is binding on the contractor and demonstrably has an influence on the price of any supplies, or the rendering costs of any service, for the execution of the contract;
- 2.11 **"functionality"** means the measurement according to predetermined norms, as set out in the bid documents, of a service or commodity that is designed to be practical and useful, working or operating, taking into account, among other factors, the quality, reliability, viability and durability of a service and the technical capacity and ability of a bidder;
- 2.12 **"non-firm prices"** means all prices other than "firm" prices;
- 2.13 **"person"** includes reference to a juristic person;
- 2.14 **"QSE"** means any enterprise with an annual total revenue between R5 [five] million and R35 [thirty five] million as per the 2007 version of the B-BBEE Codes of Good Practice and means any enterprise with an annual total revenue of between R10 [ten] million and R50 [fifty] million as per the Revised Codes of Good Practice issued on 11 October 2013 in terms of Government Gazette No. 36928
- 2.15 **"rand value"** means the total estimated value of a contract in South African currency, calculated at the time of bid invitations, and includes all applicable taxes and excise duties;
- 2.16 **"subcontract"** means the primary contractor's assigning or leasing or making out work to, or employing another person to support such primary contractor in the execution of part of a project in terms of the contract;
- 2.17 **"total revenue"** bears the same meaning assigned to this expression in the Codes of Good Practice on Black Economic Empowerment, issued in terms of section 9(1) of the Broad-Based Black Empowerment Act and promulgated in the Government Gazette on 9 February 2007;
- 2.18 **"trust"** means the arrangement through which the property of one person is made over or bequeathed to a trustee to administer such property for the benefit of another person; and
- 2.19 **"trustee"** means any person, including the founder of a trust, to whom property is bequeathed in order for such property to be administered for the benefit of another person.

### 3. ADJUDICATION USING A POINT SYSTEM

- 3.1 The Bidder obtaining the highest number of total points for the evaluation criteria as enumerated in Section 2 of the RFP will be awarded the contract, unless objective criteria justifies the award to another bidder.
- 3.2 Preference points shall be calculated after prices have been brought to a comparative basis taking into account all factors of non-firm prices and all unconditional discounts.
- 3.3 Points scored will be rounded off to 2 [two] decimal places.
- 3.4 In the event of equal points scored, the Bid will be awarded to the Bidder scoring the highest number of preference points for B-BBEE.
- 3.5 However, when functionality is part of the evaluation process and two or more Bids have scored

Respondent's Signature

Date & Company Stamp

equal points including equal preference points for B-BBEE, the successful Bid will be the one scoring the highest score for functionality.

- 3.6 Should two or more Bids be equal in all respect, the award shall be decided by the drawing of lots.

**4. POINTS AWARDED FOR B-BBEE STATUS LEVEL OF CONTRIBUTION**

- 4.1 In terms of the Preferential Procurement Regulations, 2011, preference points shall be awarded to a Bidder for attaining the B-BBEE status level of contribution in accordance with the table below:

B-BBEE Status Level of Contributor	Number of Points [Maximum 20]
1	20
2	18
3	16
4	12
5	8
6	6
7	4
8	2
Non-compliant contributor	0

- 4.2 Bidders who qualify as EMEs in terms of the 2007 version of the Codes of Good Practice must submit a certificate issued by an Accounting Officer as contemplated in the CCA or a Verification Agency accredited by SANAS or a Registered Auditor. Registered auditors do not need to meet the prerequisite for IRBA's approval for the purpose of conducting verification and issuing EME's with B-BBEE Status Level Certificates.
- 4.3 Bidders who qualify as EMEs in terms of the Revised Codes of Good Practice issued on 11 October 2013 in terms of Government Gazette No. 36928 are only required to obtain a sworn affidavit on an annual basis confirming that the entity has an Annual Total Revenue of R10 million or less and the entity's Level of Black ownership.
- 4.4 In terms of the 2007 version of the Codes of Good Practice, Bidders other than EMEs must submit their original and valid B-BBEE status level verification certificate or a certified copy thereof, substantiating their B-BBEE rating issued by a Registered Auditor approved by IRBA or a Verification Agency accredited by SANAS.
- 4.5 The Department of Trade and Industry recently revised the Codes of Good Practice on 11 October 2013 [Government Gazette No. 36928]. The Revised Codes will replace the Black Economic Empowerment Codes of Good Practice issued on 9 February 2007. The Revised Codes provide for a transitional period ending 30 April 2015. During the transitional period, companies may elect to be measured in terms of the Revised Codes or the 2007 version of the Codes. Companies which are governed by Sector-specific Codes will be measured in terms of those Sector Codes.
- 4.6 As such, Transnet will accept B-BBEE certificates issued based on the Revised Codes. Transnet will also continue to accept B-BBEE certificates issued in terms of the 2007 version of the Codes provided it was issued before 1 May 2015. Thereafter, Transnet will only accept B-BBEE certificates issued based on the Revised Codes.

Respondent's Signature

Date & Company Stamp

- 4.7 In terms of the Revised Codes of Good Practice, Bidders who qualify as QSEs must comply with all the elements of B-BBEE for the purposes of measurement. QSEs that are at least 51% or 100% Black owned are only required to obtain a sworn affidavit on an annual basis confirming that the entity has an Annual Total Revenue of R50 million or less and the entity's Level of Black ownership. Large enterprises must submit their original and valid B-BBEE status level verification certificate or a certified copy thereof, substantiating their B-BBEE rating issued by a Registered Auditor approved by IRBA or a Verification Agency accredited by SANAS.
- 4.8 A trust, consortium or joint venture will qualify for points for its B-BBEE status level as a legal entity, provided that the entity submits its B-BBEE status level certificate.
- 4.9 A trust, consortium or joint venture will qualify for points for their B-BBEE status level as an unincorporated entity, provided that the entity submits their consolidated B-BBEE scorecard as if they were a group structure and that such a consolidated B-BBEE scorecard is prepared for every separate bid.
- 4.10 Tertiary institutions and public entities will be required to submit their B-BBEE status level certificates in terms of the specialised scorecard contained in the B-BBEE Codes of Good Practice.
- 4.11 A person will not be awarded points for B-BBEE status level if it is indicated in the Bid documents that such a Bidder intends subcontracting more than 25% [twenty-five per cent] of the value of the contract to any other enterprise that does not qualify for at least the same number of points that such a Bidder qualifies for, unless the intended subcontractor is an EME that has the capability and ability to execute the subcontract.
- 4.12 A person awarded a contract may not subcontract more than 25% [twenty-five per cent] of the value of the contract to any other enterprise that does not have an equal or higher B-BBEE status level than the person concerned, unless the contract is subcontracted to an EME that has the capability and ability to execute the subcontract.
- 4.13 Bidders are to note that in terms of paragraph 2.6 of Statement 000 of the Revised Codes of Good Practice issued on 11 October 2013 in terms of Government Gazette No. 36928, any representation made by an entity about its B-BBEE compliance must be supported by suitable evidence or documentation. As such, Transnet reserves the right to request such evidence or documentation from Bidders in order to verify any B-BBEE recognition claimed.

## 5. B-BBEE STATUS AND SUBCONTRACTING

- 5.1 **Bidders who claim points in respect of B-BBEE Status Level of Contribution must complete the following:**

B-BBEE Status Level of Contributor \_\_\_\_\_ = \_\_\_\_\_ [maximum of 20 points]

Note: Points claimed in respect of this paragraph 5.1 must be in accordance with the table reflected in paragraph 4.1 above and must be substantiated by means of a B-BBEE certificate issued by a Verification Agency accredited by SANAS or a Registered Auditor approved by IRBA or a sworn affidavit in the case of an EME or QSE.

- 5.2 **Subcontracting:**

Will any portion of the contract be subcontracted? YES/NO [delete which is not applicable]

If YES, indicate:

\_\_\_\_\_  
Respondent's Signature

\_\_\_\_\_  
Date & Company Stamp

- (i) What percentage of the contract will be subcontracted? .....%
- (ii) The name of the subcontractor .....
- (iii) The B-BBEE status level of the subcontractor .....
- (iv) Is the subcontractor an EME? YES/NO

5.3 Declaration with regard to Company/Firm

- (i) Name of Company/Firm.....
- (ii) VAT registration number.....
- (iii) Company registration number.....
- (iv) Type of Company / Firm [TICK APPLICABLE BOX]
  - Partnership/Joint Venture/Consortium
  - One person business/sole propriety
  - Close Corporations
  - Company (Pty) Ltd
- (v) Describe Principal Business Activities
 

.....

.....
- (vi) Company Classification [TICK APPLICABLE BOX]
  - Manufacturer
  - Supplier
  - Professional Service Provider
  - Other Service Providers, e.g Transporter, etc
- (vii) Total number of years the company/firm has been in business.....

PREVIEW COPY

\_\_\_\_\_  
Respondent's Signature

\_\_\_\_\_  
Date & Company Stamp

**BID DECLARATION**

I/we, the undersigned, who warrants that he/she is duly authorised to do so on behalf of the company/firm, certify that points claimed, based on the B-BBEE status level of contribution indicated in paragraph 4 above, qualifies the company/firm for the preference(s) shown and I / we acknowledge that:

- (i) The information furnished is true and correct.
- (ii) In the event of a contract being awarded as a result of points claimed as shown in paragraph 6 above, the contractor may be required to furnish documentary proof to the satisfaction of Transnet that the claims are correct.
- (iii) If the B-BBEE status level of contribution has been claimed or obtained on a fraudulent basis or any of the conditions of contract have not been fulfilled, Transnet may, in addition to any other remedy it may have:
  - (a) disqualify the person from the bidding process;
  - (b) recover costs, losses or damages it has incurred or suffered as a result of that person's conduct;
  - (c) cancel the contract and claim any damages which it has suffered as a result of having to make less favourable arrangements due to such cancellation;
  - (d) restrict the Bidder or contractor, its shareholders and directors, and/or associated entities, or only the shareholders and directors who acted in a fraudulent manner, from obtaining business from Transnet for a period not exceeding 10 years, after the *audi alteram partem* [hear the other side] rule has been applied; and/or
  - (e) forward the matter for criminal prosecution.

**WITNESSES:**

1. ....

2. ....

SIGNATURE OF BIDDER
---------------------

DATE:.....

COMPANY NAME: .....

ADDRESS:.....

PREVIEW COPY

\_\_\_\_\_  
Respondent's Signature

\_\_\_\_\_  
Date & Company Stamp



**Section 6:**

**CERTIFICATE OF ATTENDANCE OF INFORMATION BRIEFING**

It is hereby certified that –

1. \_\_\_\_\_

2. \_\_\_\_\_

Representative(s) of \_\_\_\_\_ *[respondent/Bidder]*

attended the RFQ briefing in respect of the proposed Services to be supplied in terms of this RFQ on \_\_\_\_\_ 2016

\_\_\_\_\_  
TRANSNET'S REPRESENTATIVE

\_\_\_\_\_  
RESPONDENT'S REPRESENTATIVE

DATE \_\_\_\_\_

DATE \_\_\_\_\_

**PREVIEW COPY**

\_\_\_\_\_  
Respondent's Signature

\_\_\_\_\_  
Date & Company Stamp

## Section 7

## CLAUSE BY CLAUSE COMPLIANCE TO PROJECT SPECIFICATION

Please write "yes/comply" for compliance to specification in full in the second column, or if you do not comply write "no/do not comply" in the third column and the fourth column give comment/reasons for non-compliance to non-compliance to clause by clause compliance to Scope of Requirements.

**[Failure to fully complete will result in the Respondents' disqualification.]**

Clause No.	Write in full Yes/comply. (Positive compliance)	Write in full No/ do not comply (Negative compliance)	Reasons / Comments for non-compliance to Project Specification.
<b>1. PROJECT SPECIFICATION</b>			
<b>Scope of work</b>			
<b>14.1 Scope</b>			
Modify the incorrectly pre-ordered anti-vandalism apparatus case lids (1500mm BBF3709) to the required lid specifications (1300mm BBD5575) in order for the lids to correctly fit the required apparatus case boxes installed in the Koedoespoort Depot region under the jurisdiction of the depot engineer, Rail Network Planning Koedoespoort.			
Replace current locking mechanism with new mechanism, standardise the key to be able to unlock any Relay room under Koedoespoort depot. The respondent to take their own measurement on site to quantify all the required material to execute the job			
<b>14.2 Standards</b>			
Unless otherwise specified all material and equipment supplied shall comply with the current edition of the relevant SANS, BS, IEC or Transnet Freight Rail publication where applicable.			
The respondent shall carry out the work in accordance with the Contract Specifications and in a thorough and workmanlike manner. Any sub-standard work shall be rejected and redone			

Respondent's Signature

Date & Company Stamp

Clause No.	Write in full Yes/comply. (Positive compliance)	Write in full No/ do not comply (Negative compliance)	Reasons / Comments for non-compliance to Project Specification.
at the respondents cost.			
The final acceptance of the work rests with Transnet Freight Rail's designated Technical officer.			
The respondent will only work depot normal working hours (Monday to Friday 07:00 till 16:30)			
<b>14.3 Description of work</b>			
Modify the each of the 1500mm (BBF3709) apparatus lids to the exact specifications of a set out for the 1300mm (BBD5575) lid.			
Replace the current locking mechanism with a new mechanism and standardise the keys to ensure that all the relays rooms are using one key.			
<b>14.4 Supply of material</b>			
The 1500mm (BBF3709) apparatus case lids will be supplied by the Koedoespoort Infra Depot personal.			
The Respondent must supply any additional material (that might be required for the installation of apparatus case doors), new locking mechanism for the safety doors, labour and transport and accommodation for the execution of the work.			
<b>14.5 Safety</b>			
The work will be performed under normal operating conditions (i.e. between trains).			
The Respondent will issue all workers employed by him with the necessary protective clothing applicable to the type of work being performed.			
During the execution of the contract, the Respondent will be required to inform the Technical Officer of any staff changes and provide the qualifications of the replacement.			
No open fires will be permitted on site. Any claims arising from the making of such fires will			

Respondent's Signature

Date &amp; Company Stamp

Clause No.	Write in full Yes/comply (Positive compliance)	Write in full No/ do not comply (Negative compliance)	Reasons / Comments for non-compliance to Project Specification.
be for the cost of the respondent.			
The workplace must be cleaned of scrap material (i.e. papers, cable of cuts, tins etc.) after every workday.			
<b>14.6 Respondent's obligation</b>			
The obligation to look after the contract work and everything connected therewith shall rest solely with the Respondent who shall take all necessary precautions to protect the public, the property of the public, the property and personnel of Transnet and all other persons on terrain from injury.			
The Respondent must also protect adjoining properties from trespass or damage during the progress of the work. The Respondent shall also be liable to compensate any person who may suffer damages, recoverable in law, from the Respondent and/or from Transnet, by reason of the said work, and hereby indemnifies Transnet Limited against any claims that may be made by any person whatsoever in respect of any damages or any other losses which may be incurred by such person.			
The respondent must quote us on the rates we are going to use for the duration of the contract in terms of the material, equipment, labour and transport for the execution of the work.			
The rate shall not be changed for the duration of the contract.			
<b>14.7 Handling of work places</b>			
The respondent shall complete the works, including his testing and commissioning within the prescribed time.			
On completion of the work, the Technical officer/Project manager will inspect the works where after the respondent must issue his VAT-invoice within seven days .The respondent shall			

\_\_\_\_\_  
Respondent's Signature

\_\_\_\_\_  
Date & Company Stamp

<b>Clause No.</b>	<b>Write in full Yes/comply. (Positive compliance)</b>	<b>Write in full No/ do not comply (Negative compliance)</b>	<b>Reasons / Comments for non-compliance to Project Specification.</b>
be entitled to receive payment within 30 days from month end statement.			
The commissioning and testing will be done according to specification. The original commissioning sheet will be placed (in an applicable plastic holder) in the apparatus case and a copy thereof will be given to the Technical officer /Project manager.			
The respondent will be liable for any damages to Transnet Freight Rail property or Signal apparatus and it will be repaired and tested by the respondent for his own cost.			
<b>14.8 Site books</b>			
The Respondent will provide a site instruction book on site for the duration of the contract.			
The site instruction book will be used by the Project Manager for issuing instructions to the Respondent as well as a daily diary.			
In the daily dairy the Respondent will record a detailed description of the work done on a daily basis.			
This book will not be removed from the site without the permission of the Project Manager.			
These books become the property of Transnet Freight Rail			

PREVIEW COPY

\_\_\_\_\_  
Respondent's Signature

\_\_\_\_\_  
Date & Company Stamp

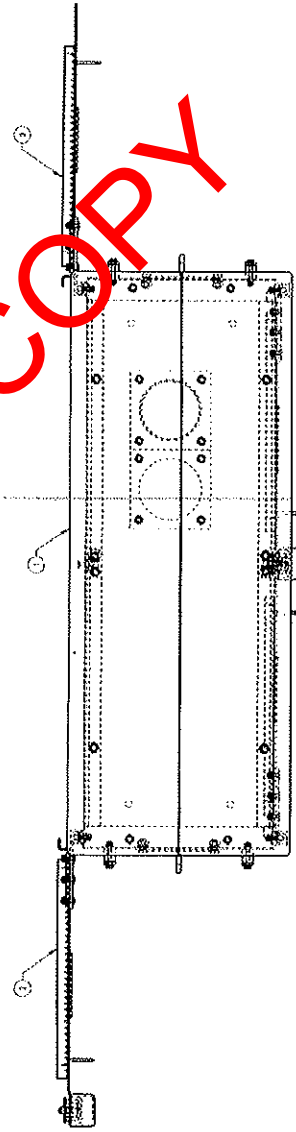
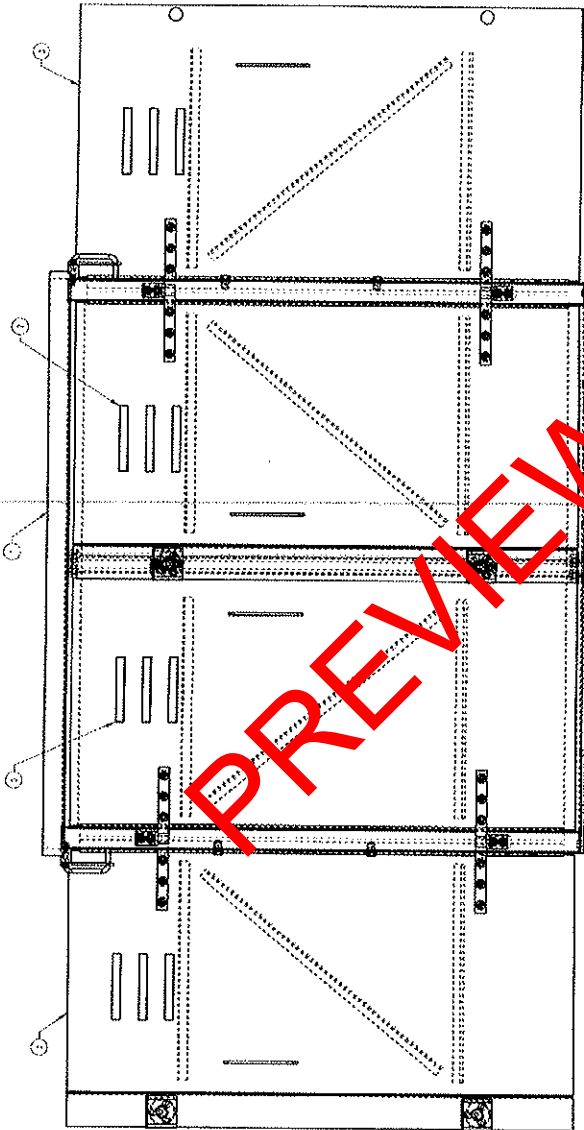
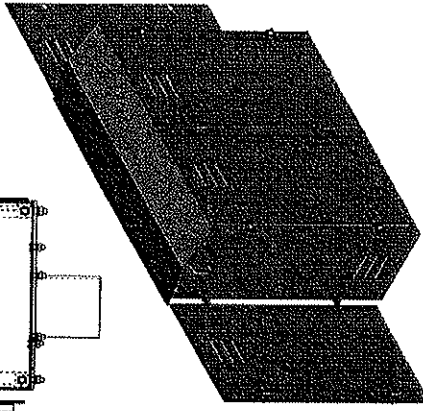
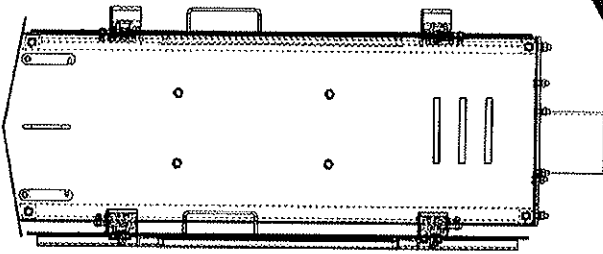

PREVIEW COPY

1	Doc number (Contract)	1	1	1	1
2	Doc number (Part List)	2	2	2	2
3	Doc number (Drawing)	3	3	3	3
DESCRIPTION		QTY	STORAGE ITEM NO	DRAWING NO	
GENERAL ARRANGEMENT 1.3m APPARATUS CASE					

M. DES:	REVISED:
J. APPROVED:	APPROVED:

DR. NO.	DATE	SCALE
REV. NO.	REV. DATE	REV. SCALE
APPROVED:	APPROVED:	APPROVED:

© COPYRIGHT RIGHTS RESERVED BY CENTRAL DRAWING OFFICE  
 DRAWING NO. 1.3m APPARATUS CASE  
 SCALE: 1:1  
 DATE: 14/11/2011  
 REVISED: 14/11/2011  
 APPROVED: 14/11/2011

<b>TRANSNET</b> Engineering 8805575 VERSION 1	

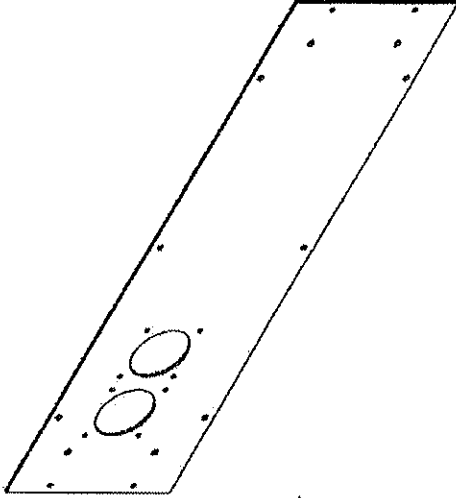

1500mm Apparatus case  
 fitted with TFR, Technology  
 Management approved,  
 anti-vandalism locking  
 mechanism



PREVIEW COPY

Note: MIDDLE HOLES CHANGED TO 12mm

TFR  
 Technology Management  
 Preliminary Approval until 31/12/2012  
 signed:   
 Mr. J.G. Kannemeyer  
 Principal Engineer

SIZE A4	RE: 04	Drawn by:	DWG No: 1500M APP CASE ITEM 23
UNLESS OTHERWISE SPECIFIED: DIMENSIONS ARE IN MM TOLERANCES ARE: FRACTIONS DECIMALS PER-11 HOLE SIZE PER-11		Drawn Date:	Finish: MATERIAL: 6mm A/5
DO NOT SCALE DRAWING SCALE:			SHEET: 1 OF 10

1500mm Apparatus case fitted with TFR, Technology Management approved, anti-vandalism locking mechanism

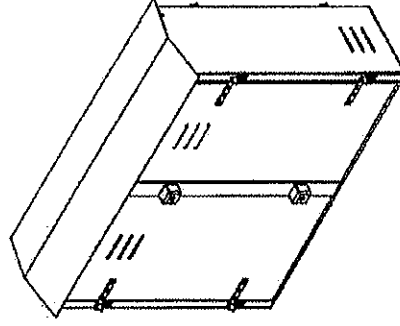
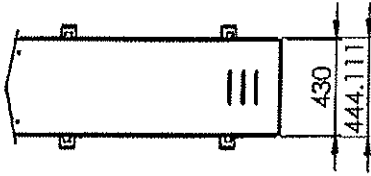
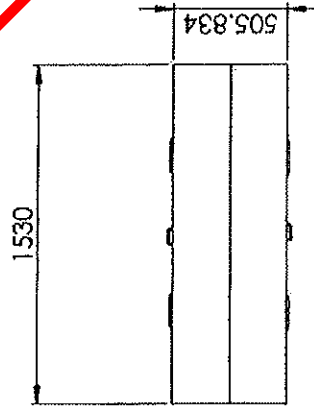
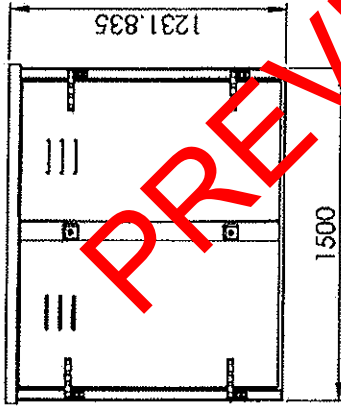

TFR  
Technology Management  
Preliminary Approval until 31/12/2012  
signed:   
Mr. J.G. Kannemeyer  
Principal Engineer

PREVIEW COPY

Note: New Assy

Drawn by:	RE:	SIZE:	DWG No: 1500M APP CASE ASSEM
Drawn Date:	A4	01	
DO NOT SCALE DRAWING	UNLESS OTHERWISE SPECIFIED:		
SCALE:	MATERIALS ARE IN ACCORDANCE WITH THE NATIONAL STANDARD SANS 10130-1:2001		
SHEET: 2 OF 10	Finish: MATERIAL: MIXED MATERIALS		



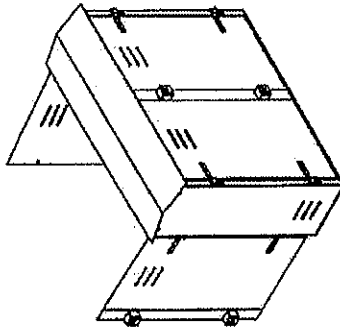
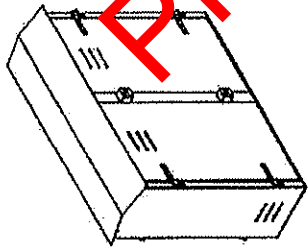

150mm Apparatus case fitted with TFR, Technology Management approved, anti-vandalism locking mechanism

TFR Technology Management  
 Preliminary Approval Infil 3/12/2012  
 signed: *[Signature]*  
 Mr. J. Gannemeyer  
 Principal Engineer

**PREVIEW COPY**

SIZE <b>A4</b>	REV:	Drawn by:	DWG No: 1500M APP CASE ASSEM
	UNLESS OTHERWISE SPECIFIED: DIMENSIONS ARE IN MM TOLERANCES UNLESS OTHERWISE SPECIFIED: FRACTIONS DECIMALS MILLIMETERS	Drawn Date:	FINISH: MATERIAL: MIXED MATERIALS
DO NOT SCALE DRAWING		SHEET: <b>3 OF 10</b>	
SCALE			

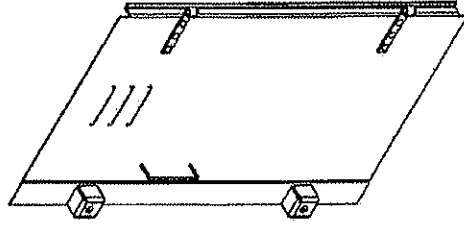
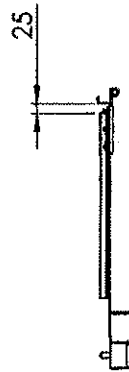
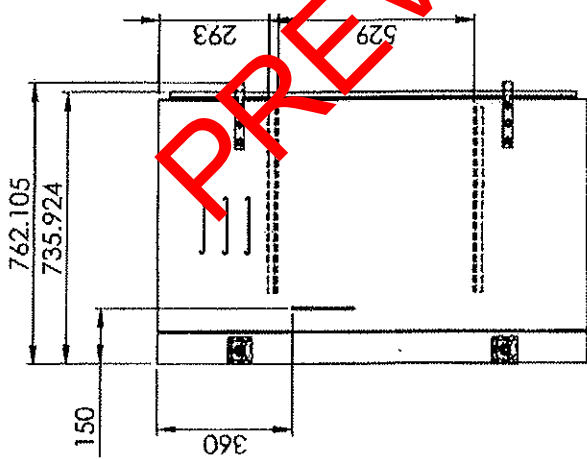

1500mm Apparatus case fitted with TFR, Technology Management approved, anti-vandalism locking mechanism

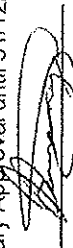
TFR  
Technology Management  
Preliminary Approval until 31/12/2012  
signed:   
Mr. J.G. Kannemeyer  
Principal Engineer

PREVIEW COPY

Notes: HANDLE REVISED & SUPPORTS ADDED

SIZE	RE:	Drawn by:	DWG No:
A4	02		1500M APP RH DOOR ASSEM
UNLESS OTHERWISE SPECIFIED: DIMENSIONS ARE IN MM TOLERANCES ARE: FRACTIONAL DECIMAL MILLIMETRES		Drawn Date:	Finish:
		DO NOT SCALE DRAWING	MATERIAL: Mild Steel Parts
		SCALE:	SHEET:
			4 OF 10

PREVIEW COPY

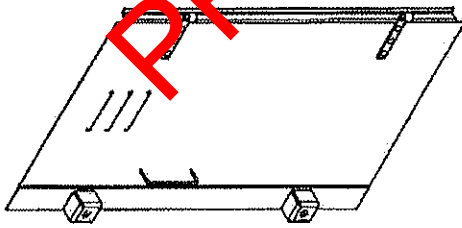

1500mm Apparatus case fitted with TFR, Technology Management approved, anti-vandalism locking mechanism

TFR  
Technology Management  
Preliminary Approval until 31/12/2012  
signed:   
Mr. J.G. Kannemeyer  
Principal Engineer

Note:

DWG No. 1500M APP RH DOOR ASSEM.	
Drawn by:	Drawn Date:
REV: A4 02	DO NOT SCALE DRAWING
UNLESS OTHERWISE SPECIFIED: DIMENSIONS IN MILLIMETERS FRACTIONS TO BE IN 16THS OF AN INCH	SCALE:
SHEET: 5 OF 10	MATERIAL: Mild Steel Parts

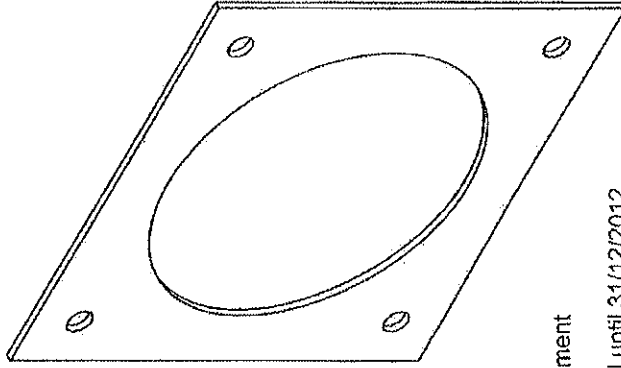
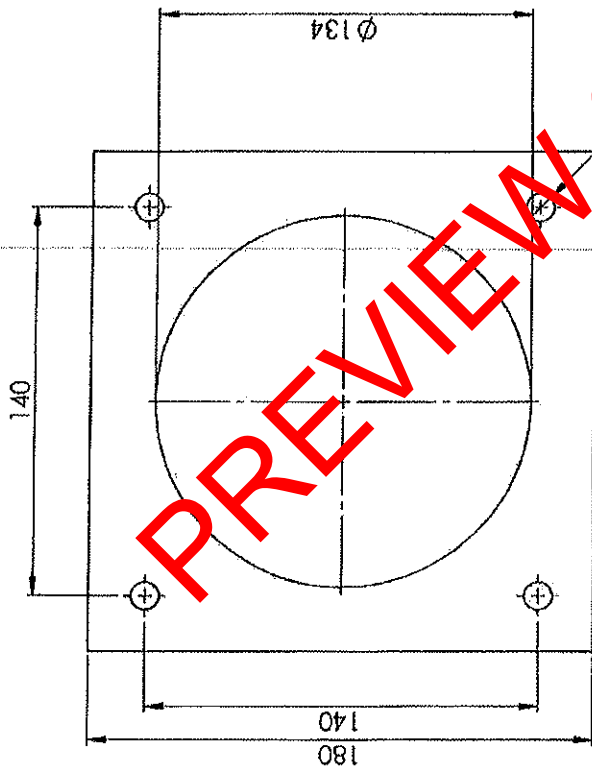

TFR  
Technology Management  
Preliminary Approval until 31/12/2012  
signature

Mr. J. G. Gannemeyer  
Principal Engineer

Note: HOLES REVISED

1500mm Apparatus case fitted with TFR Technology Management approved, anti-vandalism locking mechanism	SIZE	A4	RE:	02	Drawn by:	DWG No: 1500M_APP_CASE_ITEM_24 (ENTRY PLATE)
	UNLESS OTHERWISE SPECIFIED, DIMENSIONS ARE IN MM. TOLERANCES ARE AS FOLLOWS: FINISHES ARE AS SHOWN ON THE DRAWING. THIS DRAWING IS THE PROPERTY OF TFR. IT IS TO BE KEPT IN CONFIDENCE.		SCALE:	1:1	Drawn Date:	Finish:
			SHEET:		6 OF 10	
			MATERIAL:		3mm A/S	

1500mm Apparatus case  
 fitted with TFR, Technology  
 Management approved,  
 anti-vandalism locking  
 mechanism

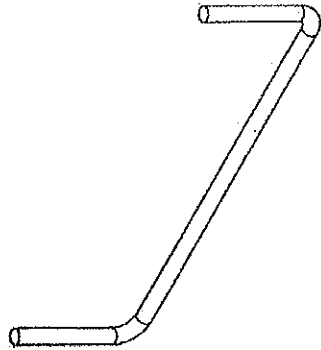
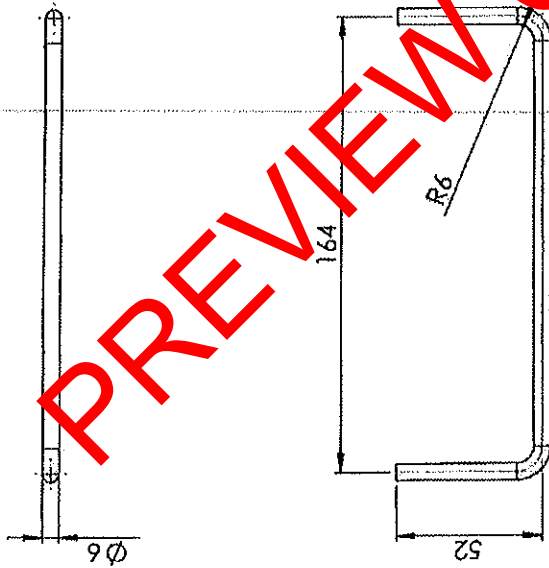

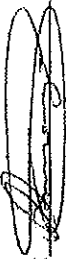

TFR  
 Technology Management  
 Preliminary Approval until 31/12/2012  
 signed:   
 Mr. J.G. Kannemeyer  
 Principal Engineer

PREVIEW COPY

Note: SIZES REVISED

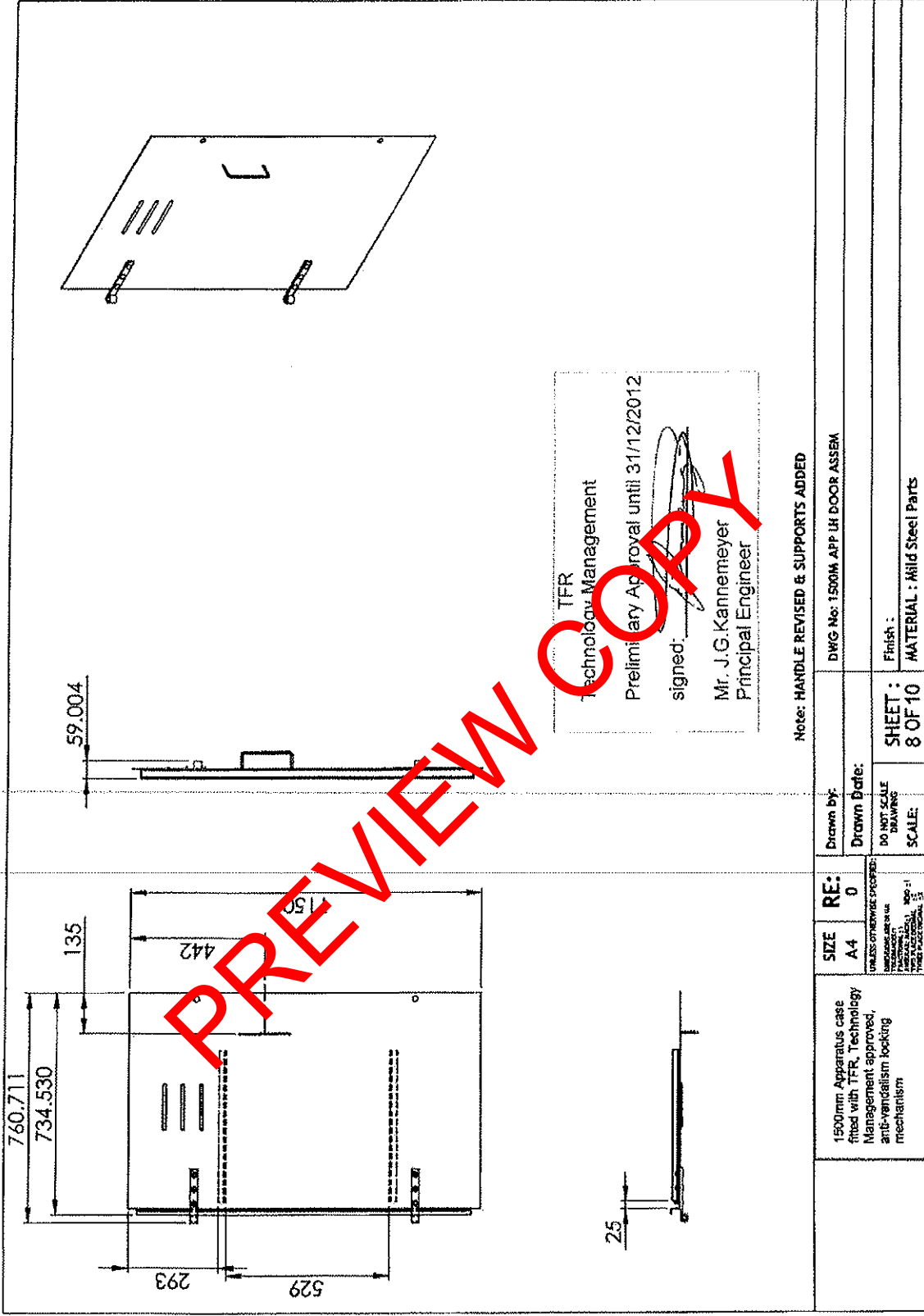
SIZE A4	RE: 02	Drawn by:	DWG No: HANDLE
	Drawn Date:		Finish:
UNLESS OTHERWISE SPECIFIED: DIMENSIONS ARE IN MM. DIMENSIONS TO SURFACE UNLESS SPECIFIED. TOLERANCES: ±0.15		DO NOT SCALE DRAWINGS	MATERIAL: 6mm ROUND BAR
		SCALE:	
		SHEET:	
		7 OF 10	



TFR  
Technology Management  
Preliminary Approval until 31/12/2012  
signed:   
Mr. J.G. Kannemeyer  
Principal Engineer

Note: HANDLE REVISED & SUPPORTS ADDED

PREVIEW COPY

1500mm Apparatus case fitted with TFR, Technology Management approved, anti-vandalism locking mechanism	SIZE	A4	RE:	0	Drawn by:	DWG No: 1500M APP LH DOOR ASSEMB
	UNLESS OTHERWISE SPECIFIED: DIMENSIONS ARE IN MM (FRACTIONS) 1:1000 1:500 1:200 1:100 1:50 1:25 1:10 1:5 1:2 1:1		Drawn Date:		DO NOT SCALE DRAWING	Finish:
					SCALE:	MATERIAL: Mild Steel Parts
						SHEET: 8 OF 10

500

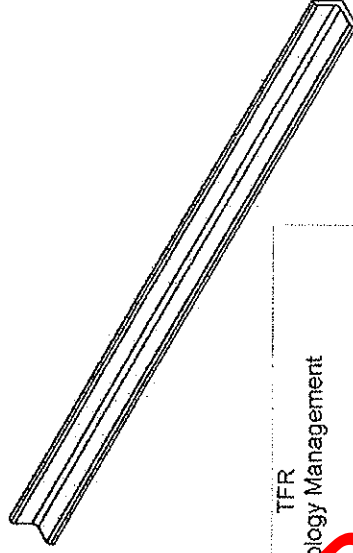
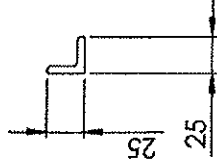

TFR  
Technology Management  
Preliminary Approval until 31/12/2012

signed: 

Mr. J.G. Kannemeyer  
Principal Engineer

Note: New Part

SIZE A4	RE: 01	Drawn by:	DWG No: 1500M APP CASE DOOR SUPPORT
UNLESS OTHERWISE SPECIFIED: DIMENSIONS IN MM TOLERANCES: FRACTIONS DECIMALS ANGLES		Drawn Date:	Finish:
		DO NOT SCALE DRAWING SCALE:	SHEET: 9 OF 10 MATERIAL: 25x25x5mm ANGLE

1500mm Apparatus case  
fitted with TFR, Technology  
Management approved,  
anti-vandalism locking  
mechanism

PREVIEW COPY

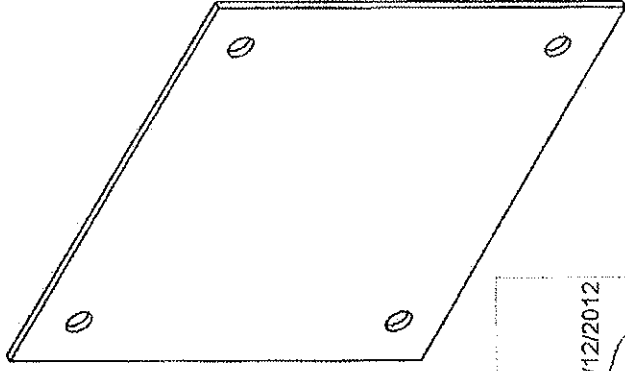
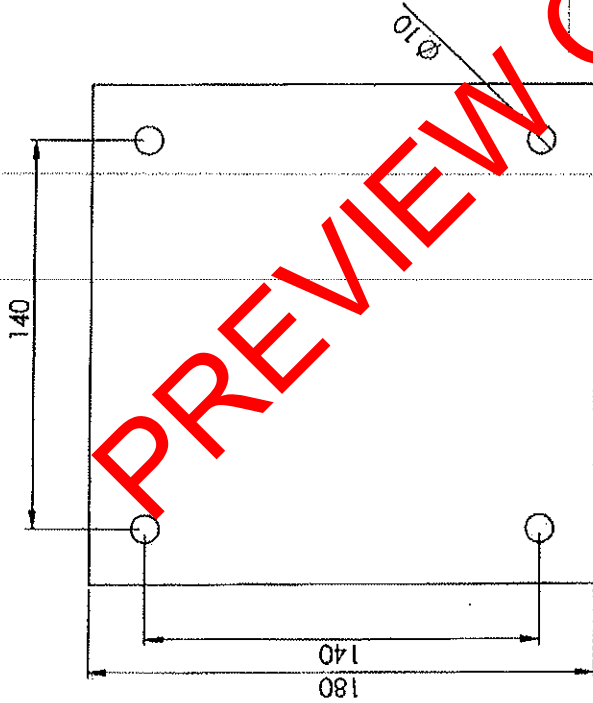

TFR  
Technology Management  
Preliminary Approval until 31/12/2012  
signed: *[Signature]*  
Mr. J.G.Kannemeyer  
Principal Engineer

**PREVIEW COPY**

Note: HOLES REVISED

1500mm Apparatus case fitted with TFR, Technology Management approved, anti-vandalism locking mechanism	SIZE	A4	RE:	02	Drawn by:	DWG No: 1500M APP CASE
	UNLESS OTHERWISE SPECIFIED: DIMENSIONS ARE IN MILLIMETERS DIMENSIONS IN PARENTHESES ARE IN INCHES FINISH AS NOTED OR AS PER STANDARD		SCALE:	DO NOT SCALE DRAWING	Drawn Date:	
						Finish : MATERIAL : 3mm A/S
						SHEET : 10 OF 10