



FREIGHT RAIL, a division of

TRANSNET SOC LTD

Registration Number 1990/000900/30

[hereinafter referred to as **Transnet**]

REQUEST FOR QUOTATION [RFQ] No ERACKT 2290 - 16301

**FOR THE SUPPLY AND DELIVERY OF COMMUNICATION EQUIPMENT (HAND HELD
RADIOS)**

DELIVERY PLACES: PYRAMID SOUTH

ISSUE DATE: 08 JANUARY 2015

CLOSING DATE: 22 JANUARY 2015

CLOSING TIME: 10:00

BID VALIDITY PERIOD: 30 APRIL 2015

"PREVIEW COPY ONLY"

SECTION 1
NOTICE TO BIDDERS

On or after **08 January 2015**, the RFQ documents may be inspected at, and are obtainable from the office of the Transnet Freight Rail Advice Centre, Inyanda House 1, Ground Floor, 21 Wellington Road, Parkton, Johannesburg.

RFQ documents will only be available for collection between 09:00 and 15:00 from **08 January 2015 until 15H00 on Wednesday 21 January 2015**.

Any additional information or clarification will be faxed or emailed to all Respondents, if necessary.

Quotations which must be completed as indicated in Section 2 of this RFQ are to be submitted as follows:

METHOD: Hand delivered
The envelope is to be deposited in the tender box which is located in the foyer on the ground floor and should be addressed as below.

CLOSING DATE AND TIME: **22 January 2015, 10h00**

CLOSING VENUE: The Secretary
Transnet Acquisition Council
Ground floor
Tender box
Inyanda House 1
21 Wellington Road
Parktown
Johannesburg
2001

It should be noted that the tender box is located at the main entrance and is accessible to the public 24 hours a day, 7 days a week

1 Responses to RFQ

Responses to this RFQ [**Quotations**] must not include documents or reference relating to any other quotation or proposal. Any additional conditions must be embodied in an accompanying letter.

2 Broad-Based Black Economic Empowerment [B-BBEE]

Transnet fully endorses and supports the Government's Broad-Based Black Economic Empowerment Programme and it would therefore prefer to do business with local business enterprises who share these same values. Transnet will accordingly allow a "preference" to companies who provide a valid B-BBEE Verification Certificate. All procurement transactions will be evaluated accordingly.

2.1 B-BBEE Scorecard and Rating

As prescribed in terms of the Preferential Procurement Policy Framework Act (PPPFA), Act 5 of 2000 and its Regulations, Respondents are to note that the following preference point systems are applicable to all bids:

- the 80/20 system for requirements with a Rand value of up to R1 000 000 (all applicable taxes included); and
- the 90/10 system for requirements with a Rand value above R1 000 000 (all applicable taxes included).
- Bidders are to note that if the 80/20 preference point system is stipulated in this RFQ and if all Bids received exceed R1 000 000.00, the RFQ must be cancelled.
- The value of this bid is estimated to be below R1 000 000 (all applicable taxes included); and therefore the **80/20** system shall be applicable.

When Transnet invites prospective suppliers to submit Proposals for its various expenditure programmes, it requires Respondents to have their B-BBEE status verified in compliance with the Codes of Good Practice issued in terms of the Broad Based Black Economic Empowerment Act No. 53 of 2003.

The Department of Trade and Industry recently revised the Codes of Good Practice on 11 October 2013 [Government Gazette No. 36928]. The Revised Codes will replace the Black Economic Empowerment Codes of Good Practice issued on 9 February 2007. The Revised Codes provide for a one year transitional period starting 1 October 2013. During the transitional period, companies may elect to be measured in terms of the Revised Codes or the 2007 version of the Codes. After the first year of the implementation of the Revised Codes, B-BBEE compliance will be measured in terms of the Revised Codes without any discretion. Companies which are governed by Sector-specific Codes will be measured in terms of those Sector Codes.

As such, Transnet will accept B-BBEE certificates issued based on the Revised Codes. Transnet will also continue to accept B-BBEE certificates issued in terms of the 2007 version of the Codes provided it was issued before 10 October 2014. Thereafter, Transnet will only accept B-BBEE certificates issued based on the Revised Codes.

Respondents are required to complete Annexure A [the B-BBEE Preference Point Claim Form] and submit it together with proof of their B-BBEE Status as stipulated in the Claim Form in order to obtain preference points for their B-BBEE status.

Note: Failure to submit a valid and original B-BBEE certificate or a certified copy thereof at the Closing Date of this RFQ will result in a score of zero being allocated for B-BBEE.

[Refer clause 19 below for Returnable Documents required]

3 Communication

Respondents are warned that a response will be liable for disqualification should any attempt be made by a Respondent either directly or indirectly to canvass any officer(s) or employee of Transnet in respect of this RFQ between the closing date and the date of the award of the business.

A Respondent may, however, **before the closing date and time**, direct any written enquiries relating to the RFQ to the following Transnet employee:

Name: Kgalalelo Tihabanelo Email: Kgalalelo.Tihabanelo@transnet.net

Respondents may also, at any time **after the closing date** of the RFQ, communicate with the Secretariat of the Transnet Acquisition Council on any matter relating to its RFQ response:

Name: Prudence Nkabinde

Telephone: 011 544 9486

Email: prudence.nkabinde@transnet.net

4 Tax Clearance

The Respondent's original and valid Tax Clearance Certificate must accompany the Quotation. Note that no business shall be awarded to any Respondent whose tax matters have not been declared by SARS to be in order.

5 VAT Registration

The valid VAT registration number must be stated here: _____ [if applicable].

6 Legal Compliance

The successful Respondent shall be in full and complete compliance with any and all applicable national and local laws and regulations.

7 Changes to Quotations

Changes by the Respondent to its submission will not be considered after the closing date and time.

8 Pricing

All prices must be quoted in South African Rand on a fixed price basis, excluding VAT.

9 Prices Subject to Confirmation

Prices quoted which are subject to confirmation will not be considered.

10 Negotiations

Transnet reserves the right to undertake post-tender negotiations with selected Respondents or any number of shortlisted Respondents.

11 Binding Offer

Any Quotation furnished pursuant to this Request shall be deemed to be an offer. Any exceptions to this statement must be clearly and specifically indicated.

12 Disclaimers

Transnet is not committed to any course of action as a result of its issuance of this RFQ and/or its receipt of a Quotation in response to it. Please note that Transnet reserves the right to:

- modify the RFQ's goods / service(s) and request Respondents to re-bid on any changes;
- reject any Quotation which does not conform to instructions and specifications which are detailed herein;
- disqualify Quotations submitted after the stated submission deadline;
- not necessarily accept the lowest priced Quotation;
- reject all Quotations, if it so decides;
- place an order in connection with this Quotation at any time after the RFQ's closing date;
- award only a portion of the proposed goods / service/s which are reflected in the scope of this RFQ;
- split the award of the order/s between more than one Supplier/Service Provider; or
- make no award at all.

Transnet reserves the right to award business to the highest scoring bidder/s unless objective criteria justify the award to another bidder.

Transnet reserves the right to lower the threshold for Technical by 10% [ten percent] if no Bidders pass the predetermined minimum threshold.

13 Transnet's supplier integrity pact

Transnet's Integrity Pact requires a commitment from suppliers and Transnet that they will not engage in any corrupt and fraudulent practices, anti-competitive practices; and act in bad faith towards each other. The Integrity Pact also serves to communicate Transnet's Gift Policy as well as the remedies available to Transnet where a Respondent contravenes any provision of the Integrity Pact.

Respondents are required to familiarise themselves with the contents of the Integrity Pact which is available on the Transnet internet site [www.transnet.net/Tenders/Pages/default.aspx] or on request. Furthermore, Respondents are required to certify that they have acquainted themselves with all the documentation comprising the Transnet Integrity Pact and that they fully comply with all the terms and conditions stipulated in the Transnet Supplier Integrity Pact as follows:

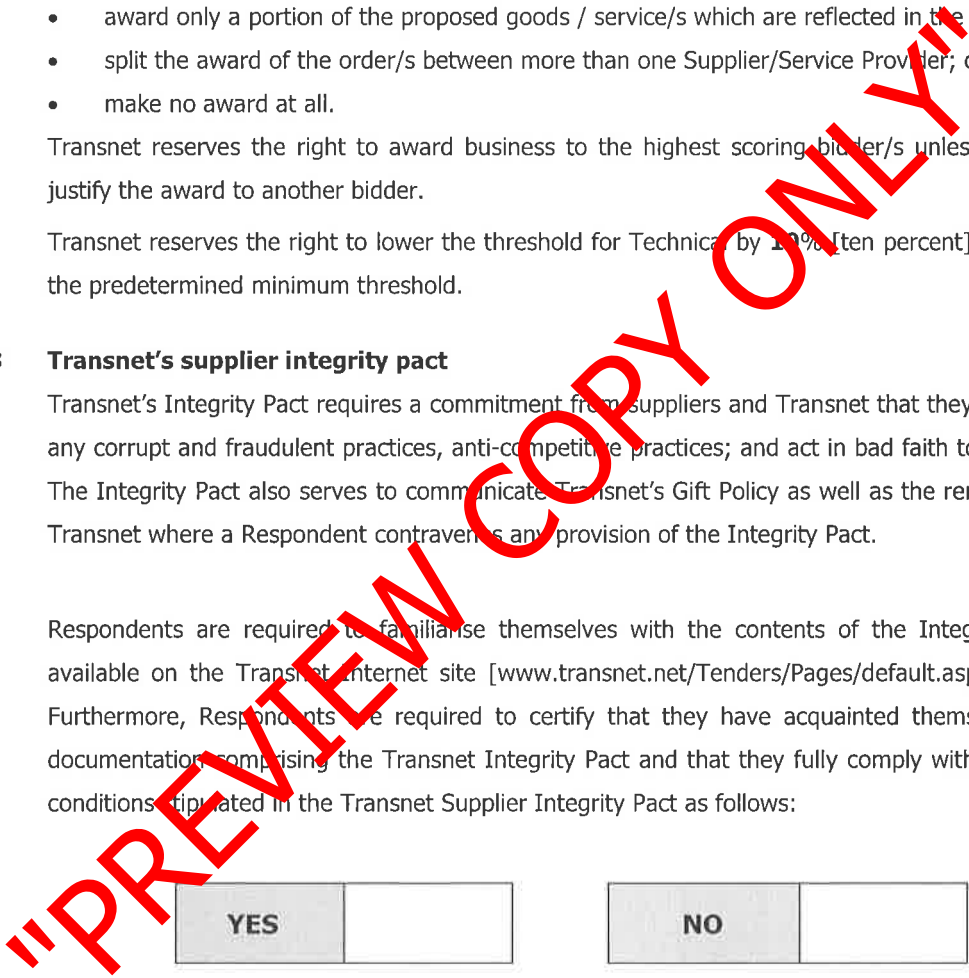

YES	
------------	--

NO	
-----------	--

Should a Respondent need to declare previous transgressions or a serious breach of law in the preceding 5 years as required by Annexure A to the Integrity Pact, such declaration must accompany the Respondent's bid submission.

14 Evaluation Criteria

Transnet will utilise the following criteria [not necessarily in this order] in choosing a Supplier/Service Provider, if so required:

Criterion/Criteria	Explanation
Administrative responsiveness	Completeness of response and mandatory returnable documents
Substantive responsiveness	<p>Prequalification criteria, if any, must be met and whether the Bid materially complies with the scope and/or specification given.</p> <ul style="list-style-type: none"> • A fully completed clause by clause statement of compliance to the project specification. <ul style="list-style-type: none"> ➢ Appendix A: Schedule of Requirements for Handheld Conventional Radio Equipment. ➢ Specification ~ BBG 1946 Version 2.00 ➢ Appendix A: Schedule of Requirements for Handheld Trunked and Conventional Radio Equipment. ➢ Specification ~ B3F 2516 Version 3.00 <p>Note: Failure to complete the above mentioned documents will result in a disqualification for further Evaluation (Price and BBEE).</p>
	<ul style="list-style-type: none"> • Whether the bid contains a priced offer
Functionality Threshold	As prescribed in terms of the Preferential Procurement Policy Framework Act (PPPFA), Act 5 of 2000 and its Regulations, Respondents are to note that functionality is included as threshold with a prescribed percentage threshold of 60%. Compliance to specification and delivery schedule (time frame) will be considered as part of the technical evaluation
Final weighted evaluation based on 80% preference point system as indicated in paragraph 2	<ul style="list-style-type: none"> • Pricing and price basis [firm] - whilst not the sole factor for consideration, competitive pricing and overall level of unconditional discounts¹ will be critical • B-BBEE status of company - Preference points will be awarded to a bidder for attaining the B-BBEE status level of contribution in accordance with the table indicated in Annexure A.

15 Validity Period

Transnet desires a validity period up to 30 April 2015.

This RFQ is valid until _____.

¹ Only unconditional discounts will be taken into account during evaluation. A discount which has been offered conditionally will, despite not being taken into account for evaluation purposes, be implemented when payment is effected.

16 Banking Details

BANK: _____
 BRANCH NAME / CODE: _____
 ACCOUNT HOLDER: _____
 ACCOUNT NUMBER: _____

17 Company Registration

Registration number of company / C.C. _____
 Registered name of company / C.C. _____

18 Disclosure of Prices Quoted

Respondents must indicate here whether Transnet may disclose their quoted prices and conditions to other Respondents:

YES NO

19 Returnable Documents

Returnable Documents means all the documents, Sections and Annexures, as listed in the tables below.

a) Respondents are required to submit with their Quotations the **mandatory Returnable Documents**, as detailed below.

Failure to provide all these Returnable Documents at the Closing Date and time of this RFQ will result in a Respondent's disqualification. Respondents are therefore urged to ensure that all these Documents are returned with their Quotations.

All Sections, as indicated in the footer of each page, must be signed, stamped and dated by the Respondent. Please confirm submission of these mandatory Returnable Documents by so indicating [Yes or No] in the table below:

Mandatory Returnable Documents	Submitted [Yes or No]
SECTION 2 : Quotation Form A fully completed clause by clause statement of compliance to the project specification. > Appendix A: Schedule of Requirements for Handheld Conventional Radio Equipment. > Specification ~ BBG 1946 Version 2.00 > Appendix A: Schedule of Requirements for Handheld Trunked and Conventional Radio Equipment. > Specification ~ BBF 2516 Version 3.00	

b) In addition to the requirements of section (a) above, Respondents are further required to submit with their Quotations the following **essential Returnable Documents** as detailed below.

Failure to provide all these Returnable Documents may result in a Respondent's disqualification. Respondents are therefore urged to ensure that all these documents are returned with their Quotations.

All Sections, as indicated in the footer of each page, must be signed, stamped and dated by the Respondent. Please confirm submission of these essential Returnable Documents by so indicating [Yes or No] in the table below:

Essential Returnable Documents	Submitted [Yes or No]
SECTION 1 : Notice to Bidders	
<ul style="list-style-type: none"> - Valid and original B-BBEE Verification Certificate or certified copy thereof [Large Enterprises and QSEs] Note: failure to provide a valid B-BBEE Verification Certificate at the closing date and time of the RFQ will result in an automatic score of zero for preference 	
<ul style="list-style-type: none"> - Valid and original B-BBEE certificate/sworn affidavit or certified copy thereof from auditor, accounting officer or SANAS accredited verification Agency [EMEs] Note: failure to provide a valid B-BBEE Verification Certificate at the closing date and time of the RFQ will result in an automatic score of zero being allocated for preference 	
<ul style="list-style-type: none"> - In the case of Joint Ventures, a copy of the Joint Venture Agreement or written confirmation of the intention to enter into a Joint Venture Agreement 	
<ul style="list-style-type: none"> - Original valid Tax Clearance Certificate [Consortia / Joint Ventures must submit a separate Tax Clearance Certificate for each party] 	
SECTION 3 : Standard Terms and Conditions of Contract for the Supply of Services to Transnet	
SECTION 4 : Vendor Application Form	
<ul style="list-style-type: none"> - Original cancelled cheque or bank verification of banking details 	
<ul style="list-style-type: none"> - Certified copies of IDs of shareholder/directors/members [as applicable] 	
<ul style="list-style-type: none"> - Certified copies of the relevant company registration documents from Companies and Intellectual Property Commission (CIPC) 	
<ul style="list-style-type: none"> - Certified copies of the company's shareholding/director's portfolio 	
<ul style="list-style-type: none"> - Entry's letterhead 	
<ul style="list-style-type: none"> - Certified copy of VAT Registration Certificate [RSA entities only] 	
<ul style="list-style-type: none"> - Certified copy of valid Company Registration Certificate [if applicable] 	
<ul style="list-style-type: none"> - A signed letter from Respondent's auditor or accountant confirming most recent annual turnover figures 	
SECTION 5 : B-BBB Preference Points Claim Form	
SECTION 6 : Non-disclosure agreement (NDA)	

SECTION 2 QUOTATION FORM

I/We _____
hereby offer to supply the goods/services at the prices quoted in the Price Schedule below, in accordance with the conditions related thereto.

I/We agree to be bound by those terms and conditions in:

- the Standard Terms and Conditions for the Supply of Goods or Services to Transnet [Section 3 hereof]; and
- any other standard or special conditions mentioned and/or embodied in this Request for Quotation.

I/We accept that unless Transnet should otherwise decide and so inform me/us, this Quotation [and, if any, its covering letter and any subsequent exchange of correspondence], together with Transnet's acceptance thereof shall constitute a binding contract between Transnet and me/us.

I/We further agree that if, after I/we have been notified of the acceptance of my/our Quotation, I/we fail to deliver the said goods/service/s within the delivery lead-time quoted, Transnet may, without prejudice to any other legal remedy which it may have, cancel the order and recover from me/us any expenses incurred by Transnet in calling for Quotations afresh and/or having to accept any less favourable offer.

Price Schedule

[Please complete Appendix A, B & C of the attached Schedule of Requirements for Handheld Trunked and Conventional Radio Equipment]

Lead-Time from date of purchase order: _____ [days/weeks]

Notes to Pricing:

- a) All Prices must be quoted in South African Rand, exclusive of VAT
- b) To facilitate like-for-like comparison bidders must submit pricing strictly in accordance with this price schedule and not utilise a different format. Deviation from this pricing schedule could result in a bid being disqualified.
- c) Please note that should you have offered a discounted price(s), Transnet will only consider such price discount(s) in the final evaluation stage if offered on an unconditional basis.

Technical Enquiries:

Contact person: Prem Naicker
Tel. (012) 315 3410
Cell. 083 460 5897

SECTION 3**STANDARD TERMS AND CONDITIONS FOR THE SUPPLY OF GOODS OR SERVICES TO TRANSNET**

A Supplier/Service Provider shall be obliged to adhere to the Standard Terms and Conditions for the Supply of Goods and Services to Transnet as expressed hereunder. Should the Respondent find any condition(s) unacceptable, it should indicate which condition(s) is/are unacceptable and offer an alternative(s). A Quotation submitted by a Respondent will be subjected to review and acceptance or rejection of its proposed contractual terms and conditions by Transnet's Legal Counsel, prior to consideration for an award of business.

1 SOLE AGREEMENT

Unless otherwise agreed in writing, these terms [Terms and each Term] and Transnet's purchase order(s) [Order or Orders] represent the only conditions upon which Transnet SOC Ltd [Transnet] procures goods [the Goods] or services [the Services] specified in the Order from the person to whom the Order is addressed [the Supplier/Service Provider]. Transnet does not accept any other conditions which the Supplier/Service Provider may specify, unless otherwise agreed to by Transnet in writing. In the event of any inconsistency between these Terms and any Order, these Terms shall take precedence.

2 CONFORMITY WITH ORDER

Goods/Services shall conform strictly with the Order. The Supplier/Service Provider shall not vary the quantities specified and/or the specification, or any stipulated in the Order, without the prior written consent of Transnet. The Supplier/Service Provider warrants that the Goods/Services shall be fit for their purpose and of satisfactory quality.

3 DELIVERY AND TITLE

3.1 The delivery dates and addresses are those in the Order. Time shall be of the essence in respect of the Supplier's/Service Provider's obligations under the Order.

3.2 The Supplier/Service Provider will not be excused for delay in delivery or performance except due to circumstances outside its control and then only subject to the Supplier/Service Provider having notified Transnet in writing on becoming aware of such circumstances. Transnet may terminate an Order, in whole or in part, without incurring any liability to the Supplier/Service Provider if such a delay becomes, in Transnet's absolute opinion, significant.

3.3 If on delivery, the Goods/Services do not conform to the Order, Transnet may reject the Goods/Services and the Supplier/Service Provider shall promptly rectify any defects or in Transnet's opinion, supply appropriate replacement Goods/Services at the Supplier's/Service Provider's expense within the specified delivery times, without any liability due by Transnet.

4 PRICE AND PAYMENT

4.1 Prices specified in an Order cannot be increased. Payment for the Goods/Services shall be made by Transnet against an original undisputed invoice(s) [a Tax Invoice], supporting documentation and month-end statement from the Supplier/Service Provider. Tax Invoices plus supporting documentation shall be posted to the address shown in the Order.

4.2 Payment of the Supplier's/Service Provider's valid Tax Invoice(s) will be made by Transnet in the South African currency and on the terms stated in the Order, the standard payment terms being 30 [thirty] days from date of receipt by Transnet of a month-end statement, unless otherwise agreed to in writing. Transnet shall arrange for payment of such Tax Invoices and any pre-authorised additional expenses incurred, provided that the authorised expenses are supported by acceptable documentary proof of expenditure incurred [where this is available]. Any amounts due in terms of these Terms shall be paid to the Supplier/Service Provider, taking into account any deduction or set-off and bank charges.

5 PROPRIETARY RIGHTS LIABILITY

If any allegations should be made or any claim asserted against Transnet that ownership of, or any act or omission by Transnet in relation to Goods/Services or any written material provided to Transnet relating to any Goods/Services or pursuant to an Order being a violation or infringement of any third party's contractual, industrial, commercial or intellectual property rights including but not limited to any patent, registered design, design right, trade mark, copyright or service mark or any application thereof, the Supplier/Service Provider hereby indemnifies Transnet against and holds Transnet harmless from any and all losses, liabilities, costs, claims, damages and expenses [including any legal fees] arising directly or indirectly from such allegation or claim provided that this indemnity shall not apply where the allegation or claim arises solely as a result of the Supplier/Service Provider following a design or process originated and furnished by Transnet. The Supplier/Service Provider shall either

- a) procure for Transnet the right to continue using the infringing Goods; or
- b) modify or replace the Goods/Services so that they become non-infringing,

provided that in both cases the Goods/Services shall continue to meet Transnet's requirements and any specifications stipulated in the Order. Should neither option be possible, the Supplier/Service Provider may remove, with Transnet's prior written consent, such Goods/Services and will pay to Transnet a sum equivalent to the purchase price. If Transnet refuses to give such consent, the Supplier/Service Provider shall have no liability in respect of any continued use of the infringing Goods/Services after Supplier's/Service Provider's prior written request to remove the same.

6 PROPRIETARY INFORMATION

All information which Transnet has divulged or may divulge to the Supplier/Service Provider and any information relating to Transnet's business which may have come into the Supplier's/Service Provider's possession whilst carrying out an Order, and the existence of the Order, shall be treated by the Supplier/Service Provider as confidential information and shall not, without Transnet's prior written consent, be disclosed to any third party, or be used or copied for any purposes other than to perform the Order. This clause does not apply to information which is public knowledge or available from other sources other than by breach of this Term. Upon request by Transnet, the Supplier/Service Provider shall return all materials issued pursuant to the Order and, pending this, shall protect Transnet's rights in any such materials. Such confidential information shall at all material times be the property of Transnet.

7 PUBLICITY

The Supplier/Service Provider shall not name Transnet or use its trademarks, service marks [whether registered or not] or Goods in connection with any publicity without Transnet's prior written consent.

8 TERMINATION OF ORDER

- 8.1 Transnet may cancel an Order in whole or in part at any time upon at least 7 [seven] days' written notice to the Supplier/Service Provider, or when there is a change in control of the Supplier/Service Provider or the Supplier/Service Provider commits any serious breach or any repeated or continued material breach of its obligations under these Terms and/or Order or shall have been guilty of conduct tending to bring itself into disrepute, on written notice to the Supplier/Service Provider when such work on the Order shall stop.
- 8.2 Transnet shall pay the Supplier/Service Provider a fair and reasonable price for justified work in progress, where such price reflects only those costs not otherwise recoverable by the Supplier/Service Provider, at the time of termination, and the Supplier/Service Provider shall give Transnet full assistance to check the extent of such work in progress. Payment of such price shall be in full and final satisfaction of any claims arising out of such termination and upon such payment the Supplier/Service Provider shall deliver to Transnet all work, including any materials, completed or in progress. The sum payable to the Supplier/Service Provider under this clause will not in any event exceed the total amount that would have been payable to the Supplier/Service Provider had the Order not been terminated.
- 8.3 In the event of termination the Supplier/Service Provider must submit all claims within 2 [two] months of termination after which time claims will only be met in what Transnet considers exceptional circumstances.
- 8.4 If the Goods or Services are not provided in accordance with an Order, the Order shall be deemed terminated and the Supplier/Service Provider shall compensate Transnet for any costs incurred in obtaining substitute goods or any damage caused due to the failure or delay in the delivery.

9 ACCESS

The Supplier/Service Provider shall be liable for the acts, omissions and defaults of its personnel or agents who, for the purposes of the Order, shall be treated as if they are the Supplier's/Service Provider's employees. The Supplier/Service Provider shall ensure that any such personnel or agents, whilst on Transnet's premises, shall comply with Transnet's health and safety, security and system security rules and procedures as and where required.

10 WARRANTY

The Supplier/Service Provider warrants that it is competent to supply the Goods/Services in accordance with these Terms to the reasonable satisfaction of Transnet and that all Goods/Services delivered under the Order: (a) conform and comply in all relevant legislation, standards, directives and orders related to [inter alia] the Goods/Services in force at the time of delivery, and to any specifications referred to in the Order; (b) will not cause any deterioration in the functionality of any Transnet equipment; and (c) do not infringe any third party rights of any kind. The Supplier/Service Provider hereby indemnifies Transnet against all losses, liabilities, costs, claims, damages, expenses and awards of any kinds incurred or made against Transnet in connection with any breach of this warranty.

11 INSOLVENCY

If the Supplier/Service Provider shall have a receiver, manager, administrator, liquidator or like person appointed over all or any part of its assets or if the Supplier/Service Provider compounds with its creditors or passes a resolution for the winding up or administration of the Supplier/Service Provider, Transnet is at liberty to terminate the Order or Orders forthwith, or at its option, to seek performance by any such appointed person.

12 ASSIGNMENT

The Supplier/Service Provider shall not assign its obligations under an Order without Transnet's prior written consent, which consent shall not be unreasonably withheld or delayed.

13 NOTICES

Notices under these Terms shall be delivered by hand to the relevant addresses of the parties in the Order or may be served by facsimile or by email, in which event notice shall be deemed served on acknowledgement of receipt by the recipient.

14 LAW

Orders shall be governed by and interpreted in accordance with South African law and any disputes arising herein shall be subject to South African arbitration under the rules of the Arbitration Foundation of South Africa, which rules are deemed incorporated by reference in this clause. The reference to arbitration shall not prevent Transnet referring the matter to any South African courts, having jurisdiction, to which the Supplier/Service Provider hereby irrevocably submits, but without prejudice to Transnet's right to take proceedings against the Supplier/Service Provider in other jurisdictions and/or obtaining interim relief on an urgent basis from a court of competent jurisdiction pending the decision in other courts or from instituting in any court of competent jurisdiction any proceedings for an interdict or any other injunctive relief. If the Supplier/Service Provider does not have a registered office in the South Africa it will at all times maintain an agent for service of process in South Africa and shall give Transnet the name and address of such agent as such may be amended, in writing, from time to time.

15 GENERAL

Completion or termination of an Order shall be without prejudice to any Term herein which by its nature would be deemed to continue after completion or termination, including but not limited to clauses **Error! Reference source not found., Error! Reference source not found., 7 and Error! Reference source not found..** Headings are included herein for convenience only. If any Term herein be held illegal or unenforceable, the validity or enforceability of the remaining Terms shall not be affected. No failure or delay by Transnet to enforce any rights under these Terms will operate as a waiver thereof by Transnet. All rights and remedies available to either party under these Terms shall be in addition to, not to the exclusion of, rights otherwise available at law.

16 COUNTERPARTS

These Terms and conditions may be signed in any number of counterparts, all of which taken together shall constitute one and the same instrument. Any party may enter into this agreement by signing any such counterpart.

By signing this RFQ document, the Respondent is deemed to acknowledge that he/she has made himself/herself thoroughly familiar with all the conditions governing this RFQ, including those contained in any printed form stated to form part hereof and Transnet SOC Ltd will recognise no claim for relief based on an allegation that the Respondent overlooked any such condition or failed to properly take it into account for the purpose of calculating quoted prices or otherwise.

SIGNED at _____ on this _____ day of _____ 20____

.....
SIGNATURE OF RESPONDENT'S AUTHORISED REPRESENTATIVE

NAME: _____

DESIGNATION: _____

REGISTERED NAME OF COMPANY: _____

PHYSICAL ADDRESS:

Respondent's contact person: *[Please complete]*

Name	:	
Designation	:	
Telephone	:	
Cell Phone	:	
Facsimile	:	
Email	:	
Website	:	

"PREVIEW COPY ONLY"

Transnet urges its clients, suppliers and the general public to report any fraud or corruption to TIP-OFFS ANONYMOUS : 0800 003 056

Respondent's Signature

Date & Company Stamp

**SECTION 4
VENDOR APPLICATION FORM**

Respondents are to furnish the following documentation and complete the Vendor Application Form below:

1. **Original** cancelled cheque **OR** letter from the Respondent’s bank verifying banking details [with bank stamp]
2. **Certified** copy of Identity Document(s) of Shareholders/Directors/Members [where applicable]
3. **Certified copies** of the relevant company registration documents from Companies and Intellectual Property Commission (CIPC)
4. **Certified copies** of the company’s shareholding/director’s portfolio
5. A letter on the company’s letterhead confirm physical and postal addresses
6. **Original** valid SARS Tax Clearance Certificate
7. **Certified copy** of VAT Registration Certificate
8. **A valid and original** B-BBEE Verification Certificate / sworn affidavit **or certified copy** thereof meeting the requirements for B-BBEE compliance as per the B-BBEE Codes of Good Practice
9. **Certified copy** of valid Company Registration Certificate [if applicable]

Vendor Application Form

Note: *No contract shall be awarded to any South African Respondent whose tax matters have not been declared by SARS to be in order.*

Company Trading Name						
Company Registered Name						
Company Registration Number Or ID Number If A Sole Proprietor						
Form of entity	CC	Trust	Pty Ltd	Limited	Partnership	Sole Proprietor
VAT number (if registered)						
Company Telephone Number						
Company Fax Number						
Company E-Mail Address						
Company Website Address						
Bank Name				Bank Account Number		

Respondent’s Signature

Date & Company Stamp

Postal Address				Code	
Physical Address				Code	
Contact Person					
Designation					
Telephone					
Email					
Annual Turnover Range (Last Financial Year)	< R5 Million		R5-35 million		> R35 million
Does Your Company Provide	Products		Services		Both
Area Of Delivery	National		Provincial		Local
Is Your Company A Public Or Private Entity			Public		Private
Does Your Company Have A Tax Directive Or IRP30 Certificate			Yes		No
Main Product Or Service Supplied (E.G.: Stationery/Consulting)					

BEE Ownership Details					
% Black Ownership		% Black women ownership		% Disabled person/s ownership	
Does your company have a BEE certificate			Yes	No	
What is your broad based BEE status (Level 1 to 9 / Unknown)					
How many personnel does the firm employ			Permanent	Part time	

Transnet Contact Person	
Contact number	
Transnet operating division	

Duly Authorised To Sign For And On Behalf Of Firm / Organisation			
Name		Designation	
Signature		Date	

Stamp And Signature Of Commissioner Of Oath			
Name		Date	
Signature		Telephone No.	

SECTION 5

B-BBEE PREFERENCE POINTS CLAIM FORM

This preference form contains general information and serves as a claim for preference points for Broad-Based Black Economic Empowerment [**B-BBEE**] Status Level of Contribution.

1. INTRODUCTION

- 1.1.1 A total of 10 preference points shall be awarded for B-BBEE Status Level of Contribution.
- 1.1.2 Failure on the part of a Bidder to fill in and/or to sign this form and submit a B-BBEE Verification Certificate from a Verification Agency accredited by the South African Accreditation System [**SANAS**] or a Registered Auditor approved by the Independent Regulatory Board of Auditors [**IRBA**] or an Accounting Officer as contemplated in the Close Corporation Act [**CCA**] together with the bid will be interpreted to mean that preference points for B-BBEE Status Level of Contribution are not claimed.
- 1.1.3 Transnet reserves the right to require of a Bidder, either before a bid is adjudicated or at any time subsequently, to substantiate any claim in regard to preferences, in any manner required by Transnet.

2. GENERAL DEFINITIONS

- 2.1.1 "**all applicable taxes**" include value-added tax, pay as you earn, income tax, unemployment insurance fund contributions and skills development levies;
- 2.1.2 "**B-BBEE**" means broad-based black economic empowerment as defined in section 1 of the Broad-Based Black Economic Empowerment Act;
- 2.1.3 "**B-BBEE status of contributor**" means the B-BBEE status received by a measured entity based on its overall performance using the relevant scorecard contained in the Codes of Good Practice on Black Economic Empowerment, issued in terms of section 9(1) of the Broad-Based Black Economic Empowerment Act;
- 2.1.4 "**Bid**" means a written offer in a prescribed or stipulated form in response to an invitation by Transnet for the provision of goods, works or services;
- 2.1.5 "**Broad-Based Black Economic Empowerment Act**" means the Broad-Based Black Economic Empowerment Act, 2003 [Act No. 53 of 2003];
- 2.1.6 "**comparative price**" means the price after the factors of a non-firm price and all unconditional discounts that can be utilised have been taken into consideration;
- 2.1.7 "**consortium or joint venture**" means an association of persons for the purpose of combining their expertise, property, capital, efforts, skills and knowledge in an activity for the execution of a contract;
- 2.1.8 "**contract**" means the agreement that results from the acceptance of a bid by Transnet;
- 2.1.9 "**EME**" means any enterprise with an annual total revenue of R5 [five] million or less as per the 2007 version of the B-BBEE Codes of Good Practice and means any enterprise with an annual total revenue of R10 [ten] million or less as per the Revised Codes of Good Practice issued on 11 October 2013 in terms of Government Gazette No. 36928;
- 2.1.10 "**firm price**" means the price that is only subject to adjustments in accordance with the actual

increase or decrease resulting from the change, imposition, or abolition of customs and excise duty and any other duty, levy, or tax, which, in terms of the law or regulation, is binding on the contractor and demonstrably has an influence on the price of any supplies, or the rendering costs of any service, for the execution of the contract;

- 2.1.11 **"functionality"** means the measurement according to predetermined norms, as set out in the bid documents, of a service or commodity that is designed to be practical and useful, working or operating, taking into account, among other factors, the quality, reliability, viability and durability of a service and the technical capacity and ability of a bidder;
- 2.1.12 **"non-firm prices"** means all prices other than "firm" prices;
- 2.1.13 **"QSE"** means any enterprise with an annual total revenue between R5 [five] million and R35 [thirty five] million as per the 2007 version of the B-BBEE Codes of Good Practice and means any enterprise with an annual total revenue of between R10 [ten] million and R50 [fifty] million as per the Revised Codes of Good Practice issued on 11 October 2013 in terms of Government Gazette No. 36928;
- 2.1.14 **"person"** includes reference to a juristic person;
- 2.1.15 **"rand value"** means the total estimated value of a contract in South African currency, calculated at the time of bid invitations, and includes all applicable taxes and excise duties;
- 2.1.16 **"subcontract"** means the primary contractor's assigning or leasing or making out work to, or employing another person to support such primary contractor in the execution of part of a project in terms of the contract;
- 2.1.17 **"total revenue"** bears the same meaning assigned to this expression in the Codes of Good Practice on Black Economic Empowerment, issued in terms of section 9(1) of the Broad-Based Black Empowerment Act and promulgated in the Government Gazette on 9 February 2007;
- 2.1.18 **"trust"** means the arrangement through which the property of one person is made over or bequeathed to a trustee to administer such property for the benefit of another person; and
- 2.1.19 **"trustee"** means any person, including the founder of a trust, to whom property is bequeathed in order for such property to be administered for the benefit of another person.

3. ADJUDICATION USING A POINT SYSTEM

- 3.1.1 The Bidder obtaining the highest number of total points for the evaluation criteria as enumerated in Section 2 of the RFQ will be awarded the contract, unless objective criteria justifies the award to another bidder.
- 3.1.2 Preference points shall be calculated after prices have been brought to a comparative basis taking into account all factors of non-firm prices and all unconditional discounts.
- 3.1.3 Points scored will be rounded off to 2 [two] decimal places.
- 3.1.4 In the event of equal points scored, the Bid will be awarded to the Bidder scoring the highest number of preference points for B-BBEE.
- 3.1.5 However, when functionality is part of the evaluation process and two or more Bids have scored equal points including equal preference points for B-BBEE, the successful Bid will be the one scoring the highest score for functionality.
- 3.1.6 Should two or more Bids be equal in all respect, the award shall be decided by the drawing of lots.

4. POINTS AWARDED FOR B-BBEE STATUS LEVEL OF CONTRIBUTION

4.1.1 In terms of the Preferential Procurement Regulations, 2011, preference points shall be awarded to a Bidder for attaining the B-BBEE status level of contribution in accordance with the table below:

B-BBEE Status Level of Contributor	Number of Points [Maximum 20]
1	20
2	18
3	16
4	12
5	8
6	6
7	4
8	2
Non-compliant contributor	0

- 4.1.2 Bidders who qualify as EMEs in terms of the 2007 version of the Codes of Good Practice must submit a certificate issued by an Accounting Officer as contemplated in the CCA or a Verification Agency accredited by SANAS or a Registered Auditor. Registered auditors do not need to meet the prerequisite for IRBA's approval for the purpose of conducting verification and issuing EME's with B-BBEE Status Level Certificates.
- 4.1.3 Bidders who qualify as EMEs in terms of the Revised Codes of Good Practice issued on 11 October 2013 in terms of Government Gazette No. 36928 are only required to obtain a sworn affidavit on an annual basis confirming that the entity has an Annual Total Revenue of R10 million or less and the entity's Level of Black ownership.
- 4.1.4 In terms of the 2007 version of the Codes of Good Practice, Bidders other than EMEs must submit their original and valid B-BBEE status level verification certificate or a certified copy thereof, substantiating their B-BBEE rating issued by a Registered Auditor approved by IRBA or a Verification Agency accredited by SANAS.
- 4.1.5 In terms of the Revised Codes of Good Practice issued on 11 October 2013 in terms of Government Gazette No. 36928, Bidders who qualify as QSEs are only required to obtain a sworn affidavit on an annual basis confirming that the entity has an Annual Total Revenue of R50 million or less and the entity's Level of Black ownership. Large enterprises must submit their original and valid B-BBEE status level verification certificate or a certified copy thereof, substantiating their B-BBEE rating issued by a Registered Auditor approved by IRBA or a Verification Agency accredited by SANAS.
- 4.1.6 A trust, consortium or joint venture will qualify for points for its B-BBEE status level as a legal entity, provided that the entity submits its B-BBEE status level certificate.
- 4.1.7 A trust, consortium or joint venture will qualify for points for their B-BBEE status level as an unincorporated entity, provided that the entity submits their consolidated B-BBEE scorecard as if they were a group structure and that such a consolidated B-BBEE scorecard is prepared for every separate bid.

- 4.1.8 Tertiary institutions and public entities will be required to submit their B-BBEE status level certificates in terms of the specialised scorecard contained in the B-BBEE Codes of Good Practice.
- 4.1.9 A person will not be awarded points for B-BBEE status level if it is indicated in the Bid documents that such a Bidder intends subcontracting more than 25% [twenty-five per cent] of the value of the contract to any other enterprise that does not qualify for at least the same number of points that such a Bidder qualifies for, unless the intended subcontractor is an EME that has the capability and ability to execute the subcontract.
- 4.1.10 A person awarded a contract may not subcontract more than 25% [twenty-five per cent] of the value of the contract to any other enterprise that does not have an equal or higher B-BBEE status level than the person concerned, unless the contract is subcontracted to an EME that has the capability and ability to execute the subcontract.
- 4.1.11 Bidders are to note that in terms of paragraph 2.6 of Statement 000 of the Revised Codes of Good Practice issued on 11 October 2013 in terms of Government Gazette No. 36928, any representation made by an entity about its B-BBEE compliance must be supported by suitable evidence or documentation. As such, Transnet reserves the right to request such evidence or documentation from Bidders in order to verify any B-BBEE recognition claimed.

5. B-BBEE STATUS AND SUBCONTRACTING

5.1.1 Bidders who claim points in respect of B-BBEE Status Level of Contribution must complete the following:

B-BBEE Status Level of Contribution _____ = _____ [maximum of 20 points]

Note: Points claimed in respect of this paragraph 5.1 must be in accordance with the table reflected in paragraph 4.1 above and must be substantiated by means of a B-BBEE certificate issued by a Verification Agency accredited by SANAS or a Registered Auditor approved by IRBA or sworn affidavit in the case of an EME or QSE.

5.1.2 Subcontracting:

Will any portion of the contract be subcontracted? YES/NO [delete which is not applicable]

If YES, indicate:

- (i) What percentage of the contract will be subcontracted? %
- (ii) The name of the subcontractor
- (iii) The B-BBEE status level of the subcontractor
- (iv) Is the subcontractor an EME? YES/NO

5.1.3 Declaration with regard to Company/Firm

- (i) Name of Company/Firm.....
- (ii) VAT registration number.....
- (iii) Company registration number.....
- (iv) Type of Company / Firm
 - Partnership/Joint Venture/Consortium
 - One person business/sole propriety
 - Close Corporations
 - Company (Pty) Ltd
 - [TICK APPLICABLE BOX]
- (v) Describe Principal Business Activities
.....
.....
.....
.....
- (vi) Company Classification
 - Manufacturer
 - Supplier
 - Professional Service Provider
 - Other Service Providers, e.g Transporter, etc
 - [TICK APPLICABLE BOX]
- (vii) Total number of years the company/firm has been in business.....

"PREVIEW COPY ONLY"

BID DECLARATION

I/we, the undersigned, who warrants that he/she is duly authorised to do so on behalf of the company/firm, certify that points claimed, based on the B-BBEE status level of contribution indicated in paragraph 4 above, qualifies the company/firm for the preference(s) shown and I / we acknowledge that:

- (i) The information furnished is true and correct.
- (ii) In the event of a contract being awarded as a result of points claimed as shown in paragraph 6 above, the contractor may be required to furnish documentary proof to the satisfaction of Transnet that the claims are correct.
- (iii) If the B-BBEE status level of contribution has been claimed or obtained on a fraudulent basis or any of the conditions of contract have not been fulfilled, Transnet may, in addition to any other remedy it may have:
 - (a) disqualify the person from the bidding process;
 - (b) recover costs, losses or damages it has incurred or suffered as a result of that person's conduct;
 - (c) cancel the contract and claim any damages which it has suffered as a result of having to make less favourable arrangements due to such cancellation;
 - (d) restrict the Bidder or contractor, its shareholders and directors, and/or associated entities, or only the shareholders and directors who acted in a fraudulent manner, from obtaining business from Transnet for a period not exceeding 10 years, after the *audi alteram partem* [hear the other side] rule has been applied; and/or
 - (e) forward the matter for criminal prosecution.

WITNESSES:

1.

2.

SIGNATURE OF BIDDER

DATE:

COMPANY NAME:

ADDRESS:.....

.....

.....

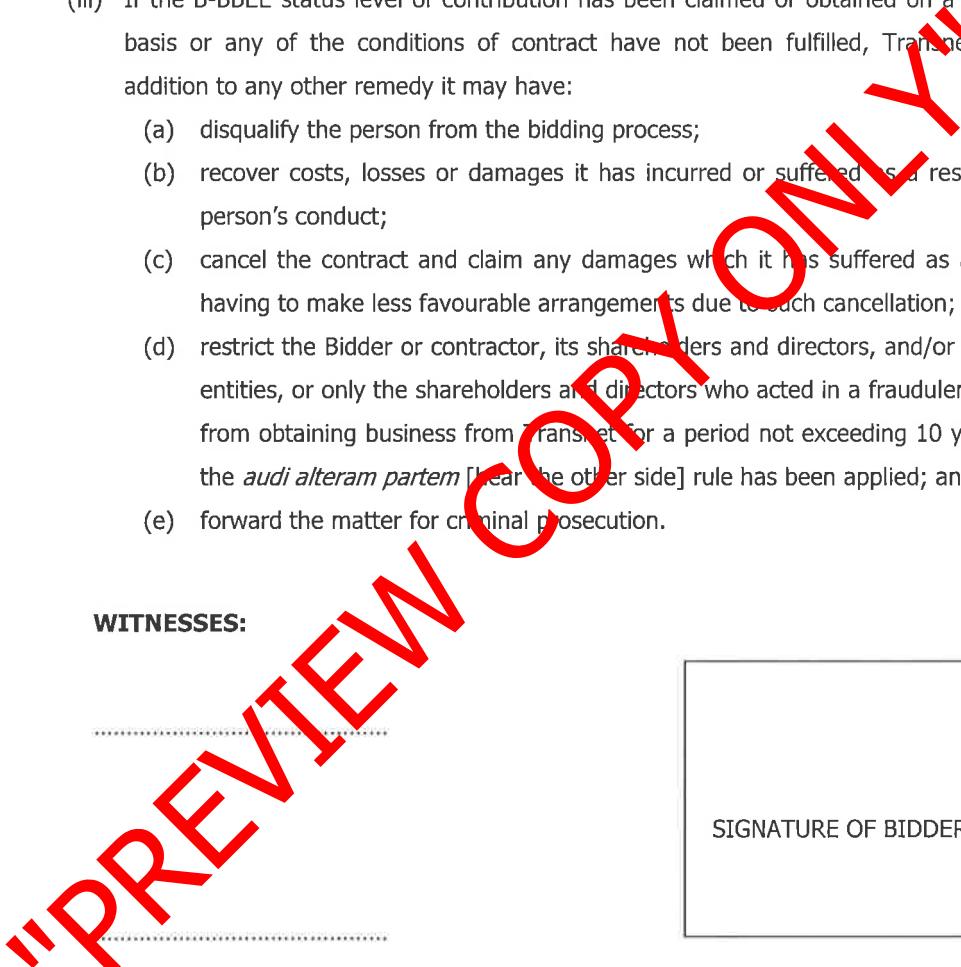

SECTION 6
NON-DISCLOSURE AGREEMENT (NDA)

Entered into by and between

TRANSNET SOC LTD

Registration Number 1990/000900/30

and

Registration Number _____

RFQ Number ERACKT 2290 - 16301

"PREVIEW COPY ONLY"

Respondent's Signature

Date & Company Stamp

THIS AGREEMENT is made between**Transnet SOC Ltd [Transnet]** [Registration No. 1990/000900/30]whose registered office is at 49th Floor, Carlton Centre, 150 Commissioner Street, Johannesburg 2001,**and**_____ [the Company] [Registration No. _____] whose
registered office is at _____**WHEREAS**

Transnet and the Company wish to exchange Information [as defined below] and it is envisaged that each party may from time to time receive Information relating to the other in respect thereof. In consideration of each party making available to the other such Information, the parties jointly agree that any dealings between them shall be subject to the terms and conditions of this Agreement which themselves will be subject to the parameters of the Bid Document.

IT IS HEREBY AGREED**1. INTERPRETATION**

In this Agreement:

- 1.1 **Agents** mean directors, officers, employees, agents, professional advisers, contractors or sub-contractors, or any Group member;
- 1.2 **Bid or Bid Document** means Transnet's Request for Information [RFI] Request for Quotation [RFQ] or Request for Quotation [RFQ], as the case may be;
- 1.3 **Confidential Information** means any information or other data relating to one party [the Disclosing Party] and/or the business carried on or proposed or intended to be carried on by that party and which is made available for the purposes of the Bid to the other party [the Receiving Party] or its Agents by the Disclosing Party or its Agents or recorded in agreed minutes following oral disclosure and any other information otherwise made available by the Disclosing Party or its Agents to the Receiving Party or its Agents, whether before, on or after the date of this Agreement, and whether in writing or otherwise, including any information, analysis or specifications derived from, containing or reflecting such information but excluding information which:
- is publicly available at the time of its disclosure or becomes publicly available [other than as a result of disclosure by the Receiving Party or any of its Agents contrary to the terms of this Agreement]; or
 - was lawfully in the possession of the Receiving Party or its Agents [as can be demonstrated by its written records or other reasonable evidence] free of any restriction as to its use or disclosure prior to its being so disclosed; or
 - following such disclosure, becomes available to the Receiving Party or its Agents [as can be demonstrated by its written records or other reasonable evidence] from a source other

than the Disclosing Party or its Agents, which source is not bound by any duty of confidentiality owed, directly or indirectly, to the Disclosing Party in relation to such information;

- 1.4 **Group** means any subsidiary, any holding company and any subsidiary of any holding company of either party; and
- 1.5 **Information** means all information in whatever form including, without limitation, any information relating to systems, operations, plans, intentions, market opportunities, know-how, trade secrets and business affairs whether in writing, conveyed orally or by machine-readable medium.

2. CONFIDENTIAL INFORMATION

- 2.1 All Confidential Information given by one party to this Agreement [the Disclosing Party] to the other party [the Receiving Party] will be treated by the Receiving Party as secret and confidential and will not, without the Disclosing Party's written consent, directly or indirectly communicate or disclose [whether in writing or orally or in any other manner] Confidential Information to any other person other than in accordance with the terms of this Agreement.
- 2.2 The Receiving Party will only use the Confidential Information for the sole purpose of technical and commercial discussions between the parties in relation to the Bid or for the subsequent performance of any contract between the parties in relation to the Bid.
- 2.3 Notwithstanding clause 2.1 above, the Receiving Party may disclose Confidential Information:
- a) to those of its Agents who strictly need to know the Confidential Information for the sole purpose set out in clause 2.2 above, provided that the Receiving Party shall ensure that such Agents are made aware prior to the disclosure of any part of the Confidential Information that the same is confidential and that they owe a duty of confidence to the Disclosing Party. The Receiving Party shall at all times remain liable for any actions of such Agents that would constitute a breach of this Agreement; or
 - b) to the extent required by law or the rules of any applicable regulatory authority, subject to clause 2.4 below.
- 2.4 In the event that the Receiving Party is required to disclose any Confidential Information in accordance with clause 2.3 b) above, it shall promptly notify the Disclosing Party and cooperate with the Disclosing Party regarding the form, nature, content and purpose of such disclosure or any action which the Disclosing Party may reasonably take to challenge the validity of such requirement.
- 2.5 In the event that any Confidential Information shall be copied, disclosed or used otherwise than as permitted under this Agreement then, upon becoming aware of the same, without prejudice to any rights or remedies of the Disclosing Party, the Receiving Party shall as soon as practicable notify the Disclosing Party of such event and if requested take such steps [including the institution of legal proceedings] as shall be necessary to remedy [if capable of remedy] the default and/or to prevent further unauthorised copying, disclosure or use.

- 2.6 All Confidential Information shall remain the property of the Disclosing Party and its disclosure shall not confer on the Receiving Party any rights, including intellectual property rights over the Confidential Information whatsoever, beyond those contained in this Agreement.

3. RECORDS AND RETURN OF INFORMATION

- 3.1 The Receiving Party agrees to ensure proper and secure storage of all Information and any copies thereof.
- 3.2 The Receiving Party shall keep a written record, to be supplied to the Disclosing Party upon request, of the Confidential Information provided and any copies made thereof and, so far as is reasonably practicable, of the location of such Confidential Information and any copies thereof.
- 3.3 The Company shall, within 7 [seven] days of receipt of a written demand from Transnet:
- a) return all written Confidential Information [including all copies]; and
 - i. expunge or destroy any Confidential Information from any computer, word processor or other device whatsoever into which it was copied, read or programmed by the Company or on its behalf.
- 3.4 The Company shall on request supply a certificate signed by a director as to its full compliance with the requirements of clause 3.3 b) above.

4. ANNOUNCEMENTS

- 4.1 Neither party will make or permit to be made any announcement or disclosure of its prospective interest in the Bid without the prior written consent of the other party.
- 4.2 Neither party shall make use of the other party's name or any information acquired through its dealings with the other party for publicity or marketing purposes without the prior written consent of the other party.

5. DURATION

The obligations of each party and its Agents under this Agreement shall survive the termination of any discussions or negotiations between the parties regarding the Bid and continue thereafter for a period of 5 [five] years.

6. PRINCIPAL

Each party confirms that it is acting as principal and not as nominee, agent or broker for any other person and that it will be responsible for any costs incurred by it or its advisers in considering or pursuing the Bid and in complying with the terms of this Agreement.

7. ADEQUACY OF DAMAGES

Nothing contained in this Agreement shall be construed as prohibiting the Disclosing Party from pursuing any other remedies available to it, either at law or in equity, for any such threatened or actual breach of this Agreement, including specific performance, recovery of damages or otherwise.

8. PRIVACY AND DATA PROTECTION

- 8.1 The Receiving Party undertakes to comply with South Africa's general privacy protection in terms Section 14 of the Bill of Rights in connection with this Bid and shall procure that its personnel shall

observe the provisions of such Act [as applicable] or any amendments and re-enactments thereof and any regulations made pursuant thereto.

- 8.2 The Receiving Party warrants that it and its Agents have the appropriate technical and organisational measures in place against unauthorised or unlawful processing of data relating to the Bid and against accidental loss or destruction of, or damage to such data held or processed by them.

9. GENERAL

- 9.1 Neither party may assign the benefit of this Agreement, or any interest hereunder, except with the prior written consent of the other, save that Transnet may assign this Agreement at any time to any member of the Transnet Group.
- 9.2 No failure or delay in exercising any right, power or privilege under this Agreement will operate as a waiver of it, nor will any single or partial exercise of it preclude any further exercise or the exercise of any right, power or privilege under this Agreement or otherwise.
- 9.3 The provisions of this Agreement shall be severable in the event that any of its provisions are held by a court of competent jurisdiction or other applicable authority to be invalid, void or otherwise unenforceable, and the remaining provisions shall remain enforceable to the fullest extent permitted by law.
- 9.4 This Agreement may only be modified by a written agreement duly signed by persons authorised on behalf of each party.
- 9.5 Nothing in this Agreement shall constitute the creation of a partnership, joint venture or agency between the parties.
- 9.6 This Agreement will be governed by and construed in accordance with South African law and the parties irrevocably submit to the exclusive jurisdiction of the South African courts.

RAIL NETWORK TELECOMS

SCHEDULE OF REQUIREMENTS FOR THE SUPPLY HANDHELD CONVENTIONAL RADIO EQUIPMENT FOR TFR PYRAMID SOUTH

APPENDIX A: SCHEDULE OF COMPLIANCE FOR THE ABOVE:

- Tenders are invited in respect of the following Schedule of Requirements.
- Tenderers must indicate compliance with each item and indicate make and model being offered.
- Alternate offers must be **indicated on separate documents**.

ITEM	DESCRIPTION	COMPLY YES/ NO	MAKE & MODEL	COMMENT
1	HANDHELD REQUIREMENTS			
1.1	UHF, (400 – 470 MHz band) IP54, Handheld conventional radio, with a minimum of 16 conventional 12.5 kHz channels. (Can specify alternative number of channels). Excluding – Antenna, Battery and Charger Must comply with attached Specifications BBD8635 version 8 dated 21 May 2014 and BBG 1946 version 1 dated 22 May 2014.			
1.2	Quarter wave flexible whip antenna for item 1.1, to cover the 455 to 467 MHz band.			
1.3	High capacity Battery to fit item 1.1 capable of sustaining a 20 - 20 - 60 duty cycle for an 8 hour shift. (Tx, Rx, Standby).			
1.4	Single bay rapid rate Charger for item 1.1 Provision must be made for a standard 3 pin 15 amp mains plug.			
1.5	Leather carry bag for item 1 with shoulder strap.			
1.6	Programming software, Leads, Adaptors and technical manuals on CD.			

SCHEDULE OF REQUIREMENTS
FOR THE SUPPLY OF RADIO EQUIPMENT

APPENDIX B & C: BILL OF QUANTITIES AND COST SCHEDULE

Indicate the cost per unit for the quantities indicated in the respective columns.

ITEM	DESCRIPTION	QTY	UNIT PRICE	TOTAL
2	HANDHELD REQUIREMENTS			
2.1	UHF, (400 – 470 MHz band) IP54, Handheld conventional radio, with a minimum of 16 conventional 12.5 kHz channels. (Can specify alternative number of channels). Excluding – Antenna, Battery and Charger Must comply with attached Specifications BBD8635 version 8 dated 21 May 2014 and BBG 1946 version 1 dated 22 May 2014.	65		
2.2	Quarter wave flexible whip antenna for item 1.1, to cover the 455 to 467 MHz band.	65		
2.3	High capacity Battery to fit item 1.1, capable of sustaining a 20 - 20 - 60 duty cycle for an 8 hour shift. (Tx, Rx, Standby).	65		
2.4	Single bay rapid rate Charger for item 1.1 Provision must be made for a standard 3 pin 15 amp mains plug.	65		
2.5	Leather carry bag for item 1 with shoulder strap.	65		
2.6	Programming software, Leads & Adaptors, technical manuals.	5		

"PREVIEW COPY ONLY"

SCHEDULE OF REQUIREMENTS
FOR THE SUPPLY OF RADIO EQUIPMENT

APPENDIX D: DELIVERY PERIOD

Indicate the delivery period, in weeks, for the quantities as indicated in the bill of quantities above:

ITEM	DESCRIPTION	QTY	DELIVERY DATE	COMMENT
3	HANDHELD REQUIREMENTS			
3.1	UHF, (400 – 470 MHz band) IP54, Handheld conventional radio, with a minimum of 16 conventional 12.5 kHz channels. (Can specify alternative number of channels). Excluding – Antenna, Battery and Charger Must comply with attached Specifications BBD8635 version 8 dated 21 May 2014 and BBG 1946 version 1 dated 22 May 2014.	65		
3.2	Quarter wave flexible whip antenna for item 1.1, to cover the 455 to 467 MHz band.	65		
3.3	High capacity Battery to fit item 1.1, capable of sustaining a 20 - 20 - 60 duty cycle for an 8 hour shift. (Tx, Rx, Standby).	120		
3.4	Single bay rapid rate Charger for item 1.1. Provision must be made for a standard 3 pin 15 amp mains plug.	65		
3.5	Leather carry bag for item 1 with shoulder strap.	65		
3.6	Programming software, Leads & Adaptors, technical manuals.	5		

APPENDIX E: DELIVERY SCHEDULE

The supplied equipment must be delivered to the following location.

TRANSNET FREIGHT RAIL
Radio Workshop
Corner of Hospital and Church Street
(behind GANE)
Polokwane

Box to be labelled: 50 Conventional Radios for Pyramid South, Scotty Scott, Room 562 NZASM Building, Minnaar Street, Pretoria, Tel 012 315 2086/4028

CONTACT: Prior to delivery

Chris Schutte
015-299-6321 Office
083 297 9325 Cell

TECHNICAL QUERIES

Prem Naicker
012 315 3410
083 460 5897

RAIL NETWORK TELECOMS

SCHEDULE OF REQUIREMENTS FOR THE SUPPLY HANDHELD TRUNKED AND CONVENTIONAL RADIO EQUIPMENT FOR TFR Pyramid South

APPENDIX A: SCHEDULE OF COMPLIANCE FOR THE ABOVE:

- Tenders are invited in respect of the following Schedule of Requirements.
- Tenderers must indicate compliance with each item and indicate make and model being offered.
- Alternate offers must be indicated on separate documents.

ITEM	DESCRIPTION	COMPLY YES/ NO	MAKE & MODEL	COMMENT
1	HANDHELD REQUIREMENTS			
1.1	UHF, (400 – 470 MHz band) IP54, Handheld Trunked and Conventional radio, with a minimum of 16 conventional 12.5 kHz channels. (Can specify alternative number of channels). Excluding antenna and battery Must comply with attached Specifications BBD 8635 version 8 dated 21 May 2014 and BBF 2515 version 3.00, dated 6 June 2014.			
1.2	Quarter wave flexible whip antenna for item 1.1, to cover the 455 to 467 MHz band.			
1.3	High capacity Battery to fit item 1.1, capable of sustaining a 20 - 20 - 60 duty cycle for an 8 hour shift. (Tx, Rx, Standby).			
1.4	Single bay rapid rate Charger for item 1.1 Provision must be made for a standard 3 pin 15 amp mains plug.			
1.5	Leather carry bag for item 1 with shoulder strap.			
1.6	Programming software, Leads, Adaptors and technical manuals on CD.			

SCHEDULE OF REQUIREMENTS
FOR THE SUPPLY OF RADIO EQUIPMENT

APPENDIX B & C: BILL OF QUANTITIES AND COST SCHEDULE

Indicate the cost per unit for the quantities indicated in the respective columns

ITEM	DESCRIPTION	QTY	UNIT PRICE	TOTAL
2	HANDHELD REQUIREMENTS			
2.1	UHF, (400 – 470 MHz band) IP54, Handheld Trunked and Conventional radio, with a minimum of 16 conventional 12.5 kHz channels. (Can specify alternative number of channels). Excluding antenna and battery Must comply with attached Specifications BBD 8635 version 8 dated 21 May 2014 and BBF 2615 version 3.00, dated 6 June 2014.	45		
2.2	Quarter wave flexible whip antenna for item 1.1, to cover the 455 to 467 MHz band.	45		
2.3	High capacity Battery to fit item 1.1, capable of sustaining a 20 - 20 - 60 duty cycle for an 8 hour shift. (Tx, Rx, Standby).	45		
2.4	Single bay rapid rate Charger for item 1.1 Provision must be made for a standard 3 pin 15 amp mains plug.	45		
2.5	Leather carry bag for item 1 with shoulder strap.	45		
2.6	Programming software, Loads, Adaptors, technical manuals.	5		

"PREVIEW COPY ONLY"

SCHEDULE OF REQUIREMENTS
FOR THE SUPPLY OF RADIO EQUIPMENT

APPENDIX D: DELIVERY PERIOD

Indicate the delivery period, in weeks, for the quantities as indicated in the bill of quantities above:

ITEM	DESCRIPTION	QTY	DELIVERY DATE	COMMENT
3	HANDHELD REQUIREMENTS			
3.1	UHF, (400 – 470 MHz band) IP54, Handheld Trunked and Conventional radio, with a minimum of 16 conventional 12.5 kHz channels. (Can specify alternative number of channels). Excluding antenna and battery Must comply with attached Specifications BBD 8635 version 8 dated 21 May 2014 and BBF 2615 version 3.00, dated 6 June 2014.	45		
3.2	Quarter wave flexible whip antenna for item 1.1, to cover the 455 to 467 MHz band.	45		
3.3	High capacity Battery to fit item 1.1, capable of sustaining a 20 - 20 - 60 duty cycle for an 8 hour shift. (Tx, Rx, Standby).	40		
3.4	Single bay rapid rate Charger for item 1.1 Provision must be made for a standard 3 pin 15 amp mains plug.	45		
3.5	Leather carry bag for item 1 with shoulder strap.	45		
3.6	Programming software, Leads, Adaptors, technical manuals.	5		

APPENDIX E: DELIVERY SCHEDULE

The supplied equipment must be delivered to the following location.

TRANSNET FREIGHT RAIL
Pretoria Radio Workshop
The Millhouse
598 Thabo Sehume Street
Pretoria

CONTACT: Prior to delivery

Richard Daneel
012 315 4170 Office
083 267 5757 Cell

Box to be labelled: Trunk Radios – Pyramid South (Scotty Scott) room 562 NZASM Building, Minnaar street, Pretoria

TECHNICAL QUERIES:

Prem Naicker
012-3153410
083 460 5897



TRANSNET
freight rail

**RAIL NETWORK
TELECOMMUNICATION**

**SPECIFICATION
BBF 2516 VERSION 3.00**

**SPECIFICATION FOR UHF HANDHELD
TRUNKED AND CONVENTIONAL RADIO**

Author: Manager Radio
Rail Network
Telecommunication Radio

G. A Daly

Reviewed: Senior Engineer
Rail Network
Telecommunication Radio

M. Mmbengwa

Reviewed: Manager Regulatory
Rail Network
Telecommunication Radio

Y. Kedama

Authorised: Chief Engineer
Rail Network
Telecommunication

A. Matseke

Date 24 June 2014

Circulation Restricted To:
Transnet Freight Rail
Transnet and Relevant Third Parties
Unrestricted

© This document as a whole is protected by copyright. The information herein is the sole property of Transnet Ltd. It may not be used, disclosed or reproduced in part or in whole in any manner whatsoever, except with the written permission of and in a manner permitted by the proprietors.

"PREVIEW COPY ONLY"

Contents

I. Document Authorisation I

II. Distribution I

III. Document Change History I

IV. Changes since Last Revision I

V. List of Abbreviations and Acronyms II

VI. Relevant Documentation Applicable III

1. INTRODUCTION 1

2. SCOPE 1

3. COMPLIANCE 1

4. TENDER REQUIREMENTS 2

5. TECHNICAL REQUIREMENT 3

6. TRAINING 5

"PREVIEW COPY ONLY"

I. Document Authorisation

FUNCTION	NAME	TITLE & DIVISION	DATE
Reviewed By:	Freddie Visser	Frequency Management Rail Network	<i>Freddie Visser</i> 26 June 2014
Reviewed By:	Chris Muller	Quality Assurance Rail Network	<i>Chris Muller</i> 26 June 2014

II. Distribution

Once updated, a copy of the latest revision will be published on the document management system, "Project Wise".

III. Document Change History

ISSUE NO.	DATE ISSUED	ISSUED BY	HISTORY DESCRIPTION
1.00	October 2011	Robert Yates	New Document
2.00	November 2012	Graeme Daly	New Document
2.01	December 2012	Graeme Daly	Revised 5.17 & 5.18
2.02	May 2013	Graeme Daly	Signatory & Revision 4.1
3.00	June 2014	Graeme Daly	Revised Document

IV. Changes since Last Revision

CLAUSES	DESCRIPTION
5.17 & 5.18	Channel Availability
5.2, 5.3	Revised clauses
	Revised Document

V. List of Abbreviations and Acronyms

ABBREVIATIONS AND ACRONYMS	DESCRIPTION
AC	Alternating Current
Ah	Ampere hour
EC Amendment Act	Electronic Communications Amendment Act No.1 2014
BS	British Department of Trade and Industry Specification
dBm	Decibel relative to 1 milli watt
LED	Light Emitting Diode
m	Metre
mm	Millimetre
MPT	Minister of Post and Telecommunication
PTT	Press – To - Talk
RBU	Radio Base Unit
RCU	Remote Control Unit
RF	Radio Frequency
RTO	Radio Train Order
Rx	Receve
TFR	Transnet Freight Rail
THD	Total Harmonic Distortion
Tx	Transmit
UHF	Ultra High Frequency
V	Volt
W	Watt
Char	Character
CTC	Central Train Control
CTCSS	Continuous Tone Code Squelch System
dB(A)	Sound pressure A-weighted
DC	Direct Current
GPS	Global Positioning System
ICASA	Independent Communication Authority of South Africa
ID	Identification
IP	International Protection
mW	Milli watt
RF	Radio Frequency
TCO	Train Controlling Officer
UHF	Ultra High Frequency
VCO	Voltage Control Oscillator
VSWR	Voltage Standing Wave Ratio
NTC	National Test Centre
RFQ	Request for quotation

VI. Relevant Documentation Applicable

Where there is a conflict between the SPECIFICATION and SCHEDULE OF REQUIREMENT DOCUMENT, the SCHEDULE OF REQUIREMENT DOCUMENT takes precedence.

The equipment must comply with the latest issue of the following applicable specifications:

DOCUMENT NO.	DESCRIPTION	LOCATION
ISO 9000	Quality Management Systems.	External
ETSI EN 300 086	European Telecommunication Standards for Radios.	External
GG 3736	Electronic Communications Amendment Act No.1 2014	External
BS 3939	British Department of Trade and Industry Specification:	External
MPT 1317	Code of Practice for Transmission of Digital Information over Land Mobile Radio Systems.	External
MPT 1327	A signalling Standard for Trunked Private Mobile Radio Systems	External
MPT 1343	System Interface Specification for Radio Units to be used with Commercial Trunked Networks	External
BBD 8635 Version 8 22 May 2014	Technical specifications and methods of measurement for angle modulated equipment	Internal
IP 54	Dust protected. Protected against splashing of water.	External
IP 55	Dust protected. Protected against water jets.	External
IP 57	Dust protected. Protected against the effect of immersion between 15 cm and 1 m.	External
IP 67	Totally protected against dust. Protected against the effect of immersion between 15 cm and 1 m.	External

"PREVIEW COPY ONLY"

1. INTRODUCTION

Transnet utilise UHF Handheld - Trunked and Conventional radio equipment, to control train shunting movements, communicate with train control officers, flagmen, shipping and harbours operations, etc.

2. SCOPE

- 2.1. This specification is for the supply of the above radio equipment and accessories as per attached Schedule of Requirements. (Appendix A).
- 2.2. This specification will provide Bill of Quantities and Cost Schedule, as per attached. (Appendix B & C)
- 2.3. It is envisaged that equipment for this enquiry will be ordered and supplied to Transnet Freight Rail's nominated address. (Appendix D & E).

3. COMPLIANCE

Item	Description	Comply	Remarks
3.1.	Tenderers shall submit a clause-by-clause statement of compliance for this Technical Specification BBF 2516 version 3.00, dated 6 June 2014, in the columns provided. *Failure to comply will exclude Tenderers from consideration.		
3.2.	Alternative offers, will be considered at Transnet Freight Rail's discretion, provided that such offers provide equivalent functionality to what has been specified in this document. Separate compliance documents must be completed for each alternative offer. (Appendix A - B & C - D & E) *Failure to comply will exclude Tenderers from consideration.		
3.3.	The successful bidder is obligated as per the Act to ensure Transnet is in possession of a valid frequency spectrum licence, for the Radio to be supplied. A reference must be obtained from Transnet Frequency Spectrum Manager Mr Freddie Visser, at Freddie.Visser@Transnet.net or at 011 583 0125 prior to the delivery. *Failing to adhere to the above will result in the cancellation of the transaction and the matter will be reported to ICASA.		
3.4.	Radio's that comply with Technical Specifications BBD 8635 version 8, dated 21 May 2014 and this specification BBF 2516 version 3.00, dated 6 June 2014, but have not yet been submitted to Transnet for evaluation, must be submitted to the Transnet National Test Centre (NTC) to 2 Foley St. Factoria, Krugersdorp, Gauteng, attention Mr Chris Muller 011 774 8229 prior to, or, within 5 (Five) working days after the tender has closed. Approval letter from Transnet NTC must be included in the Tender/RFQ for each product offered. *Failure to comply will exclude Tenderers from consideration.		

Item	Description	Comply Y/N	Remarks
3.5.	All programming software, accessories, test interface box / cables, service manuals, ICASA certificate, etc. must be submitted with the radio when being delivered to the NTC for evaluation. Refer to document BBD 8635, for requirements. *Failure to comply will exclude Tenderers from consideration		
3.6.	This Specification BBF 2516 must be read in conjunction with Technical Specification and Method of Measurement for Angle Modulated Radio Equipment BBD 8635 Version 8, dated 21 May 2014. *Failure to comply will exclude Tenderers from consideration		
3.7.	The equipment offered must be ICASA equipment type approved and a certificate per model offered must be submitted. *Failure to comply will exclude Tenderers from consideration.		
3.8.	Tenderers must provide a copy of their current ICASA Radio Dealers certificate. *Failure to comply will exclude Tenderers from consideration.		
3.9.	Radio's will be required to be batch tested by Transnet NTC prior to delivery or shipment. *Failure to comply will result in the termination of the order when radio equipment is delivered.		

4. TENDER REQUIREMENTS

Item	Description	Comply Y/N	Remarks
4.1.	Tenderers shall submit a clause-by-clause statement of compliance for equipment / items offered on the attached Schedule of Requirements (Appendix A) in the columns provided. *Failure to comply will exclude Tenderers from consideration.		
4.2.	Tenderers shall complete the attached Cost Schedule (Appendix B & C) for equipment. *Tenderers will be excluded from supplying any items not priced.		
4.3.	Tenderers shall complete the attached Delivery Schedule (Appendix D & E) for equipment. *Tenderers will be excluded from supplying if delivery dates are not included, as this will be a deciding factor.		

5. TECHNICAL REQUIREMENT

Item	Description	Comply Y/N	Remarks
5.1.	Technical specifications for Items offered must be submitted. *Failure to comply will exclude Tenderers from consideration.		
5.2.	The Receiver loudspeaker must comply with a sound pressure level equal to or better than ≤ 84 dB (A) at 300 mm. Refer to document BBD 8635 version 8, dated 21 May 2014 for test method.		
5.3.	The Transmitter deviation must be between 300 - 500 Hz from sound pressure level of 80 dB (A) at the microphone. Refer to document BBD 8635 version 8, dated 21 May 2014 for test method.		
5.4.	Radios must be capable of handling a frequency switching bandwidth of 15 MHz on both transmit and receive between channels with no degradation.		
5.5.	Radios must be programmable in the 400 - 470 MHz band without signal degradation nor component or board changes - to be specified.		
5.6.	Radio's must operate with 12,5 kHz channel spacing.		
5.7.	The handheld radio Tx output power must be software selectable between 1 and 4 watts, or to be specified.		
5.8.	In conventional mode, the handheld radio must have a minimum of 10 channels. (Can specify alternative number of channels)		
5.9.	The display on the radio must have a minimum of twelve alpha numeric characters.		
5.10.	It must be possible to assign an alpha - numeric label to each conventional channel.		
5.11.	Radios must be IP54 compliant or better.		
5.12.	Battery capacity must be capable of sustaining an 8 hour shift, with a duty cycle of 20, 20, 60. (Transmit, Receive, Standby)		
5.13.	Battery capacity to be declared in mAh.		

Item	Description	Comply Y/N	Remarks
5.14.	Battery chemical composition to be provided.		
5.15.	Battery Model number must be provided.		
5.16.	Radio key pad must have a lock - out facility after a channel has been selected.		
5.17.	Rotary channel selector switch must be able to be disabled with software.		
5.18.	Birth date of radio. (when was it released into the market)		
5.19.	Date expected to be withdrawn, superseded or replaced from the market. (Manufacture official letter to be provided)		
5.20.	Warranty period, exceptions, terms and conditions to be indicated.		
5.21.	Warranty period of radio to be indicated.		
5.22.	Warranty turn - around time for repairs to be specified in working days.		
5.23.	Supplier must prove that warranty repairs and technical support can be carried out on its own premises.		
5.24.	Spares and technical support must be readily available locally for a period of at least seven years from date of purchase.		
5.25.	Equipment returned from repairs must be fully aligned to meet the specification of compliance. Certification must be issued and random batch testing will be performed.		
5.26.	Service manuals must be in English and available on CD-ROM.		
5.27.	Programming software must be on CD-ROM.		
5.28.	Programming software must be Microsoft Windows 7 compatible.		
5.29.	The selection between Trunked and Conventional modes must be easily selectable.		

"PREVIEW COPY ONLY"

Item	Description	Comply Y/N	Remarks
5.30.	Trunked handheld radio must operate in accordance with MPT 1327 and MPT 1343 standards.		
5.31.	Trunked radio handheld must have a User Selectable inclusive and exclusive Group call facility catering for 100 Groups.		

6. TRAINING

Item	Description	Comply Y/N	Remarks
6.1.	Tenderers must be in a position to provide training on all products offered, country wide.		
6.2.	Training required on products will be indicated in the schedule of requirements.		

END OF DOCUMENT

"PREVIEW COPY ONLY"







TRANSNET
freight rail

**RAIL NETWORK
TELECOMMUNICATION**

**SPECIFICATION
BBG 1946 VERSION 2.00**

**SPECIFICATION FOR UHF HANDHELD CONVENTIONAL
RADIO**

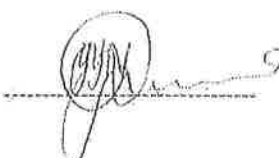
"PREVIEW COPY ONLY"

Author:	Manager Radio Rail Network Telecommunication Radio	G. A Daly	
Reviewed:	Senior Engineer Rail Network Telecommunication Radio	M. Mmbengwa	
Reviewed:	Manager Regulatory Rail Network Telecommunication Radio	Y. Kedama	
Authorised:	Chief Engineer Rail Network Telecommunication	A. Matseke	
		Date	24 June 2014

Circulation Restricted to:

- Transnet Freight Rail
- Transnet and Relevant Third Parties
- Unrestricted

© This document as a whole is protected by copyright. The information herein is the sole property of Transnet Ltd. It may not be used, disclosed or reproduced in part or in whole in any manner whatsoever, except with the written permission of and in a manner permitted by the proprietors.

Contents

I. Document Authorisation.....I

II. DistributionI

III. Document Change History.....I

IV. Changes since Last RevisionI

V. List of Abbreviations and Acronyms.....II

VI. Relevant Documentation ApplicableIII

1. INTRODUCTION.....1

2. SCOPE.....1

3. COMPLIANCE1

4. TENDER REQUIRMENTS.....2

5. TECHNICAL REQUIREMENTS3

6. TRAINING5

"PREVIEW COPY ONLY"

I. Document Authorisation

FUNCTION	NAME	TITLE & DIVISION	DATE
Reviewed By:	Freddie Visser	Frequency Spectrum Management Rail Network	24 June 2014
Reviewed By:	Chris Muller	Quality Assurance Rail Network	26 June 2014

II. Distribution

Once updated, a copy of the latest revision will be published on the document management system, "Project Wise".

III. Document Change History

ISSUE NO.	DATE ISSUED	ISSUED BY	HISTORY DESCRIPTION
1.00	21 May 2014	Graeme Daly	New Document
2.00	6 June 2014	Graeme Daly	Clause 3.5, 3.9 & 5.9

IV. Changes since Last Revision

CLAUSE	DESCRIPTION
3.5	Added clause
3.9	Added clause
5.9	Reduced number of alpha numeric characters on the display

V. List of Abbreviations and Acronyms

ABBREVIATIONS AND ACRONYMS	DESCRIPTION
AC	Alternating Current
Ah	Ampere hour
EC Amendment Act	Electronic Communications Amendment Act No.1 2014
dBm	Decibel relative to 1 milli watt
ICASA	Independent Communication Authority of South Africa
LED	Light Emitting Diode
m	Metre
cm	Centimetres
mm	Millimetre
PTT	Press - to - Talk
RBU	Radio Base Unit
RCU	Remote Control Unit
RF	Radio Frequency
RTO	Radio Train Order
Rx	Receive
TCO	Train Control Officer
TFR	Transnet Freight Rail
THD	Total Harmonic Distortion
Tx	Transmit
UHF	Ultra High Frequency
V	Volt
W	Watt
Char	Character
CTC	Central Train Control
CTCSS	Continuous tone code squelch system
dB(A)	Sound pressure A-weighted
DC	Direct Current
GPS	Global positioning system
ICASA	Independent Communication Authority of South Africa
ID	Identification
mW	Milliwatt
RF	Radio Frequency
TCO	Train controlling officer
UHF	Ultra High Frequency
VCO	Voltage Control Oscillator
VSWR	Voltage Standing Wave Ratio
NTC	National Test Centre (Radio)
RFQ	Request for quotation

VI. Relevant Documentation Applicable

Where there is a conflict between the SPECIFICATION and SCHEDULE OF REQUIREMENT DOCUMENT, the SCHEDULE OF REQUIREMENT DOCUMENT takes precedence.

The equipment must comply with the latest issue of the following applicable specifications:

DOCUMENT NO.	DESCRIPTION	LOCATION
ISO 9000	Quality Management Systems.	External
ETSI EN 300 086	European Telecommunication Standards for Radios.	External
GG 3736	Electronic Communications Amendment Act No.1 2014	External
BS 3939	British Department of Trade and Industry Specification:	External
BBD 8635 Version 8 22 May 2014	Technical specifications and method of measurement for angle modulated equipment.	Internal
IP 54	Dust protected. Protected against splashing of water.	External
IP 55	Dust protected. Protected against water jets.	External
IP 57	Dust protected. Protected against the effect of immersion between 15 cm and 1 m.	External
IP 67	Totally protected against dust. Protected against the effect of immersion between 15 cm and 1 m.	External

1. INTRODUCTION

Transnet utilise UHF handheld conventional radio equipment to control trains, shunting movements, communicate with train control officers, flagmen, shipping and harbours operations, etc.

2. SCOPE

- 2.1. This specification is for the supply of the above radio equipment and accessories as per attached Schedule of Requirements. **(Appendix A)**.
- 2.2. Bill of Quantities and Cost Schedule as per attached. **(Appendix B & C)**.
- 2.3. It is envisaged that equipment for this enquiry will be ordered and supplied to Transnet Freight Rail's nominated address. **(Appendix D & E)**.

3. COMPLIANCE

Item	Description	Comments	Remarks
3.1.	Tenderers must comply with the clause-by-clause statement of the tender requirements provided below. *Failure to comply will exclude Tenderers from consideration.		
3.2.	Alternative offers, will be considered at Transnet Freight Rail's discretion, provided that such offers provide equivalent functionality to what has been specified in this document. Separate compliance documents must be completed for each alternative offer. (Appendix A - B & C - D & E) *Failure to comply will exclude Tenderers from consideration.		
3.3.	The successful bidder is obligated as per the Act to ensure Transnet is in possession of a valid frequency spectrum licence for the Radio's to be supplied. A reference must be obtained from Transnet Frequency Spectrum Manager Mr Freddie Visser, at Freddie.Visser@Transnet.net or at 011 583 0125 prior to the delivery. *Failure to adhere to the above will result in the cancellation of this transaction and the matter will be reported to ICASA.		
3.4.	Radio's that comply with Technical Specifications BBD 8635 version 8 dated 21 May 2014 and this specification BBG 1946 but has not yet being submitted to Transnet for evaluation, must be submitted to the Transnet National Test Centre (NTC) to 2 Foley St. Fectoria, Krugersdorp, Gauteng, attention Mr Chris Muller 011 774 8229 prior to, or, within 5 (Five) working days after the tender has closed. Approval letter from Transnet NTC must be included in the Tender/RFQ for each product offered. *Failure to comply will exclude Tenderers from consideration.		

Item	Description	Comply Y/N	Remarks
3.5.	All programming software, accessories, test interface box / cables, service manuals, ICASA certificate, etc. must be submitted with the radio when being delivered to the NTC for evaluation. Refer to document BBD 8635, for requirements. *Failure to comply will exclude Tenderers from consideration.		
3.6.	This Specification BBG 1946 must be read in conjunction with Technical Specification and Method of Measurement for Angle Modulated Radio Equipment BBD 8635 version 8, dated 21 May 2014. *Failure to comply will exclude Tenderers from consideration		
3.7.	The equipment offered must be ICASA equipment type approved, certificates per model offered must be submitted. *Failure to comply will exclude Tenderers from consideration.		
3.8.	Tender must provide a copy of their current ICASA radio certificate. *Failure to comply will exclude Tenderers from consideration.		
3.9.	Radio will be required to be batch tested by Transnet NTC prior to deliver or shipment. *Failure to comply will result in the termination of the order when radio equipment is delivered.		

4. TENDER REQUIREMENTS

Item	Description	Comply Y/N	Remarks
4.1.	Tenderers shall submit a clause-by-clause statement of compliance for equipment / Items offered on the attached Schedule of Requirements (Appendix A) in the columns provided. *Failure to comply will exclude Tenderers from consideration.		
4.2.	Tenderers shall complete the attached Cost Schedule (Appendix B & C) for equipment. *Tenderers will be excluded from supplying any items not priced.		
4.3.	Tenderers shall complete the attached Delivery Schedule (Appendix D & E) for equipment. *Tenderers will be excluded from supplying if delivery dates are not included, as this will be a deciding factor.		

5. TECHNICAL REQUIREMENTS

Item	Description	Comply Y/N	Remarks
5.1.	Technical specifications for items offered must be submitted. *Failure to comply will exclude Tenderers from consideration.		
5.2.	The Receiver loudspeaker must comply with a sound pressure level equal to or better than ≤ 84 dB (A) at 300 mm. Refer to document BBD 8635 version, 8 dated 21 May 2014 for test method.		
5.3.	The Transmitter deviation must be between 300 - 500 Hz from sound pressure level of 80 dB (A) at the microphone. Refer to document BBD 8635 version 8, dated 21 May 2014 for test method.		
5.4.	Radios must be capable of handling a frequency switching bandwidth of 15 MHz on both transmit and receive between channels with no degradation.		
5.5.	Radios must be programmable in the 400 - 470 MHz band without signal degradation nor component or board changes - to be specified.		
5.6.	Radio must operate with 12.5 kHz channel spacing.		
5.7.	The handheld radio RF output power must be software selectable between 1 and 4 watts, or to be specified.		
5.8.	Conventional handheld radio must have a minimum of 16 channels. (Can specify alternative number of channels)		
5.9.	The display on the radio must have a minimum of twelve alpha numeric characters.		
5.10.	It must be possible to assign an alpha - numeric label to each conventional channel.		
5.11.	Radios must be IP54 compliant or better.		
5.12.	Battery capacity must be capable of sustaining an 8 hour shift, with a duty cycle of 20, 20, 60. (Transmit, Receive, Standby)		
5.13.	Battery capacity to be declared in mAh.		

Item	Description	Comply Y/N	Remarks
5.14.	Battery chemical composition to be provided.		
5.15.	Battery Model number must be provided.		
5.16.	Radio key pad must have a lock - out facility after a channel has been selected.		
5.17.	Rotary channel selector switch must be able to be disabled with software.		
5.18.	Birth date of radio. (when was it released into the market)		
5.19.	Date expected to be withdrawn, superseded or replaced from the market. (Manufacture official letter to be provided)		
5.20.	Warranty period, exceptions, terms and conditions to be indicated.		
5.21.	Warranty period of radio to be Indicated.		
5.22.	Warranty turn - around time for repairs to be specified in working days.		
5.23.	Supplier must prove that warranty repairs and technical support can be carried out on its own premises.		
5.24.	Spares and technical support must be readily available locally for a period of at least seven years from date of purchase.		
5.25.	Equipment returned from repairs must be fully aligned to meet the specification of compliance. Certification must be issued and random batch testing will be performed.		
5.26.	Service manuals must be in English and available on CD-ROM.		
5.27.	Programming software must be on CD-ROM.		
5.28.	Programming software must be Microsoft Windows 7 compatible.		

6. TRAINING

Item	Description	Comply Y/N	Remarks
6.1.	Tenderers must be in a position to provide training on all products offered, country wide.		
6.2.	Training required on products will be indicated in the schedule of requirements.		

END OF DOCUMENT

"PREVIEW COPY ONLY"



TRANSNET
freight rail

A Division of Transnet Limited

INFRASTRUCTURE TELECOMS

STANDARD

**TECHNICAL SPECIFICATION AND METHODS OF
MEASUREMENT FOR ANGLE MODULATED RADIO
EQUIPMENT**

Author: Senior Engineering Technician
Quality Assurance, National
Test Centre

C J Muller

Approved: Principal Engineer
Transmission Engineering

M L Nuttall
PP
MUHUMBULO
MIMBENGA

Date: 21 May 2014

Circulation Restricted To:

Transnet Freight Rail
Transnet and Relevant Third Parties

© This document as a whole is protected by copyright. The information herein is the sole property of Transnet Ltd. It may not be used, disclosed or reproduced in part or in whole in any manner whatsoever, except with the written permission of and in a manner permitted by the proprietors.

CONTENTS

I.	Distribution.....	3
II.	Document Change History	3
III.	Changes Since Last Revision	3
IV.	List of Abbreviations and Definitions	3
1.	Technical Specification.....	8
1.1	Radio Receiver	8
1.2	Radio Transmitter	9
1.3	Radio Base Station	11
1.4	Filters	12
1.5	Coaxial Cable	12
1.6	Antenna	12
1.7	Transmitting Power.....	13
1.8	Receiver Desensing	13
1.9	Audio Line Branching Unit.....	13
1.10	Power Supply Unit & Battery Charger	14
1.11	Trunking.....	14
1.12	Acoustical Measurements	15
1.13	Co-Channel Interference	15
2.	Methods of Measurement.....	17
2.1.	Applied Standard	17
2.2.	Radio Receiver	18
2.3.	Radio Transmitter	29
2.4.	High Site Equipment	38
2.4.1	Radio Base Station Response Time	38
2.4.2	Talk Through Signal	39
2.4.3	Filters	43
2.4.4	Coaxial Cable.....	46
2.4.5	Antenna	47
2.4.6	Receiver Desensing	48
2.4.7	Audio Line Branching Unit.....	48
2.4.8	Power Supply Unit & Battery Charger	53
2.5.	Trunking Functional Tests	56
2.6.	Acoustical Measurements	57
3.	Relevant Documentation	58

I Distribution

Once updated, a copy of the latest revision will be published in the document management system in use. An e-mail to this effect will be sent to the relevant personnel or heads of department.

II Document Change History

ISSUE NO.	DATE ISSUED	ISSUED BY	HISTORY DESCRIPTION
2.00	January 2004	Quality Assurance, Infrastructure	Revision
3.0	June 2006	QA	Convert to ISO Standard
3.1	June 2007	QA	Revision
4.0	July 2008	QA	Revision
5.0	February 2010	QA	New format & revision
6.0	August 2010	QA	New format & revision
6.1	November 2010	QA	Add measurement
6.2	August 2011	QA	Add information, definitions, supply standards, DC-DC converter
7.0	January 2012	QA	Revision & add trunking functional tests
8.0	May 2014	QA	Quit the difference between General and Shunt portables, revise the Loudspeaker sound pressure level & Transmitter microphone sensitivity.

III Changes Since Last Revision

CLAUSES	DESCRIPTION
IV	Add abbreviations
1.3.3.5	Change specification
1.11	Add trunking
2.4.2.3	Change graph
2.5	Add trunking functional tests
1.12	Quit the difference between General and Shunt portables, revise the Loudspeaker sound pressure level & Transmitter microphone sensitivity.

IV List of Abbreviations and Definitions

ABBREVIATIONS	DESCRIPTION
AC	Alternating Current
AF	Audio Frequency
BS	Base Station
CCITT	Consultative Committee for International Telephone and Telegraph (ITU-T)
CTCSS	Continuous Tone Coded Squelch System
dB	Decibel
dB(A)	Sound pressure A-weighted
dBc	Decibel relative to the carrier power
dBd	Decibel relative to a Dipole antenna
dBm	Decibel relative to 1 mW, impedance 50 Ω (power)
dBm	Decibel relative to 0.775 V _{pd} , impedance 600 Ω (audio frequency)
dB _{MUOP}	Decibel relative to the Maximum Useful Output Power
dB _{SOP}	Decibel relative to the Standard Output Power
DC	Direct Current
EMF	Electromotive Force
ERP	Effective Radiated Power
FFSK	Fast Frequency Shift Keying

FM	Frequency Modulation
GSM	Global System for Mobile communication
Hz	Hertz
ITU-T	International Telecommunication Union – Telecommunication Standardization Sector
kHz	Kilohertz
LBU	Line Branching Unit
LS	Loudspeaker
m	Metre
mA	Milliampere
MHz	Megahertz
mm	Millimetre
ms	Millisecond
mVp-p	Millivolt peak-to-peak
mW	Milliwatt
MUOP	Maximum Useful Output Power
pd	Potential Difference
PM	Phase Modulation
PSTN	Private Switching Telephone Network
RF	Radio Frequency
Rx	Radio receiver
SANS	South African National Standard
SINAD	Signal, Noise & Distortion to Noise & Distortion ratio
SOP	Standard Output Power
SPL	Sound Pressure Level
THD	Total Harmonic Distortion
TSC	Trunk Site Controller
Tx	Radio transmitter
V	Voltage
Vp-p	Voltage peak-to-peak
VSWR	Voltage Standing Wave Ratio
W	Wattage
WiFi	Wireless fidelity
μ V	Microvolt
%	Percentage

<u>DEFINITIONS</u>	<u>DESCRIPTION</u>
GENERAL	
Angle Modulation	A term used to encompass both frequency modulation and phase modulation.
Decibel	The decibel is 1/10 of a Bel. Decibel is the logarithm of the ratio between a measured quantity and an agreed reference level.
dBc	The absolute power in decibel with reference to the carrier power.
dBm	The absolute power in decibel with reference to 1 mW.
Land Mobile Radio Services	Radio communication from fixed radio stations to mobile radio stations carried in surface vehicles or portable radio stations, and between mobile and portable radio stations.

<u>DEFINITIONS</u>	<u>DESCRIPTION</u>
Portable Radio Station	A radio station designed to be carried by or on a person.
Mobile Radio Station	A radio station designed for installation in a surface vehicle and capable of operating while the vehicle is in motion and while it is stationary.
Fixed Radio Station	It is a fixed radio station installed in an office or control room, fitted with an external antenna.
Base Station	A radio station designed to be installed in a fixed location and performing the function of a repeater/enhancer.

<u>RADIO RECEIVER</u>	
Adjacent Channel Selectivity and Desensitization Ratio	A measure of the ability of a radio receiver to receive the modulated standard input signal in the presence of modulated signals that differ in frequency from the standard input signal frequency by the spacing of one channel.
Amplitude Characteristics	The relationship between the radio frequency input level of a specified modulated signal and the audio frequency level at a radio receiver output.
Attack Time	The time required to produce an audio output level of $-0.5 \text{ dB}_{\text{SOP}}$ after application of a RF signal level, 12 dB above usable sensitivity, modulated with standard test modulation.
Audio Frequency Response	The relationship between the modulation factor of a received signal and the audio output level of the demodulated signal at various audio frequencies.
Audio Frequency Total Harmonic Distortion	The change in harmonic content of an audio signal as a result of its passing through the audio frequency and radio frequency circuits of a radio.
Blocking or Desensitisation	A reduction in the wanted audio output power of a radio receiver, or a reduction in the SINAD ratio, owing to an unwanted signal on another frequency.
Co-channel Rejection Ratio	A measure of the capability of a radio receiver to receive a wanted modulated signal without exceeding a given degradation due to the presence of an unwanted modulated signal, both signals being at the nominal frequency of the receiver.
Conducted Spurious Radiation	Its radiation components at any frequency generated by a radio receiver and radiated by the radio's antenna.
Desensitisation	Is a condition where off-channel transmitting energy passes through the front-end of the radio receiver, causing a reduction in receiver gain.
High RF Signal Level Interference	A measure of the ability of a radio receiver to oppose high RF signal levels at frequencies other than the normal frequency of the receiver.
Intermodulation Spurious Response Attenuation/Rejection	The ability of a radio receiver to receive a modulated standard input signal, in the presence of two interfering signals of which the carrier frequencies are so separated from the standard input signal frequency and from each other that n th order mixing of the two undesired signals can occur in the non-linear elements of the receiver, producing a third signal whose frequency is equal to that of the standard input signal frequency, or intermediate frequency.
Maximum Useful Output Power	The greatest average audio output power supplied to the rated load, which power does not exceed 10 % of the total harmonic distortion.
Modulation Acceptance Bandwidth	The selectivity characteristic of an angle modulated radio receiver that limits the maximum permissible modulation deviation of the radio frequency input signal that a receiver can accept, without degradation of the 12 dB SINAD ratio, when the radio frequency input signal is 6 dB greater than the usable sensitivity level.
Modulation Factor	The ratio of the maximum positive or negative peak variation of the modulating variable, to the maximum rated system-modulating variable, expressed as a

DEFINITIONS	DESCRIPTION
	percentage.
Signal, Noise & Distortion to Noise & Distortion Ratio	The ratio, expressed in decibels of the signal power, plus noise power, plus distortion power, to noise power plus distortion power produced at the output of a radio receiver resulting from a modulated signal input.
Signal to Hum and Noise Ratio	The ratio of residual receiver audio output power to standard output power.
Spurious Response Attenuation/Rejection	A measure of the ability of a radio receiver to discriminate between the standard input signal frequency and an undesired signal at any other frequency to which it is also responsive, excluding the two adjacent channels.
Squelch Closing Time	The period of time between the removal of the RF signal and the squelch closure.
Squelch Operating Threshold	The RF signal input level, modulated with standard test modulation, at which the squelch opens and closes.
Standard Output Power	An audio output level 3 dB below maximum useful output power used to define a reference level for test purposes.
Usable Sensitivity	The minimum radio frequency input signal level modulated with standard test modulation that will produce, at a radio receiver, a SINAD ratio of at least 12 dB and an audio output signal power of at least -3 dB _{OP} .
RADIO TRANSMITTER	
Adjacent Channel Power	The part of the total power output of a radio transmitter that, under defined conditions of modulation, falls within a specified bandwidth centred on the normal frequency of either of the adjacent channels.
Amplitude Modulation Hum & Noise Level	A measure of the unwanted amplitude modulation of a carrier resulting from hum and noise.
Angle Modulation Hum & Noise Ratio	The ratio of residual angle modulation to standard test modulation.
Audio Frequency Response	The relationship between the modulation factor of a transmitted signal and the input level of the modulating signal at various audio frequencies.
Audio Frequency Total Harmonic Distortion	The change in harmonic content of an audio signal as a result of its passing through the audio frequency and radio frequency circuits of a radio.
Carrier Attack Time	The time required, changing the state of a radio transmitter from standby to a state where the unmodulated carrier voltage level reaches a value 6 dB below the steady state.
Carrier Frequency Error	Is the difference between the measured unmodulated carrier frequency from the assigned frequency.
Carrier Power	The mean power available at the output terminal of a radio transmitter in the absence of modulation.
Conducted Spurious Emissions	Emissions at the antenna terminal of a radio transmitter on a frequency or frequencies that are outside the channel on which the transmitter is operating.
Extreme Transmitter Loads	Conditions under which the radio transmitter operates into an open circuit or short circuit.
Intermodulation Attenuation	The ability of a radio transmitter to attenuate signals generated in its non-linear elements by the presence of the carrier and a parasitic signal arriving at the transmitter through its antenna.
Microphone sensitivity	It is the amount of modulation that the radio transmitter produces when a specified audio signal level is present at the microphone.

<u>DEFINITIONS</u>	<u>DESCRIPTION</u>
Mismatch between Transmitter and Antenna System	A condition in which the impedance as presented to the radio transmitter by the transmission line and antenna is not the same as the designed system impedance.
Modulation Limiting (Tx deviation)	A measure of the ability of radio transmitter circuits to prevent a transmitter from producing modulation such that the modulation factor exceeds the maximum rated system modulation factor.

<u>TALK THROUGH SIGNAL</u>	
Modulation Factor Linearity	The relationship between the modulation factor of a received signal and the transmitted modulation factor.
<u>FILTERS</u>	
Duplexer/Combiner	Is a filter system providing RF isolation to allow the sharing of a single antenna for both transmission and reception.
Insertion Loss	It is the amount of loss to a signal passing through a filter at a designated frequency.
Receiver Isolation at Transmitter Frequencies	It is the ability of the duplexer/combiner to suppress the transmitter carrier power at the receiver port. It is also called the selectivity of the duplexer/combiner.
<u>ANTENNAS</u>	
Effective Radiated Power	It is the mean power radiated by the antenna in the direction of maximum radiation.
dBd	The power gain of an antenna in decibel with reference to a Dipole antenna.
<u>TRUNK CONTROL SIGNAL</u>	
Fast Frequency Shift Keying	Bit 0 = 1.8 kHz Bit 1 = 1.2 kHz

<u>AUDIO LINE BRANCHING UNIT</u>	
Common-mode Rejection Ratio	Is the ratio of the differential gain over the common-mode gain.
<u>POWER SUPPLY UNIT, DC-DC CONVERTER AND BATTERY CHARGER</u>	
Noise Voltage	Is irregular amplitude voltages superimposed on the output DC voltage line.
Output Voltage Regulation	It is the ability of a power supply device to keep the output voltage constant over a range of applied loads.
Ripple Voltage	Is AC voltage superimposed on the output DC voltage line.
Variac	A device that supply a variable AC voltage from 0 V to 260 V.
<u>ACOUSTIC</u>	
A-weighted	It is a network that weights an audio signal in a manner, which approximates to an inverted equal loudness contour (it approximates the human ear's response to sound).

<u>DEFINITIONS</u>	<u>DESCRIPTION</u>
Sound Pressure	It is the force (N) of sound on a surface area (m^2) perpendicular to the direction of the sound. SPL is express as N/m^2 or Pascal (Pa).

"PREVIEW COPY ONLY"

1. TECHNICAL SPECIFICATION

Where not specifically indicated, this specification only applies for open channel and Trunked radio systems.

1.1 Radio Receiver: 12.5 kHz channel spacing; operating frequency band 450 MHz to 470 MHz.

1.1.1 Normal condition (see clause 2.1.1)

Characteristics	Portable	Mobile & Fixed Radio Station	Base Station (Repeater)
1.1.1.1 Maximum Useful Audio Output Power	Maximum power not exceeding 10 % THD.		
1.1.1.2 Audio Frequency THD at Low Output Power Level 500 Hz & 1.0 kHz	≤ 5 %	≤ 2 %	≤ 2 %
1.1.1.3 Usable Sensitivity	≤ -115 dBm		
1.1.1.4 Squelch Operating Threshold	Open Close	- 115 dBm minimum ≤ 3 dB lower than the opening threshold	See clause 1.3.1.1 ≤ 3 dB lower than the opening threshold
1.1.1.5 Attack Time	≤ 150 ms		
1.1.1.6 Squelch Closing Time	≤ 250 ms		
1.1.1.7 Modulation Acceptance Bandwidth	≥ 3.75 kHz		
1.1.1.8 Adjacent Channel Selectivity and Desensitization Ratio	≥ 60 dB	≥ 65 dB	≥ 70 dB
1.1.1.9 Spurious Response Attenuation/Rejection	≥ 70 dB	≥ 75 dB	≥ 75 dB
1.1.1.10 Intermodulation Spurious Response Attenuation/Rejection	≥ 65 dB	≥ 65 dB	≥ 70 dB
1.1.1.11 Co-channel Rejection Ratio	≤ 12 dB		
1.1.1.12 Blocking	≥ 84 dB		
1.1.1.13 Conducted Spurious Radiation	≤ - 57 dBm		
1.1.1.14 Audio Frequency Response (on Br. scale)	300 to 900 Hz 1.1 to 2.5 kHz 3.0 kHz	+ 1 dB to - 3 dB + 1 dB to - 3 dB + 1 dB to - 4.5 dB	
1.1.1.15 Signal to Hum and Noise Ratio	Squelched Unsquelled	≥ 60 dB ≥ 39 dB	
1.1.1.16 Amplitude Characteristics	≤ 3 dB		

1.1.2 Extreme conditions (see clause 2.1.2)

Characteristics	Portable	Mobile & Fixed Radio Station	Base Station (Repeater)
1.1.2.1 Power Supply			
1.1.2.1.1 Usable Sensitivity variation	$\leq \pm 3$ dB		
1.1.2.1.2 Adjacent Channel Selectivity and Desensitisation Ratio	≥ 60 dB	≥ 65 dB	≥ 70 dB
1.1.2.2 Temperature			
1.1.2.2.1 Usable Sensitivity variation	$\leq \pm 3$ dB		
1.1.2.2.2 Adjacent Channel Selectivity and Desensitisation Ratio	≥ 60 dB	≥ 65 dB	≥ 70 dB
1.1.2.3 Selectivity at High RF Signal Level			
1.1.2.3.1 Input signal level	- 47 dBm to - 7 dBm		

1.2 **Radio Transmitter:** 12.5 kHz channel spacing; operating frequency band 450 MHz to 470 MHz.

1.2.1 Normal condition (see clause 2.1.1)

Characteristics	Portable	Mobile & Fixed Radio Station	Base Station (Repeater)
1.2.1.1 Carrier Power (conducted)	$\leq \pm 1$ dB from manufacturer's claim		
1.2.1.2 Conducted Spurious Emissions			
Operating	$\leq - 36$ dBm		
Standby	$\leq - 57$ dBm		
1.2.1.3 Carrier Frequency Error	≤ 1.5 kHz	≤ 1.5 kHz	≤ 1.0 kHz
1.2.1.4 Carrier Attack Time	≤ 100 ms		
1.2.1.5 Adjacent Channel Power	$\leq - 60$ dBc	$\leq - 70$ dBc	$\leq - 70$ dBc
	Or - 37 dBm maximum.		
1.2.1.6 Intermodulation Attenuation	n.a.	n.a.	≥ 40 dB
1.2.1.7 Modulation Limiting (Tx Deviation)			
Modulating freq. 0.3 to 2.55 kHz	2.5 kHz maximum		
3 to 6 kHz	0.75 kHz maximum at 6 kHz		
6 to 12.5 kHz	- 14 dB/octave		
1.2.1.8 CTCSS Deviation	250 Hz		
1.2.1.9 Audio Frequency THD			
500 Hz	≤ 5 %	≤ 2 %	≤ 2 %
1.0 kHz			

	Characteristics	Portable	Mobile & Fixed Radio Station	Base Station (Repeater)
1.2.1.10	Audio Frequency Response (6 dB/octave) 300 to 900 Hz 1.1 to 2.5 kHz 3.0 kHz	+ 3 dB to - 1 dB + 3 dB to - 1 dB + 4.5 dB to - 1 dB		
1.2.1.11	Angle Modulation Hum & Noise Ratio	≥ 34 dB		
1.2.1.12	Amplitude Modulation Hum & Noise Level	≤ - 34 dB		

1.2.2 Extreme conditions (see clause 2.1.2)

	Characteristics	Portable	Mobile & Fixed Radio Station	Base Station (Repeater)
1.2.2.1	Power Supply			
1.2.2.1.1	Carrier Power Variation	≤ ± 2 dB		
1.2.2.1.2	Conducted Spurious Emissions Operating Standby	≤ - 36 dBm ≤ - 57 dBm		
1.2.2.1.3	Carrier Frequency Error	≤ 1.5 kHz	≤ 1.5 kHz	≤ 1.0 kHz
1.2.2.2	Temperature			
1.2.2.2.1	Carrier Power Variation	≤ ± 2 dB		
1.2.2.2.2	Conducted Spurious Emissions Operating Standby	≤ - 36 dBm ≤ - 57 dBm		
1.2.2.2.3	Carrier Frequency Error	≤ 1.5 kHz	≤ 1.5 kHz	≤ 1.0 kHz
1.2.2.3	Antenna Terminal Loads			
1.2.2.3.1	Short Circuit and Open Circuit Carrier Power Variation	≤ ± 1 dB		

1.3 **Radio Base Station (Repeater):** 12.5 kHz channel spacing; operating frequency band 450 MHz to 470 MHz.

The receiver and transmitter specifications are referred to in clauses 1.1 and 1.2 respectively.

1.3.1 Receiver

Characteristics	Base Station (Repeater)
1.3.1.1 Squelch operating threshold calculation	
Open	- 115 dBm minus coaxial cable loss minus duplexer loss plus antenna gain.
Close	≤ 3 dB lower than the opening threshold

1.3.2 Receiver and transmitter

Characteristics	Base Station (Repeater)
1.3.2.1 Response time	≤ 300 ms

1.3.3 Talk Through Signal

Characteristics	Base Station (Repeater)
1.3.3.1 Audio input and output terminals	
Impedance	600 Ω balanced
Return Loss	≥ -25 dB
1.3.3.2 Audio Levels	
RTO & Trunking (local & interstate)	-10 dBm ± 0.5 dBm
Old Trunking Teletra system	-4 dBm ± 0.7 dBm
1.3.3.3 Audio Frequency Response (With de-emphasis and pre-emphasis)	
<u>Modulating frequency</u> 300 to 900 Hz	± 3.0 dB
1.1 to 3.0 kHz	± 3.0 dB
1.3.3.4 Audio Frequency Response (Without de-emphasis and pre-emphasis)	
<u>Modulating frequency</u> 300 to 900 Hz	± 2.0 dB
1.1 to 3.0 kHz	± 2.0 dB
1.3.3.5 Modulation Factor Linearity	
<u>Modulation</u> 0.5 kHz	0.5 kHz ± 100 Hz
1.0 kHz	1.0 kHz ± 100 Hz
1.5 kHz	1.5 kHz ± 100 Hz
2.0 kHz	2.0 kHz ± 100 Hz
2.5 kHz	2.5 kHz - 250 Hz (not to exceed 2.5 kHz)
1.3.3.6 Audio Frequency THD	≤ 5 %

1.4 **Filters**

1.4.1 Duplexer (Radio Train Order)

Characteristics	Base Station (Repeater)
1.4.1.1 Insertion Loss (Tx & Rx)	≤ 1.2 dB
1.4.1.2 Rx Isolation at Tx Frequencies	≥ 65 dB (operating band) ≥ 80 dB (single channel)
1.4.1.3 Impedance Matching, 50 Ω (all ports)	VSWR ≤ 1.5:1 Return Loss ≤ - 14 dB
1.4.1.4 * Operating Frequency Band	Receiver Transmitter 465.0500 MHz to 465.9875 MHz 455.0500 MHz to 455.9875 MHz

* Duplexer for link operation is channelized.

1.4.2 Combiner (Trunked)

Characteristics	Base Station (Repeater)
1.4.2.1 Insertion Loss - Receiver path	0 dB ± 0.5 dB
1.4.2.2 Insertion Loss - Transmit path	≤ 1.0 dB
1.4.2.3 Rx Isolation at Tx Frequencies	≥ 85 dB
1.4.2.4 Isolation between Rx ports	≥ 20 dB
1.4.2.5 Isolation between Tx ports	≥ 60 dB
1.4.2.6 Impedance Matching, 50 Ω (all ports)	VSWR ≤ 1.5:1 Return Loss ≤ - 14 dB
1.4.2.7 Operating Frequency Band	Receiver Transmitter 465.0000 MHz to 466.6375 MHz 455.0000 MHz to 456.6375 MHz

1.5 **Coaxial Cable**

Characteristics	Mobile & Fixed Radio Station	Base Station (Repeater)
1.5.1 Impedance	50 Ω	
1.5.2 Impedance matching	VSWR ≤ 1.5:1 Return Loss ≤ - 14 dB	
1.5.3 Insertion loss	≤ 1 dB	≤ 5 dB

1.6 **Antenna**

Characteristics	Various
1.6.1 Impedance	50 Ω
1.6.2 Impedance matching	VHF & UHF GSM & WIFI VSWR ≤ 1.5:1 Return Loss ≤ - 14 dB VSWR ≤ 2.0:1 Return Loss ≤ - 9.54 dB

Characteristics	Various
-----------------	---------

1.6.3	* Antenna gain Mobile Fixed station Radio link: Point to point Point to multipoint Base station	0 dBd ≤ 12 dBd 9 dBd minimum Not specified ≤ 12 dBd
1.6.4	# Antenna vertical separation	≥ 4 λ
1.6.5	* Antenna height above ground level Mobile & Fixed station Radio link: Point to point Point to multipoint Base station	10 m maximum 20 m maximum 20 m maximum 20 m maximum

Based on 20 W ERP and antennae having a Dipole as a live element. Distance measured from centre to centre of dipoles.

* Licence conditions

1.7 Transmitting Power

	Characteristics	Various
1.7.1	* Conducted power at transmitter terminal Radio link: Point to point Point to multipoint	1 W maximum 1 W maximum
1.7.2	* Effective Radiated Power (ERP) Mobile & Fixed station Radio link: Point to point Point to multipoint Base station	20 W maximum 8.2 W maximum 8.2 W maximum 20 W maximum

* Licence conditions

1.8 Receiver Desensing

	Characteristics	Various
1.8.1	Desensing	≤ 1 dB
1.8.2	Desensing at high receiving signal level (radio links only) ≥ - 100 dBm	≤ 20 dB

1.9 Audio Line Branching Unit

	Characteristics	Base Station (Repeater)
1.9.1	Audio input and output terminals impedance Return Loss	600 Ω balanced ≤ - 25 dB
1.9.2	Input and output audio signal level	- 10 dBm ± 0.5 dB
1.9.3	Audio frequency response 300 Hz to 3 kHz	± 0.5 dB
1.9.4	Audio total harmonic distortion (THD)	≤ 0.5 %
1.9.5	Audio signal to hum and noise ratio	≥ 70 dB
1.9.6	Channel cross talk	≥ 60 dB
1.9.7	Common-mode rejection ratio	≥ 60 dB at 1 kHz
1.9.8	E-signal	Up to 50 V DC, 10 mA Opto coupler

	Characteristics	Base Station (Repeater)
1.9.9	M-signal	Bi-directional polarity Up to 50 V DC, 10 mA Voltage free contact

1.10 Power Supply Unit, DC-DC Converter and Battery Charger

	Characteristics	Various
1.10.1	Operating conditions Temperature range Relative humidity	- 10 °C to 60 °C Up to 85 %
1.10.2	Input power AC Voltage Frequency DC Voltage	220 V AC \pm 10 % 50 Hz \pm 2 % Nominal \pm 10 %
1.10.3	Output voltage regulation (Intermittent & continuous)	13.8 V \pm 5 % (12 V system) 27.6 V \pm 5 % (24 V system) 55.2 V \pm 5 % (48 V system)
1.10.4	Efficiency	\geq 70 %
1.10.5	Output voltage ripple & noise	\leq 200 mVp-p (12 V system) \leq 400 mVp-p (24 V system) \leq 800 mVp-p (48 V system)
1.10.6	Radiation of spurious frequencies	\leq - 119 dBm in radio operating band
1.10.7	Desensing of receiver	\leq 1 dB
1.10.8	Load shedding (when required) Shed Restore	11.0 V (12 V system) 22.0 V (24 V system) 44.0 V (48 V system) 13.0 V (12 V system) 26.0 V (24 V system) 52.0 V (48 V system)

1.11 Trunking

1.11.1 Functional Tests

	Characteristics	Various
1.11.1.1	Registration	Register on instrument Register on trunk system
1.11.1.2	Local call to radio with the same prefix number	Establish call to instrument Establish call through the trunk system
1.11.1.3	Local call to radio with an interprefix number	Establish call to instrument Establish call through the trunk system
1.11.1.4	Local call to radio with the same prefix number using short form dialling	Establish call to instrument Establish call through the trunk system
1.11.1.5	Intersite call to radio with the same prefix number	Establish call through the trunk system
1.11.1.6	Intersite call to radio with an interprefix number	Establish call through the trunk system
1.11.1.7	Intersite call to radio with the same prefix number using short form dialling	Establish call through the trunk system

1.11.1.8	PSTN call	Establish call to instrument Establish call through the trunk system
1.11.1.9	Call the radio under test	Establish call from instrument Establish call through the trunk system
1.11.1.10	Handoff	Reregister on new control channel with Instrument Reregister on new control channel on the trunk system

1.11.2 Control Signal - Trunk Site Controller

	Characteristics	Base Station (Repeater)
1.11.2.1	FFSK level from TSC	1 Vp-p ± 0.2 Vp-p
1.11.2.2	FFSK frequency from TSC	1.2 kHz ± 100 Hz 1.8 kHz ± 100 Hz
1.11.2.3	Tx deviation at FFSK level For channel dragging problem	1.5 kHz ± 100 Hz 800 Hz ± 100 Hz
1.11.2.4	FFSK level from Rx measured at TSC (Modulation 1.5 kHz) (Modulating frequency 1.2 kHz)	1 Vp-p ± 0.2 Vp-p

1.12 Acoustical measurements

	Characteristics	Portable
1.12.1	Receiver	
	Loudspeaker sound pressure level	≥ 84 dB(A) at 300 mm
1.12.2	Transmitter	
	Transmitter deviation	Between 300 and 500 Hz from a SPL of 80 dB(A) at the microphone

1.13 Co-channel Interference

	Characteristics	Various
1.13.1	Speech	
	Level difference between signals	≥ 15 dB
1.13.2	Data (FFSK)	
	Level difference between signals	≥ 20 dB

2. METHODS OF MEASUREMENT**Applied Standard**

- 2.1 Normal condition
- | | | |
|------------------------------|---|----------------|
| Temperature | : | 23 °C ± 3 °C |
| Relative Humidity | : | 45 to 85 % |
| Lead acid battery | : | 2.3 V per cell |
| Lithium-ion battery | : | 3.6 V per cell |
| Nickel cadmium | : | 1.2 V per cell |
| Nickel Metal Hydrate battery | : | 1.2 V per cell |
| Mains | : | 220 V AC 50 Hz |
- 2.2 Extreme conditions
- | | | |
|------------------------------|---|--|
| Temperature | : | - 10 °C and 60 °C |
| Relative humidity | : | 45 to 95 % |
| Lead acid battery | : | 1.8 V minimum & 2.6 V maximum per cell |
| Lithium-ion battery | : | 3.0 V minimum & 4.2 V maximum per cell |
| Nickel Cadmium battery | : | 1.0 V minimum & 1.5 V maximum per cell |
| Nickel Metal Hydrate battery | : | 1.0 V minimum & 1.5 V maximum per cell |
| Mains | : | 220 V AC ± 10 % 50 Hz ± 2 % |
- Power Supply Systems
- | | | | | |
|-------------|---|----------------|----------------|----------------|
| 12 V system | : | Minimum 11.0 V | Nominal 13.8 V | Maximum 15.6 V |
| 24 V system | : | Minimum 22.0 V | Nominal 27.6 V | Maximum 31.2 V |
| 48 V system | : | Minimum 44.0 V | Nominal 55.2 V | Maximum 62.4 V |
- 2.3 Warm up time
As specified by the manufacturer.
- 2.4 Temperature stabilising period
One hour minimum.
- 2.5 Power source tolerance
≤ ± 3 %.
- 2.6 Standard RF Test Signal
- 2.6.1 Standard test modulation
- | | | |
|----------------------|---|---|
| Modulating frequency | : | 1.0 kHz. |
| Modulation | : | 0.5 kHz (60 % of maximum rated system deviation). |
- 2.6.2 Standard RF Signal Input Level
- 60 dBm (223.7 μV_{pd} or 447.2 μV_{EMF}).
- 2.7 Audio Output Level
SOP = - 3 dBm

2.2 Radio Receiver

2.2.1 Maximum Useful Output Power

Connect the equipment as shown below.

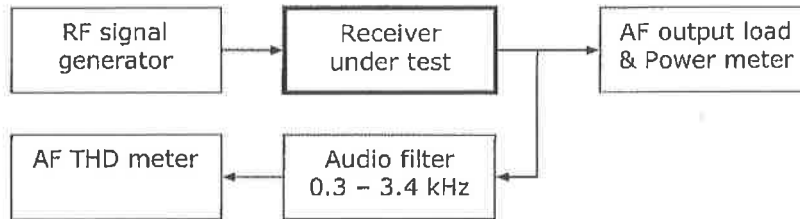

2.2.1.1 Inject a standard RF test signal from the RF signal generator.

2.2.1.2 Adjust the volume control of the radio until the THD is 10 % or the volume control reaches its maximum travel, whichever occurs first.

2.2.1.3 Measure the audio output power (MUOP).

Note: The impedance of the AF output load must be the same value as the load (loudspeaker) with which the receiver normally operates.

2.2.2 Audio frequency total harmonic distortion

Connect the equipment as shown below.

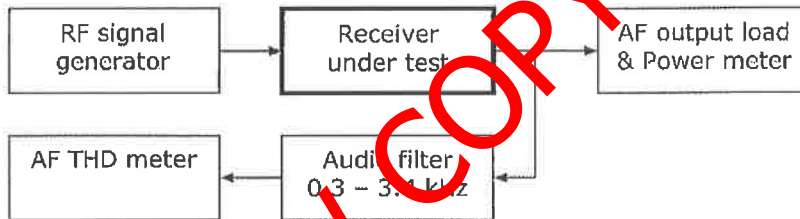

2.2.2.1 Standard measurement

2.2.2.1.1 Test 1

2.2.2.1.1.1 Inject a standard RF test signal from the RF signal generator into the receiver.

2.2.2.1.1.2 Adjust the volume control of the radio to obtain SOP.

2.2.2.1.1.3 Measure the THD.

2.2.2.1.2 Test 2

2.2.2.1.2.1 Change the modulating frequency to 500 Hz using the same modulation factor as in test 1, except that in the case of PM receivers, the modulation factor should be reduced by 50 %.

2.2.2.1.2.2 Repeat the procedure given in test 1.

2.2.2.1.2.3 Measure the THD.

2.2.2.2 600 Ω balanced line

Where a 600 Ω balanced line is provided, the THD must be measured on this line.

2.2.2.2.1 Inject a standard RF test signal from the RF signal generator into the receiver.

2.2.2.2.2 Load the line with a 600 Ω resistive load or equivalent impedance, provided by the measuring instrument.

2.2.2.2.3 Adjust the audio signal level to measure -10 dBm on the line.

2.2.2.2.4 Measure the THD.

2.2.2.2.5 Repeat the THD measurement when applying test 2.

2.2.3 Usable sensitivity

Connect the equipment as shown below.

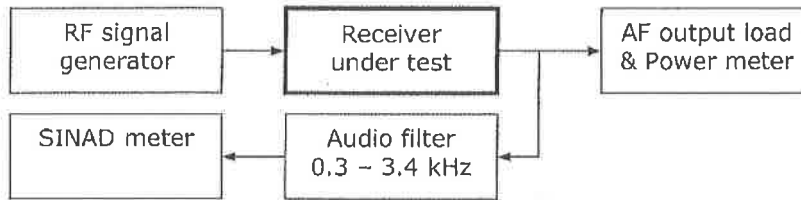

- 2.2.3.1 Adjust the RF signal generator to produce a standard RF input signal level.
- 2.2.3.2 Adjust the volume control of the radio to obtain SOP.
- 2.2.3.3 Reduce the RF signal level until the SINAD ratio is 12 dB.
- 2.2.3.4 Without readjustment of the volume control check whether the audio output level is less than $-3 \text{ dB}_{\text{SOP}}$.
- 2.2.3.5 If the audio output is less than $-3 \text{ dB}_{\text{SOP}}$, increase the RF signal level until $-3 \text{ dB}_{\text{SOP}}$ is obtained.
- 2.2.3.6 Take the RF signal output level from the signal generator at this setting as the usable sensitivity.
- 2.2.3.7 The measurement shall be made under the extreme test conditions as well. Under the extreme test conditions, the receiver audio output power shall be within $\pm 3 \text{ dB}$ of the value obtained under normal test condition.

Note: The impedance of the AF output load must be the same value as the load (loudspeaker) with which the receiver normally operates.

2.2.4 Squelch operating threshold

Connect the equipment as shown below.

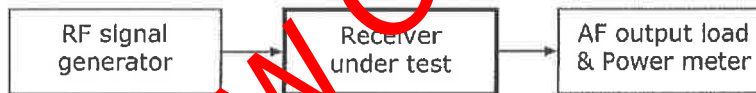

- 2.2.4.1 Apply a standard RF test signal to the receiver under test and adjust the volume control of the radio to obtain SOP.
- 2.2.4.2 Reduce the RF signal level **slowly** until the squelch closes and record this RF signal level as the squelch closing level in dBm.
- 2.2.4.3 Increase the RF signal level **slowly** until the squelch opens and record this RF signal level as the squelch opening level in dBm.

2.2.5 Attack time

Connect the equipment as shown below.

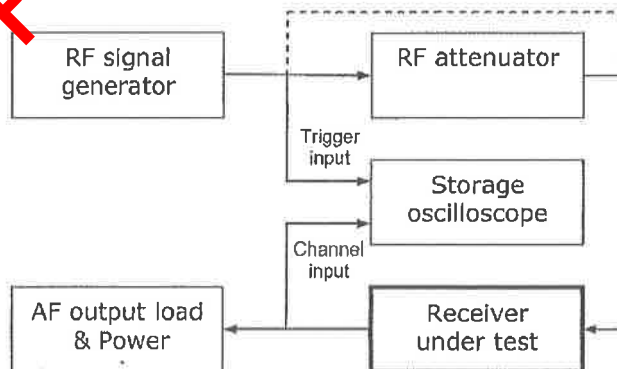

- 2.2.5.1 Apply a standard RF test signal to the receiver under test.

- 2.2.5.2 Adjust the volume control of the radio to obtain SOP.
- 2.2.5.3 Determine the usable sensitivity as described in clause 2.2.3.
- 2.2.5.4 Adjust the squelch to open at a RF signal level of -115 dBm, measured at the antenna terminal.
- 2.2.5.5 Set the RF signal level from the signal generator to 0 dBm.
- 2.2.5.6 Set the value of the RF attenuator to decrease the signal level to 12 dB above the usable sensitivity level, measured at the antenna terminal and switch the output of the signal generator off.
- 2.2.5.7 Set the storage oscilloscope to single sweep operation.
- 2.2.5.8 Switch the RF output on and measure the time required for the audio output to reach -0.5 dB_{SOP}.
- 2.2.5.9 Repeat the measurement three times and take the average of the three measurements as the receiver attack time.

2.2.6 Squelch Closing Time

Connect the equipment as shown below.

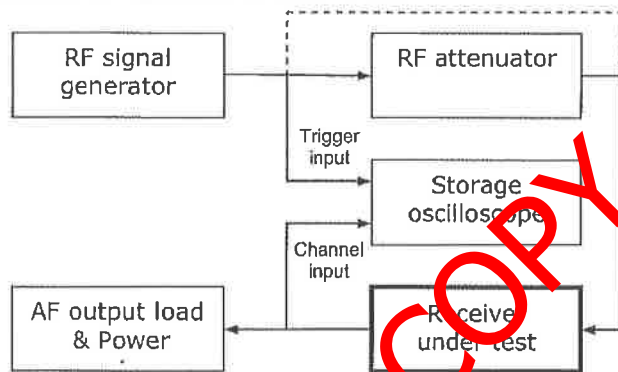

- 2.2.6.1 Apply a standard RF test signal to the receiver under test.
- 2.2.6.2 Adjust the volume control of the radio to obtain SOP.
- 2.2.6.3 Determine the usable sensitivity as described in clause 2.2.3.
- 2.2.6.4 Adjust the squelch to open at a RF signal level of -115 dBm, measured at the antenna terminal.
- 2.2.6.5 Set the RF signal level from the signal generator to 0 dBm.
- 2.2.6.6 Set the value of the RF attenuator to decrease the signal level to 12 dB above the usable sensitivity level, measured at the antenna terminal.
- 2.2.6.7 Set the storage oscilloscope to single sweep operation.
- 2.2.6.8 Switch the output of the signal generator off and measure the time required for the audio output to be reduced by 10 dB from the SOP value.
- 2.2.6.9 Repeat the measurement three times and take the average of the three measurements as the squelch closing time.

2.2.7 Modulation acceptance bandwidth

Connect the equipment as shown below.

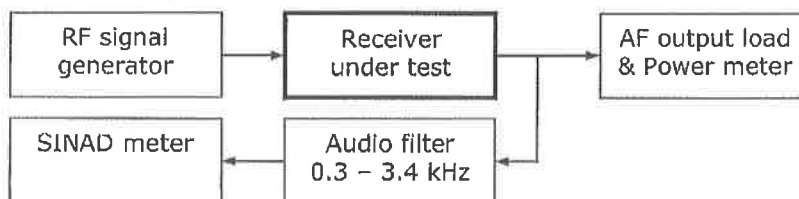

- 2.2.7.1 Apply a standard RF test signal to the receiver under test.
- 2.2.7.2 Adjust the receiver volume control to obtain SOP.

- 2.2.7.3 Reduce the RF signal level until the SINAD ratio is 12 dB. :
- 2.2.7.4 Increase the RF signal level by 6 dB. :
- 2.2.7.5 Increase the modulation factor until the SINAD ratio is again 12 dB.
- 2.2.7.6 Record this value of the modulation factor as the modulation acceptance bandwidth.

2.2.8 Adjacent channel selectivity and desensitization ratio

Connect the equipment as shown below.

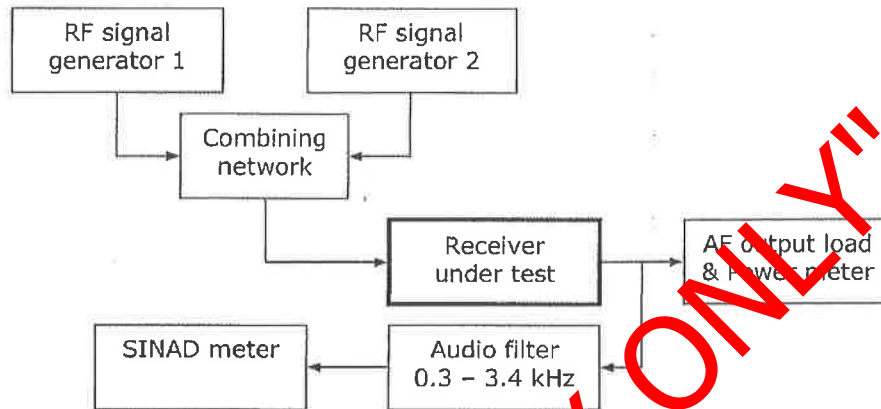

- 2.2.8.1 Switch the RF signal output of signal generator 2 off.
- 2.2.8.2 RF signal generator 1:
- 2.2.8.2.1 Apply a standard RF test signal to the receiver under test.
- 2.2.8.2.2 Adjust the volume control of the radio to obtain SOP.
- 2.2.8.2.3 Reduce the RF signal until the SINAD ratio is 12 dB (wanted signal).
- 2.2.8.2.4 Note this RF signal level.
- 2.2.8.3 RF signal generator 2:
- 2.2.8.3.1 Switch the RF signal output on (unwanted signal).
- 2.2.8.3.2 Modulate the RF signal with 400 Hz at the standard modulation factor.
- 2.2.8.3.3 Set the frequency (unwanted signal) to a frequency one-channel width above the assigned frequency (wanted signal).
- 2.2.8.3.4 Adjust the RF signal level such that the SINAD ratio is degraded to 6 dB.
- 2.2.8.3.5 Note the RF signal level.
- 2.2.8.3.6 Repeat for the unwanted signal set to a frequency one-channel width below the assigned frequency.
- 2.2.8.4 Calculate the difference between the unwanted and wanted signal levels in dB, as the adjacent channel selectivity and desensitization ratio.
- 2.2.8.5 Take the worst case of the two measurements as the result.
- 2.2.8.6 The measurements shall be made under the extreme test conditions as well.

2.2.9 Spurious response attenuation/rejection

Connect the equipment as shown below.

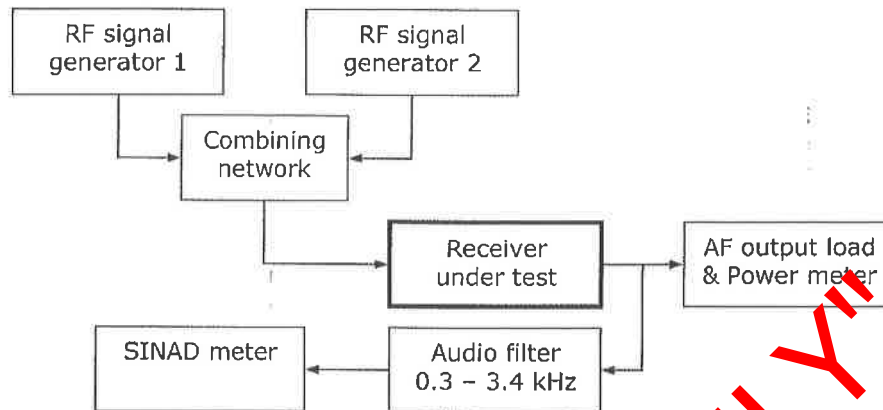

- 2.2.9.1 Switch the RF signal output of signal generator 2 off.
- 2.2.9.2 RF signal generator 1:
- 2.2.9.2.1 Adjust the RF signal generator to produce a standard RF test signal.
- 2.2.9.2.2 Adjust the volume control of the radio to obtain SCL.
- 2.2.9.2.3 Reduce the RF signal to the receiver until the SINAD ratio is 12 dB.
- 2.2.9.3 RF signal generator 2:
- 2.2.9.3.1 Switch the RF signal output on and adjust the signal level to 80 dB (portable) or 85 dB (mobile and base) higher than that of signal generator 1.
- 2.2.9.3.2 Modulate the RF signal with 400 Hz at standard modulation factor.
- 2.2.9.3.3 Slowly sweep the carrier frequency over the range 100 kHz to 1 GHz in 12.5 kHz steps (channels) excluding the assigned channel and the two adjacent channels.
- 2.2.9.3.4 When the receiver is responsive to a spurious signal, adjust the RF signal level until the SINAD ratio is 6 dB.
- 2.2.9.4 Note the frequency and the RF signal levels of the two signal generators and take the difference between the two levels expressed in dB as the measure of the spurious response attenuation at that frequency.
- Note: Ensure that the measured response is not caused by spurious signals from the RF signal generators or Intermodulation products between the two signals.

2.2.10 Intermodulation spurious response attenuation/rejection

Connect the equipment as shown below.

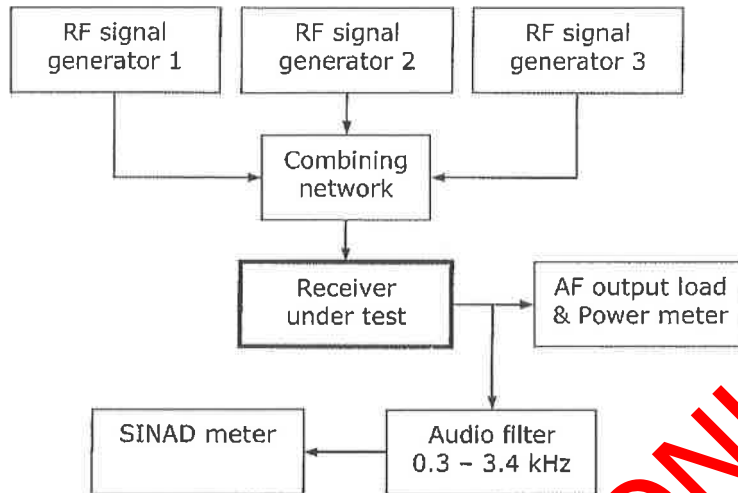

- 2.2.10.1 Switch the RF signal output of signal generators 2 & 3 off.
- 2.2.10.2 RF signal generator 1:
- 2.2.10.2.1 Adjust the RF signal generator to produce a standard RF test signal.
- 2.2.10.2.2 Adjust the volume control of the radio to obtain SOP.
- 2.2.10.2.3 Reduce the RF signal to the receiver until the SINAD ratio is 12 dB.
- A. 2.2.10.3 RF signal generator 2:
- 2.2.10.3.1 Adjust the unmodulated frequency of the RF signal generator to the second adjacent channel above the nominal carrier frequency.
- 2.2.10.4 RF signal generator 3:
- 2.2.10.4.1 Modulate the RF signal with 400 Hz at standard modulation factor.
- 2.2.10.4.2 Adjust the frequency of the RF signal generator to the fourth adjacent channel above the nominal carrier frequency.
- 2.2.10.5 Switch the RF signal output of signal generators 2 & 3 on.
- 2.2.10.6 Maintain the outputs of RF signal generators 2 & 3 at equal levels.
- 2.2.10.7 Adjust the RF signal levels to reduce the SINAD ratio to 6 dB.
- 2.2.10.8 Adjust the frequency of RF signal generator 3 slightly to produce the maximum interfering signal.
- 2.2.10.9 Note the difference in dB between the RF signal output level from RF signal generator 1 and the RF signal output level from RF signal generators 2 & 3.
- B. 2.2.10.10 Repeat these measurements with RF signal generators 2 & 3 adjusted to the fourth adjacent and eighth adjacent channels above the nominal carrier frequency.
- C. 2.2.10.11 The measurements described in A & B shall be repeated with RF signal generators 2 & 3 set to the appropriate channels below the nominal frequency of the receiver.
- 2.2.10.12 Record the worst ratio in dB as the measure of the intermodulation spurious response attenuation.

2.2.11 Co-channel rejection ratio

Connect the equipment as shown below.

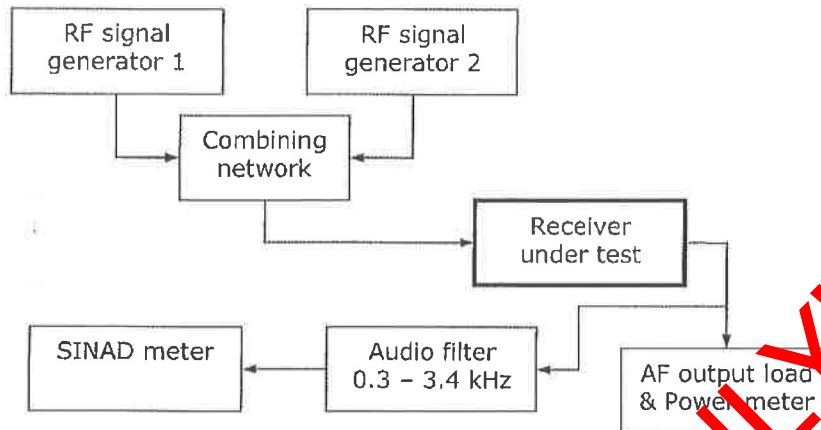

- 2.2.11.1 Switch the RF signal output of signal generator 2 off.
- 2.2.11.2 RF signal generator 1:
- 2.2.11.2.1 Adjust the RF signal generator to produce a standard RF test signal.
- 2.2.11.2.2 Adjust the volume control of the radio to obtain SOP.
- 2.2.11.2.3 Reduce the RF signal until the SINAD ratio is 12 dB (wanted signal).
- 2.2.11.3 RF signal generator 2:
- 2.2.11.3.1 Switch the RF signal output on (unwanted signal).
- 2.2.11.3.2 Set the frequency to the assigned receiver frequency.
- 2.2.11.3.3 Modulate the RF signal with 400 Hz at standard modulation factor.
- 2.2.11.3.4 Adjust the RF signal level such that the SINAD ratio is reduced to 6 dB.
- 2.2.11.4 Record the co-channel rejection ratio as the difference in dB, between the wanted and unwanted signal levels.
- 2.2.11.5 Repeat the measurement with signal generator 2 set to frequencies 1.5 kHz and 3.0 kHz above and below the assigned frequency.
- 2.2.11.6 The highest value of the five measurements shall be recorded as the co-channel rejection ratio.

2.2.12 Blocking or Desensitisation

Connect the equipment as shown below.

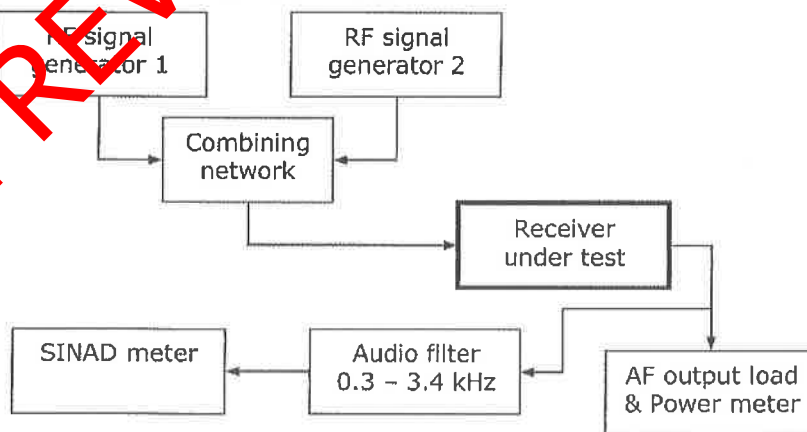

- 2.2.12.1 Switch the RF signal output of signal generator 2 off.

- 2.2.12.2 RF signal generator 1:

- 2.2.12.2.1 Adjust the RF signal generator to produce a standard RF test signal.
- 2.2.12.2.2 Adjust the volume control of the radio to obtain SOP.
- 2.2.12.2.3 Reduce the RF signal until the SINAD ratio is 12 dB (wanted signal).
- 2.2.12.3 RF signal generator 2:
- 2.2.12.3.1 Switch the unmodulated RF signal output on (unwanted signal).
- 2.2.12.3.2 Set the RF signal to a level 84 dB higher than signal generator 1.
- 2.2.12.3.3 Vary the frequency from 1 MHz to 10 MHz on either side of the assigned carrier frequency.
- 2.2.12.4 Monitor the variation in the audio output level and the SINAD ratio.
- 2.2.12.5 Record the difference in dB between the signal output levels from the two RF signal generators at which the audio output power decreased with 3 dB or the SINAD ratio decreases to 6 dB, whichever occurs first.

Note: Ensure that the measured response is not caused by spurious signals from the RF signal generators.

2.2.13 Conducted Spurious radiation

Connect the equipment as shown below.

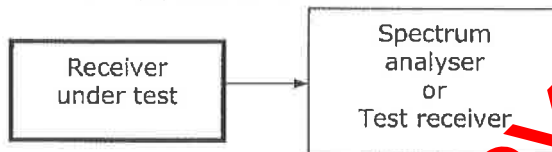

- 2.2.13.1 Switch the receiver on.
- 2.2.13.2 The receiver must be in standby mode.
- 2.2.13.3 Slowly sweep the measuring instrument over the range 9 kHz to 4 GHz.
- 2.2.13.4 Record the frequencies and measure the absolute levels of the conducted spurious radiation.

2.2.14 Audio frequency response

Connect the equipment as shown below.

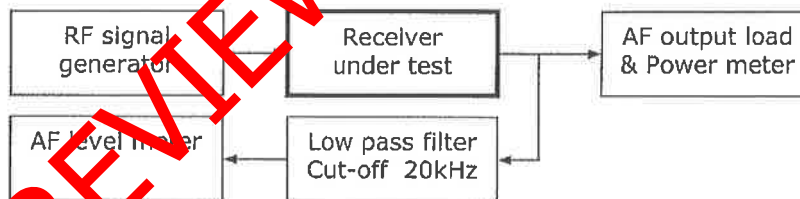

- 2.2.14.1 Standard measurement
- 2.2.14.1.1 Adjust the RF signal generator to produce a standard RF test signal and inject it into the receiver.
- 2.2.14.1.2 Adjust the volume control of the radio to obtain SOP.
- 2.2.14.1.3 Adjust the modulation of the RF signal generator to 20 % of the maximum system deviation.
- 2.2.14.1.4 While keeping the modulation factor constant vary the modulating frequency over the range 300 Hz to 3 kHz.
- 2.2.14.1.5 Record the variation of the audio output power over this range in dB with reference to the corresponding level at 1 kHz.
- 2.2.14.1 600 Ω balanced line
- Where a 600 Ω balanced line is provided, the audio frequency response must be measured on this line.
- 2.2.14.2.1 Inject a standard RF test signal from the RF signal generator into the receiver.
- 2.2.14.2.2 Load the line with a 600 Ω resistive load or equivalent impedance, provided by the measuring instrument.

- 2.2.14.2.3 Adjust the audio signal level to measure - 10 dBm on the line.
- 2.2.14.2.4 Proceed with clauses 2.2.14.1.3 and 2.2.14.1.5.

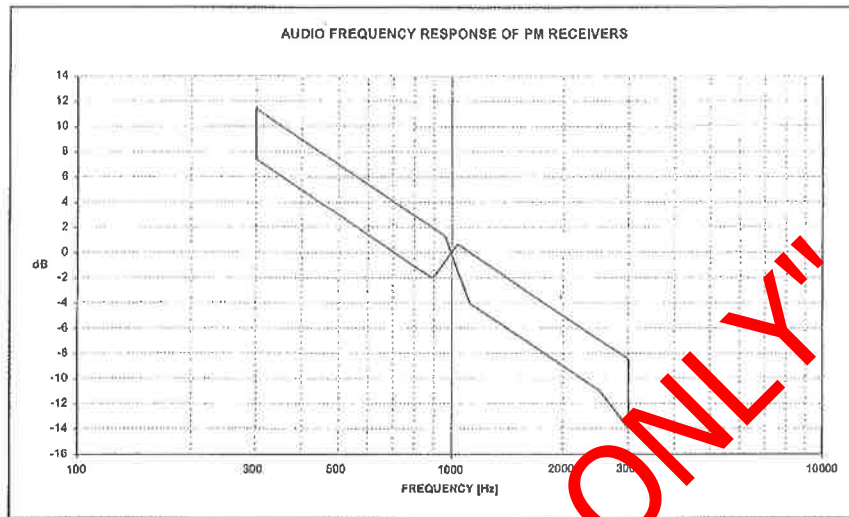

6dB/octave slope

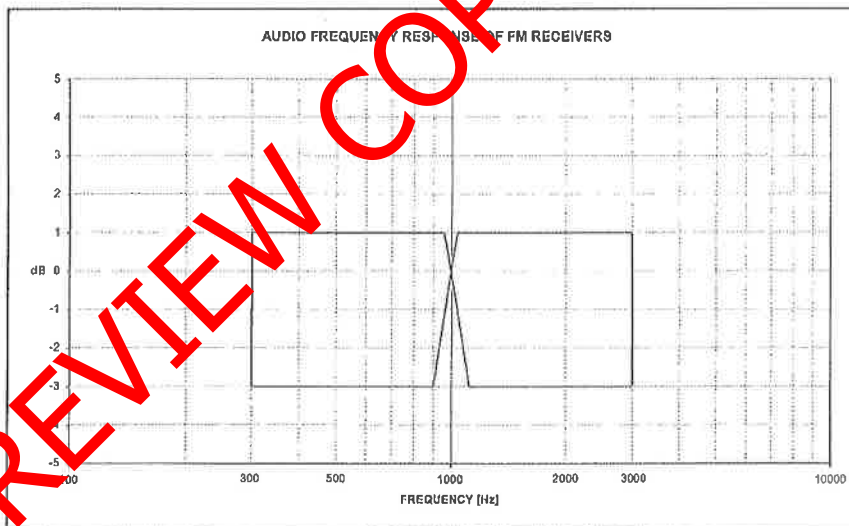

"PREVIEW COPY ONLY"

2.2.15 Signal to hum and noise ratio

Connect the equipment as shown below.

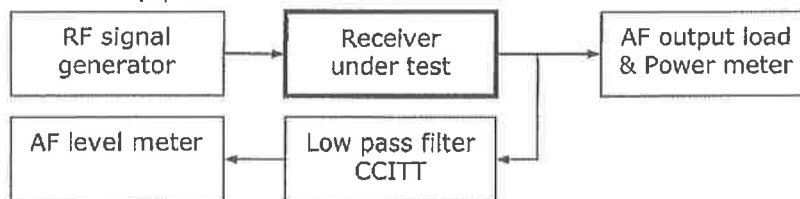

- 2.2.15.1 Select the CCITT filter (low pass filter).
- 2.2.15.2 Adjust the RF signal generator to produce a standard RF test signal.
- 2.2.15.3 Adjust the volume control of the radio to obtain SOP.

- 2.2.15.4 Adjust the squelch to its minimum (unsquelched).
- 2.2.15.5 Remove the modulation and measure the audio output power.
- 2.2.15.6 Adjust the squelch to its maximum (squelched).
- 2.2.15.7 If the receiver remains unsquelched remove the RF signal.
- 2.2.15.8 Measure the audio output power.
- 2.2.15.9 Record the ratio in dB between the audio output powers without modulation, and the SOP level as the signal to hum and noise ratio.

2.2.16 Amplitude characteristics

Connect the equipment as shown below.

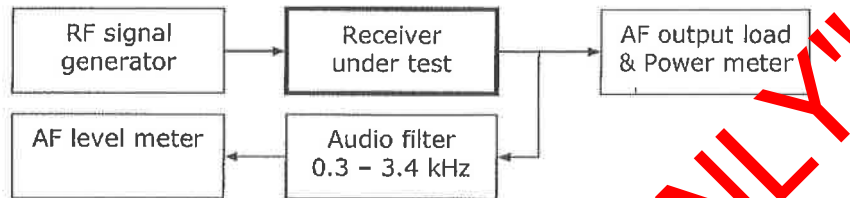

- 2.2.16.1 Adjust the RF signal generator to produce a standard RF test signal.
- 2.2.16.2 Increase the RF output signal level to -13 dBm.
- 2.2.16.3 Adjust the volume control of the radio to obtain SOP.
- 2.2.16.4 Decrease the RF signal output level from -13 dBm to -107 dBm and measure the change in the audio output level in dB.

2.2.17 High RF signal level interference

Connect the equipment as shown below.

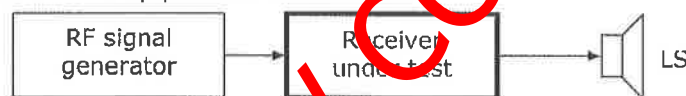

- 2.2.17.1 Set the radio to operate on the lowest channel.
- 2.2.17.2 Adjust the RF signal generator to produce a standard RF test signal.
- 2.2.17.3 Adjust the squelch to open at a RF signal level of -115 dBm.
- 2.2.17.4 Increase the RF signal level to -7 dBm.
- 2.2.17.5 Scan the frequencies of 132 channels above the receiving channel, excluding the assigned channel and the adjacent channels.
- 2.2.17.6 Record the channel and the RF signal level, at which the squelch opens in the window of -47 dBm to -7 dBm.
- 2.2.17.7 Set the radio to operate on the highest channel.
- 2.2.17.8 Scan the frequencies of 132 channels below the receiving channel, excluding the assigned channel and the adjacent channels.
- 2.2.17.9 Record the channel and the RF signal level, at which the squelch opens in the window of -47 dBm to -7 dBm.

Note: Where the interfering channels correspond with the intermodulation free channel groups, interference could occur.

Intermodulation free channel groups

High site channels

Duplex, 5th order, 132 channels

Group A	1	2	6	8	22	37	54	61	79	80	88	91	101	124	129
---------	---	---	---	---	----	----	----	----	----	----	----	----	-----	-----	-----

Duplex, 5th order, 132 channels

Group B	3	4	7	23	45	73	75	85	96	102	120	128
---------	---	---	---	----	----	----	----	----	----	-----	-----	-----

Duplex, 5th order, 132 channels

Group C	16	41	57	59	74	78	83	110	122	123	130
---------	----	----	----	----	----	----	----	-----	-----	-----	-----

Duplex, 5th order, first 52 channels

Group D	17	18	21	31	40	46	48
---------	----	----	----	----	----	----	----

Duplex, 5th order, first 52 channels

Group E	19	28	32	43	44	49	51
---------	----	----	----	----	----	----	----

Duplex, 5th order, first 52 channels

Group F	29	30	35	42	50	52
---------	----	----	----	----	----	----

Duplex, 5th order, first 52 channels

Group G	11	14	24	26
---------	----	----	----	----

Duplex, 5th order, first 52 channels

Group H	34	36	47
---------	----	----	----

Shunting channels

Simplex, 5th order, last 80 channels

Group A	53	56	60	71	97	99	109	118	126	131	132
Group B	55	58	62	63	72	84	112	125			
Group C	64	67	69	76	95	101	116	127			
Group D	68	77	82	90	107	113	114	117			
Group E	65	66	70	81	100	121					
Group F	81	87	89	92	104	108					

"PREVIEW COPY ONLY"

2.3 Radio Transmitter

2.3.1 Carrier power (conducted)

Connect the equipment as shown below.



2.3.1.1 Measure the carrier power in the absence of modulation.

2.3.1.2 The measurement shall be made under the extreme test conditions as well.

2.3.2 Conducted spurious emissions

Connect the equipment as shown below.

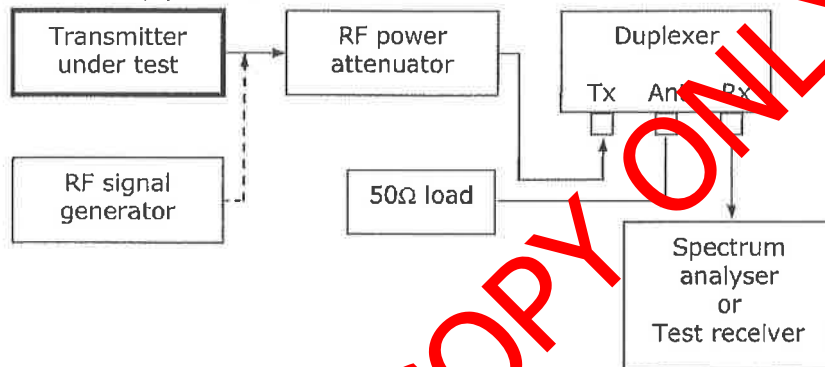

2.3.2.1 The duplexer must be tuned to the operating band. See specifications in clause 1.4.1.

2.3.2.2 The value of the RF attenuator (including the duplexer) must be such to limit the carrier level at the spectrum analyser/test receiver to approximately -60 dBm.

2.3.2.3 With the transmitter transmitting an unmodulated carrier, measure and record the frequencies and absolute levels of the conducted spurious up to the 5th harmonic.

2.3.2.4 Replace the transmitter with the RF signal generator.

2.3.2.5 Tune the RF signal generator to the recorded frequency and adjust the output level to obtain the recorded level of the spectrum analyser/test receiver.

2.3.2.6 Record the output level of the RF signal generator as the conducted spurious emission at that specific frequency.

2.3.2.7 Repeat 2.3.2.5 & 2.3.2.6 for all the other spurious emissions detected.

2.3.2.8 Remove the RF attenuator and duplexer and repeat the measurements when the transmitter is in the standby mode.

2.3.2.9 The measurements shall be made under the extreme test conditions as well.

2.3.1.10 With the above circuit the reverse channels can also be tested.

2.3.3 Carrier frequency error

Connect the equipment as shown below.

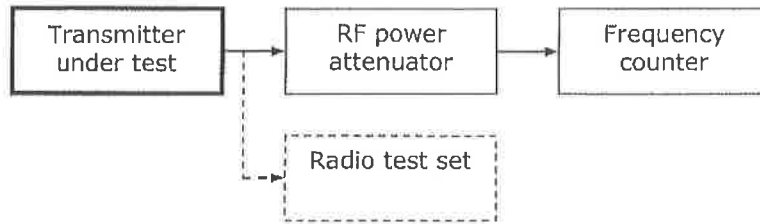

- 2.3.3.1 Measure the carrier frequency in the absence of modulation.
- 2.3.3.2 Repeat the measurement on each channel on which the transmitter is equipped to operate.
- 2.3.3.3 Calculate the carrier frequency error as the difference between the assigned frequency and the measured frequency. (Some test instruments can be set to measure the frequency error directly).
- 2.3.3.4 Record the worst case as the result.
- 2.3.3.5 The measurement shall be made under the extreme test conditions as well.

2.3.4 Carrier attack time

Connect the equipment as shown below.

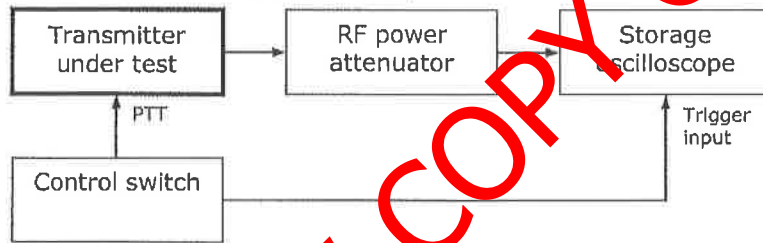

- 2.3.4.1 Set the storage oscilloscope to single sweep operation.
- 2.3.4.2 Operate the control switch and measure the time interval for the unmodulated carrier voltage level to reach a value 6 dB (50%) below the steady state level.

2.3.5 Adjacent channel power

Connect the equipment as shown below.

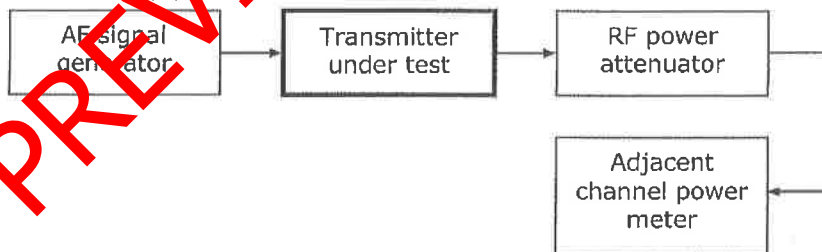

- 2.3.5.1 Ensure that the modulation limiting (Tx deviation) is set correctly (see clause 2.3.7).
- 2.3.5.2 Measure the unmodulated carrier power level.
- 2.3.5.3 Modulate the transmitter with a 1 250 Hz signal at a level 20 dB greater than that required to produce the standard test modulation factor.
- 2.3.5.4 Measure the mean power produced by the modulation, hum and noise of the transmitter in the adjacent channels.
- 2.3.5.5 Express the adjacent channel power in dB with reference to the measured carrier power.
- 2.3.5.6 Record the worst ratio as the measure of the adjacent channel power.

Or: When the measured level does not comply with the specification:

The adjacent channel power not to exceed a level of -37 dBm irrespective of the carrier power level.

2.3.6 Intermodulation attenuation (fixed radio stations only)

Method A: Connect the equipment as shown below.

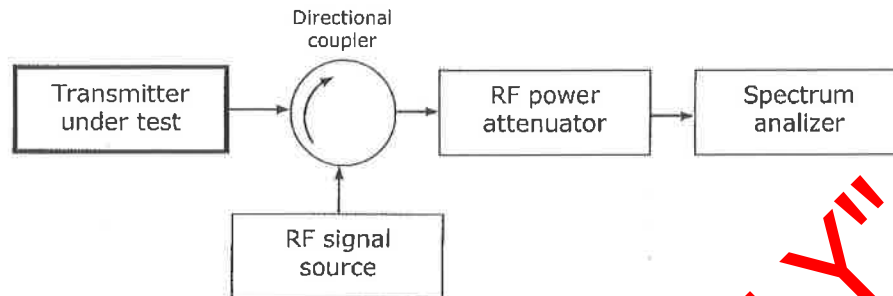

- 2.3.6.1 Set the unmodulated signal level from the RF signal source to give a level, measured at the transmitter output terminal, 30 dB below the output carrier level.
- 2.3.6.2 With the transmitter transmitting an unmodulated carrier, vary the frequency of the RF signal source between 50 kHz and 100 kHz, above and below the carrier frequency.
- 2.3.6.3 Measure the levels of the Intermodulation component.
- 2.3.6.4 The Intermodulation attenuation is expressed as the ratio of the carrier level to the level of the largest Intermodulation product (third order) observed.
- 2.3.6.5 Record the worst case as the result.

Note: Ensure that the measured response is not caused by spurious signals from the RF signal source.

Method B: Connect the equipment as shown below.

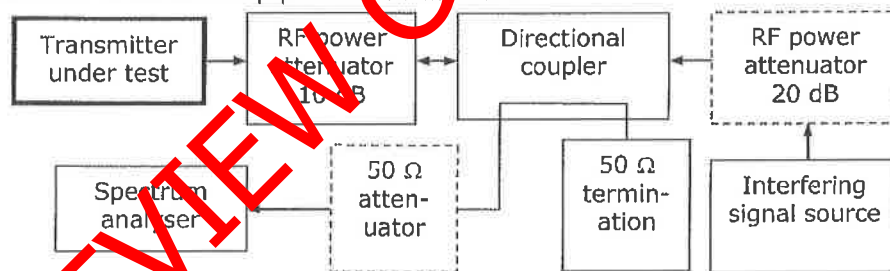

- 2.3.6.6 The coupling between the transmitter under test and the 10 dB RF power attenuator must be as short as possible to minimize mismatching.
- 2.3.6.7 The directional coupler must have an insertion loss of ≤ 1 dB, directivity of ≥ 20 dB and sufficient bandwidth.
- 2.3.6.8 The transmitter under test and the interfering signal source must have sufficient physical separation to prevent the measurement being influenced by direct radiation.
- 2.3.6.9 The RF signal level from the interfering signal source must have the same level as that of the transmitter. Alternatively, the RF signal level from the interfering signal source must be 20 dB lower than that of the transmitter – omit the 20 dB RF power attenuator.
- 2.3.6.10 The transmitter under test shall be unmodulated.
- 2.3.6.11 The spectrum analyser must be adjusted to give a maximum indication (amplitude) with a frequency scan of 500 kHz.
- 2.3.6.12 The interfering signal source must be unmodulated and the frequency must be varied between 50 kHz to 100 kHz above and below the frequency of the transmitter under test.

2.3.6.13 Measure the levels of the Intermodulation components on the spectrum analyser and determine the ratio of the carrier level to the level of the largest Intermodulation product (third order) observed, in dB.

2.3.6.14 Record the worst case as the result.

Note: Ensure that the measured response is not caused by spurious signals from the RF signal source.

2.3.7 Modulation limiting (Tx deviation)

Connect the equipment as shown below.

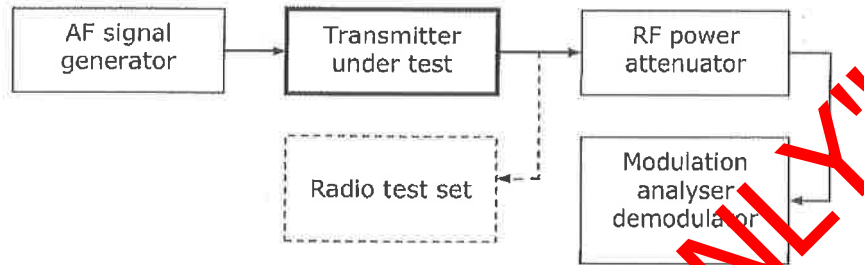

2.3.7.1 Ensure that the maximum deviation is set correctly and according to the manufacturer's procedure.

2.3.7.2 Apply electrically a 1 kHz audio test signal to the microphone input of the transmitter at a level sufficient to produce the standard test modulation level.
(When an electrical input signal cannot be applied this may be replaced by an acoustical signal.)

2.3.7.3 Set the audio filter of the modulation analyser to Low Pass cut-off 15 kHz or 20 kHz.

2.3.7.4 Note the level of the audio test signal (reference).

2.3.7.5 Modulating frequency 0.3 kHz to 2.55 kHz:

2.3.7.5.1 Increase the audio test signal with 20 dB. Ensure that the measured deviation equals the maximum system deviation.

2.3.7.5.2 Without changing the audio input signal level vary the modulating frequency between 300 Hz and 2.55 kHz.

2.3.7.5.3 Record the largest positive or negative peak deviation obtained, as the modulation limit.

2.3.7.6 Modulating frequency 2.55 kHz to 6.0 kHz:

2.3.7.6.1 Decrease the audio test signal to obtain the standard test modulation factor (reference).

2.3.7.6.2 Without changing the audio input signal level vary the modulating frequency between 2.55 kHz and 6.0 kHz.

2.3.7.6.3 Record the largest positive or negative peak deviation obtained, as the modulation limit for the specific modulating frequency band.

Note: The deviation produced by the modulating frequencies between 2.55 kHz and 6.0 kHz must not exceed that of the deviation produced by the modulating frequency 2.55 kHz.

2.3.7.7 Modulating frequency 6.0 kHz to 12.5 kHz:

2.3.7.7.1 Obtain the standard test modulation factor (reference).

2.3.7.7.2 Without changing the audio input signal level vary the modulating frequency between 6.0 kHz and 12.5 kHz.

2.3.7.7.3 Record the decrease in the positive or negative peak deviation, as the modulation limit for the specific modulating frequency band.

Note: Care must be taken not to generate hum when the audio signal is connected electrically.

It must be ensured that the acoustical audio source has a flat response throughout the bandwidth.

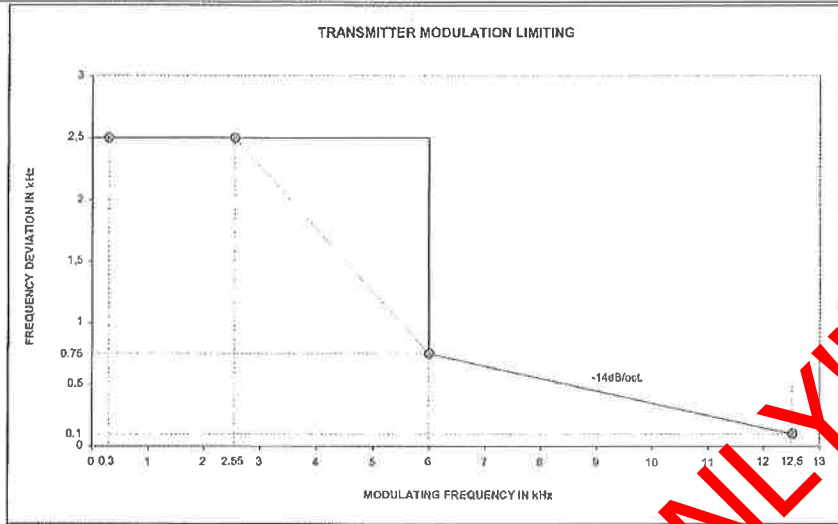

2.3.8 CTCSS deviation

Connect the equipment as shown below.

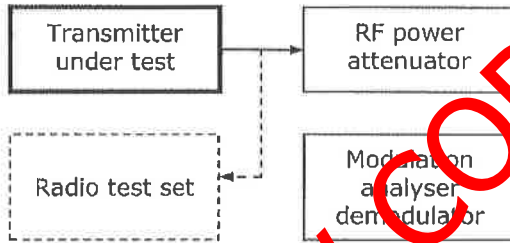

- 2.3.8.1 Select the CTCSS frequency and activate the function.
- 2.3.8.2 Set the audio filter of the modulation analyser to Low Pass cut-off 15 kHz or 20 kHz.
- 2.3.8.3 In the absence of an audio input signal (modulating signal) transmit a carrier.
- 2.3.8.4 Measure and record the deviation of the sub-audible tone.

2.3.9 Audio frequency total harmonic distortion (THD)

Connect the equipment as shown below.

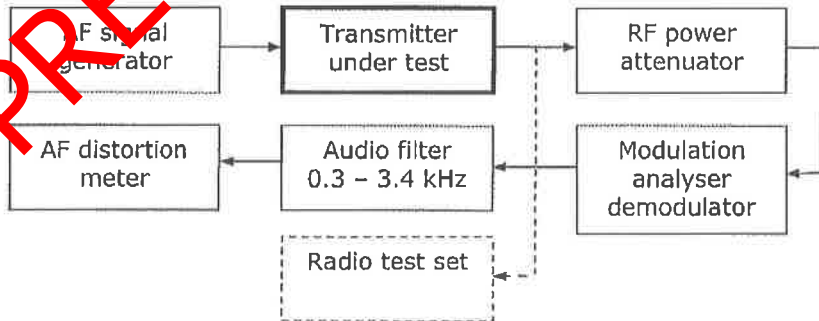

- 2.3.9.1 Standard measurement
 - 2.3.9.1.1 Apply electrically a 1 kHz audio test signal to the microphone input of the transmitter at a level sufficient to produce the standard test modulation factor.
 - 2.3.9.1.2 Record the distortion obtained.
 - 2.3.9.1.3 Adjust the audio signal generator frequency to 500 Hz.

2.3.9.1.4 Set the audio output signal at a level sufficient to produce the standard test modulation factor.

2.3.9.1.5 Record the distortion obtained.

Note: Care must be taken not to generate hum when the audio signal is connected electrically.

2.3.9.2 600 Ω balanced line input

Where a 600 Ω balanced line is provided, the THD must be measured on this line.

2.3.9.2.1 Load the line with a 600 Ω resistive load or equivalent impedance, provided by the test instrument.

2.3.9.2.2 Inject a 1 kHz audio test signal into the line at a level of -10 dBm.

2.3.9.2.3 Ensure that the transmitting signal deviation comply with the standard test modulation factor.

2.3.9.2.4 Measure and record the THD.

2.3.10 Audio frequency response

Connect the equipment as shown below.

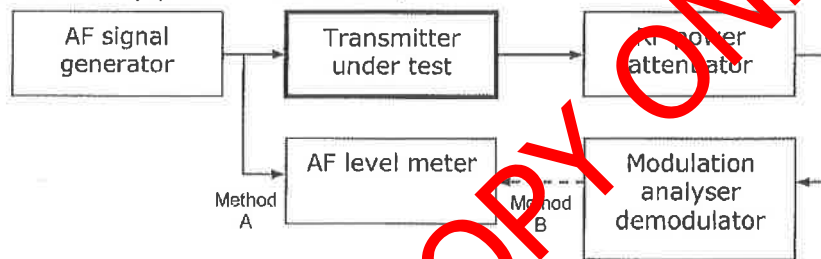

2.3.10.1 Standard measurement

Method A.

2.3.10.1.1 Apply electrically a 1 kHz audio test signal to the microphone input of the transmitter at a level sufficient to obtain 20 % of the maximum system deviation.

2.3.10.1.2 Select the low pass filter (cut-off 20 kHz) at the modulation analyser.

2.3.10.1.3 Vary the modulating frequency (audio signal) from 300 Hz to 3 kHz.

2.3.10.1.4 Adjust the modulating frequency level (audio signal) to maintain the modulation factor constant.

2.3.10.1.5 Record the variation in the audio output level of the AF signal generator in dB with reference to the corresponding level at 1 kHz.

Method B.

2.3.10.1.6 Apply electrically a 1 kHz audio test signal to the microphone input of the transmitter at a level sufficient to obtain 20 % of the maximum system deviation.

2.3.10.1.7 Select the low pass filter (cut-off 20 kHz) at the modulation analyser.

2.3.10.1.8 Keeping the audio signal level constant, vary the frequency from 300 Hz to 3 kHz.

2.3.10.1.9 Record the variation in the audio output level from the demodulator in dB with reference to the corresponding level at 1 kHz.

Note: The + and – signs must be inverted to be able to apply the graph.

2.3.10.2 600 Ω balanced line input

Where a 600 Ω balanced line is provided, the audio frequency response must be measured on this line.

2.3.10.2.1 Load the line with a 600 Ω resistive load or equivalent impedance, provided by the test instrument.

2.3.10.2.2 Inject a 1 kHz audio test signal into the line at a level of -10 dBm.

2.3.10.2.3 Ensure that the transmitting signal deviation comply with the standard test modulation factor.

2.3.10.2.4 Reduce the audio signal level to obtain 20 % of the maximum system deviation.

2.3.10.2.5 Proceed with test method A (2.3.10.1.2 to 2.3.10.1.5) or test method B (2.3.10.1.7 to 2.3.10.1.9)

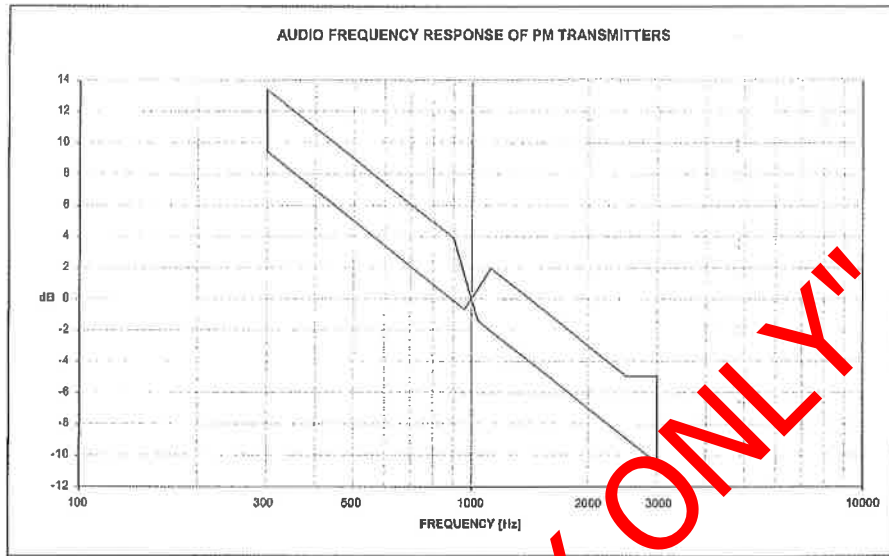

6dB/octave slope

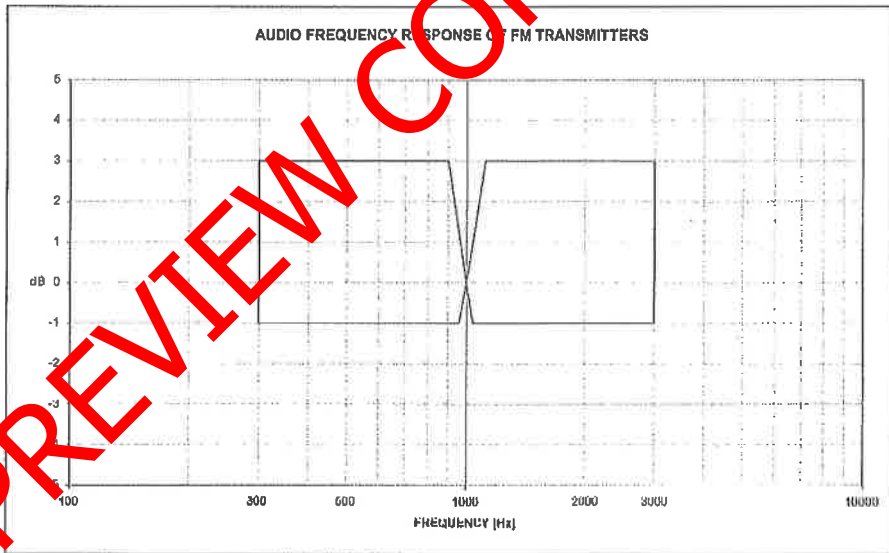

2.3.11 Angle modulation hum and noise ratio

Connect the equipment as shown below.

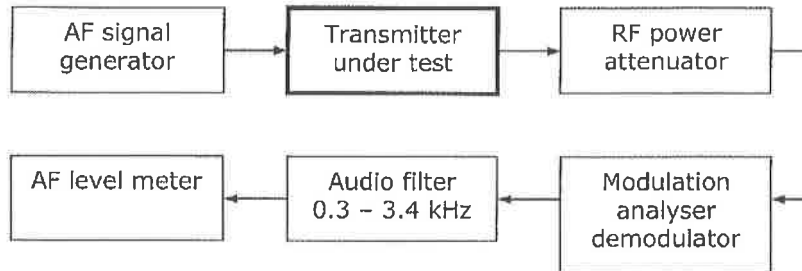

- 2.3.11.1 Apply electrically a 1 kHz audio test signal to the microphone input of the transmitter at a level sufficient to produce the standard test modulation factor.
- 2.3.11.2 Record the audio output level from the modulation analyser demodulator.
- 2.3.11.3 Remove the modulation from the transmitter.
- 2.3.11.4 Again record the audio output level from the modulation analyser demodulator.
- 2.3.11.5 Calculate the angle modulation hum and noise ratio by determining the difference between the two measurements in dB.

Note: Care must be taken not to generate hum when the audio signal is connected electrically.
Short circuit the audio input connections of the radio transmitter when the audio signal is removed.

2.3.12 Amplitude modulation hum and noise level

Connect the equipment as shown below.

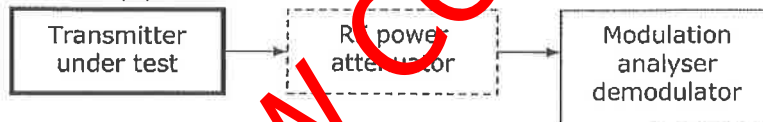

- 2.3.12.1 Set the modulation analyser to measure the RMS AM modulation factor (m %).
- 2.3.12.2 In the absence of an audio input signal (modulating signal) measure the modulation factor.
- 2.3.12.3 Calculate the AM hum and noise level as follow:
AM hum and noise level (dB) = 20Log(2 m/100)

2.3.13 Extreme transmitter loads

Connect the equipment as shown below.

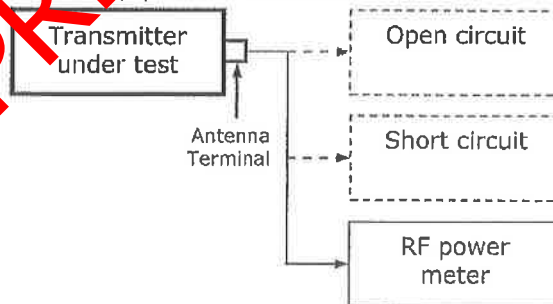

- 2.3.13.1 Measure the carrier power in the absence of modulation.
- 2.3.13.2 Operate the transmitter under open and short circuit load conditions for a period of:
 - 2.3.13.2.1 One minute each in the case of a transmitter rated for intermittent duty cycle.
 - 2.3.13.2.2 Five minutes each in the case of a transmitter rated for continuous operation.

-
- 2.3.13.3 After each exposure to the extreme load measure the carrier power in the absence of modulation.
- 2.3.13.4 Calculate the variation of the carrier power in dB with reference to clause 2.3.13.1.

"PREVIEW COPY ONLY"

2.4 High Site Equipment

2.4.1 Radio Base Station Response Time

Connect the equipment as shown below.

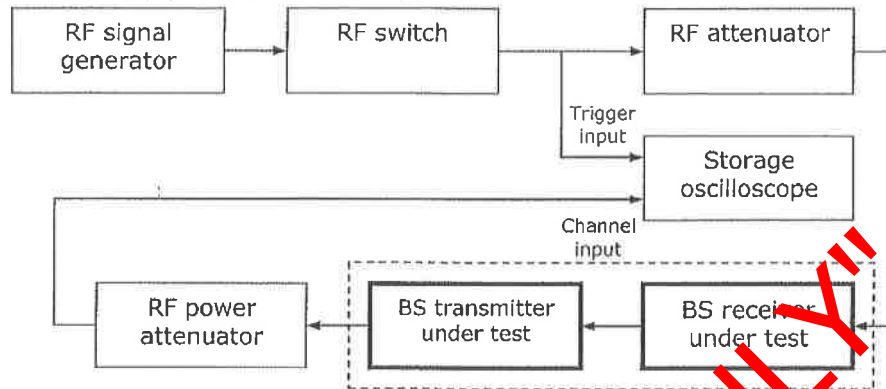

- 2.4.1.1 Apply a standard RF test signal to the receiver under test.
- 2.4.1.2 Determine the usable sensitivity as described in clause 2.2.3.
- 2.4.1.3 Adjust the squelch to open at a RF signal level of -117 dBm, measured at the antenna terminal.
- 2.4.1.4 Set the RF signal level 12 dB above the usable sensitivity level.
- 2.4.1.5 Set the storage oscilloscope to single sweep operation.
- 2.4.1.6 Enable the RF switch and measure the time required for the unmodulated transmit carrier voltage level to reach a value 6 dB (50%) below the steady state level.
- 2.4.1.7 Repeat the measurement three times and take the average of the three measurements as the repeater attack time.

2.4.2 Talk Through Signal2.4.2.1 Audio levels

Connect the equipment as shown below.

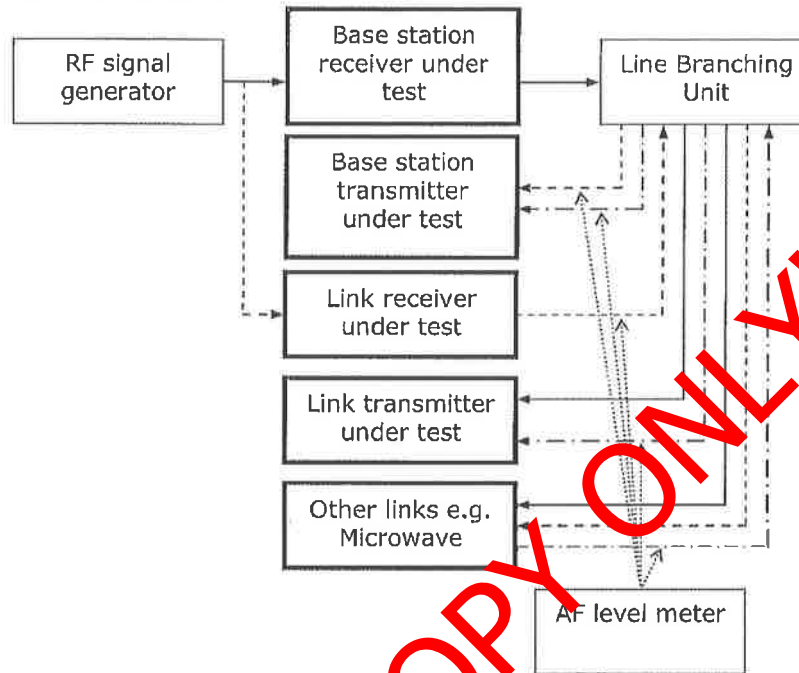

- 2.4.2.1.1 Adjust the RF signal generator to produce the standard RF test signal.
- 2.4.2.1.2 Connect the audio lines to the units as it would be connected when in operation. This is to ensure that the lines are correctly loaded.
- 2.4.2.1.3 Set the audio frequency level meter to high impedance/bridge mode. This is to ensure that the level meter does not load the lines.
- 2.4.2.1.4 Measure the audio level from the source (Rx) first. Adjust the level if necessary.
- 2.4.2.1.5 Measure all the outgoing lines from the LBU and adjust the levels if necessary.
- 2.4.2.1.6 Use the method described in clauses 2.4.2.1.1 to 2.4.2.1.4 to measure and adjust the audio level from the link receiver.
- 2.4.2.1.7 Measure the audio level from the microwave and adjust if necessary.

Note: The same measuring method is used on the Trunked radio equipment.

2.4.2.2 **Audio Frequency Response**

Connect the equipment as shown below.

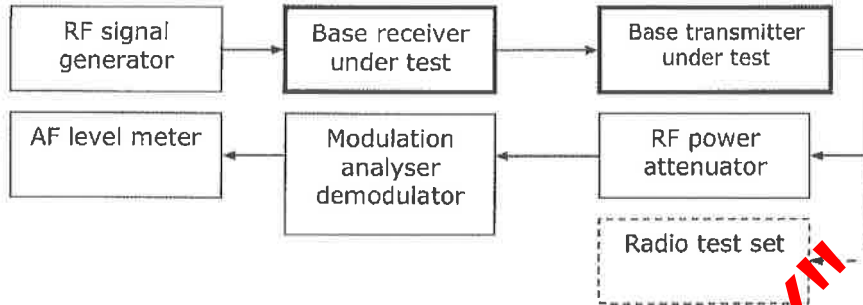

- 2.4.2.2.1 Ensure that all the audio level settings have been set correctly.
- 2.4.2.2.2 Adjust the RF signal generator to produce the standard RF test signal.
- 2.4.2.2.3 Select the low pass filter (cut-off 20 kHz) at the modulation analyser.
- 2.4.2.2.4 While keeping the modulation factor constant vary the modulating frequency over the range 300 Hz to 3 kHz.
- 2.4.2.2.5 Record the variation in the audio output power from the demodulator over this range in dB with reference to the corresponding level at 1 kHz.
- 2.4.2.2.6 Branches to the link radio and other links must also be measured.

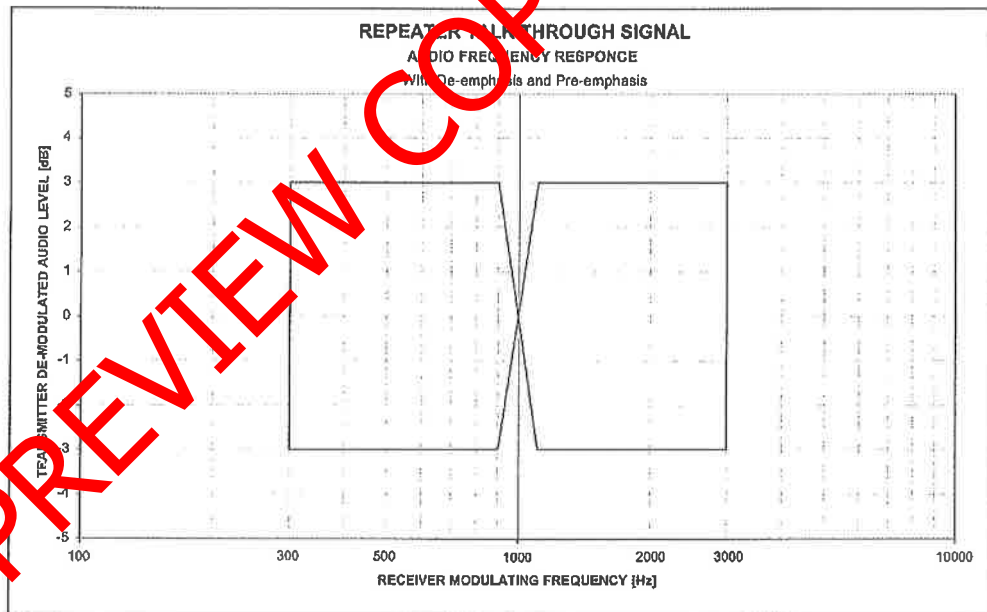

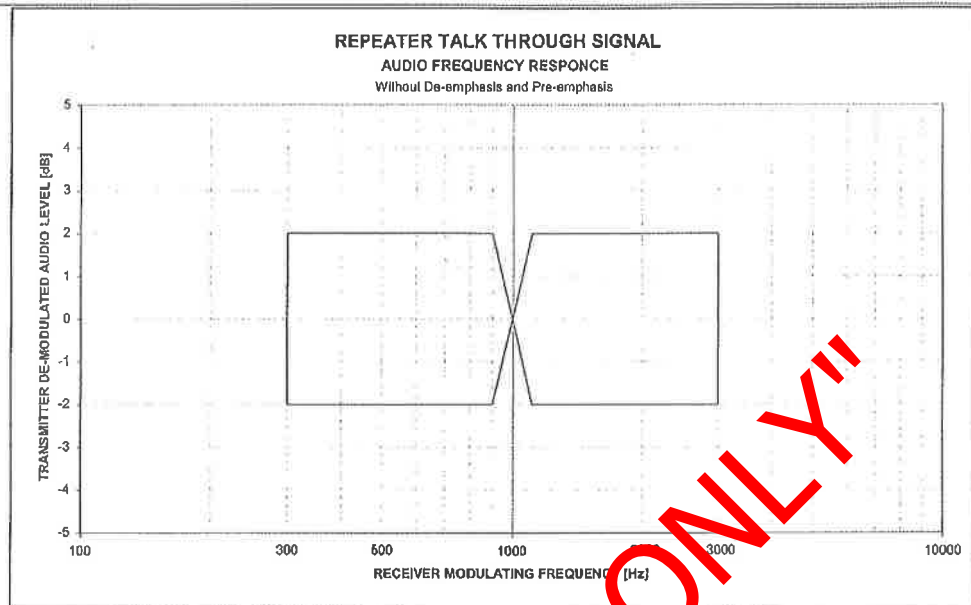

2.4.2.3 Modulation factor linearity

Connect the equipment as shown below.

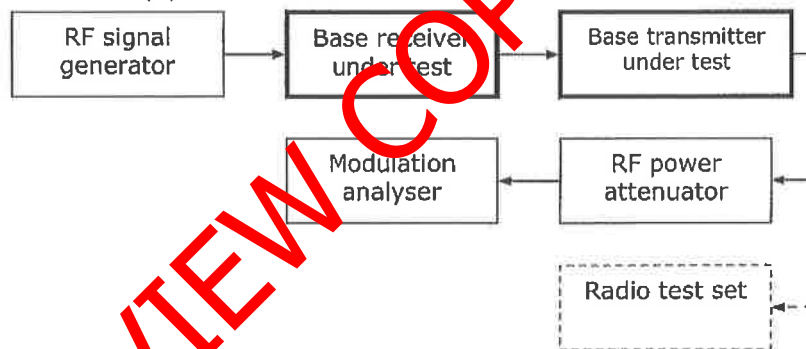

2.4.2.3.1 Ensure that the transmitter modulation limiting (deviation) has been set correctly (see clause 2.3.7).

2.4.2.3.2 Ensure that all the audio levels have been set correctly (see clause 2.4.2.1).

2.4.2.3.3 Apply a standard RF test signal from the RF signal generator to the receiver.

2.4.2.3.4 Vary the modulation of the RF input signal between 0.5 kHz and 2.5 kHz and measure the transmitter deviation.

2.4.2.3.5 Branches to the link radio and other links must also be measured.

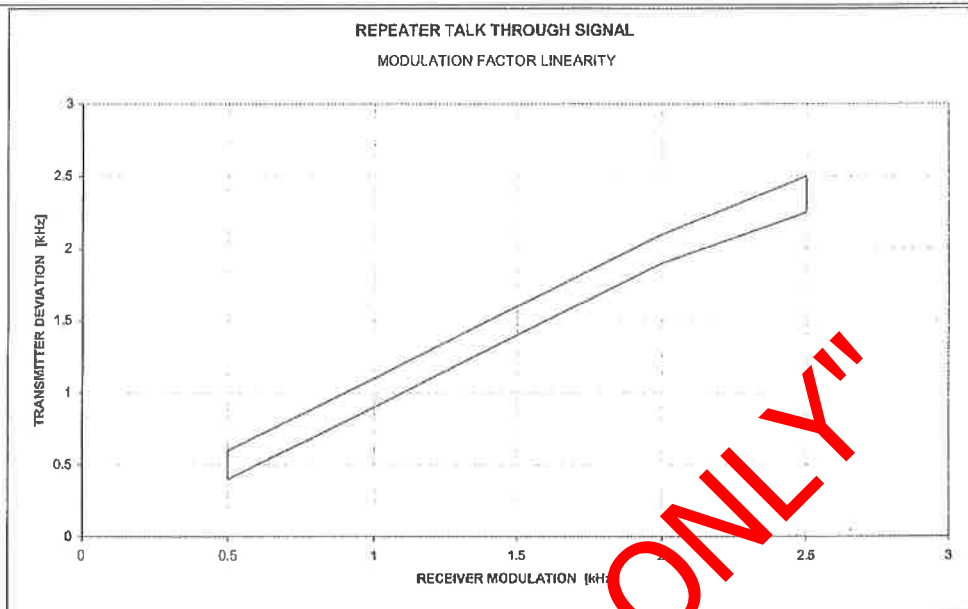

2.4.2.4 **Audio frequency THD**

Connect the equipment as shown below.

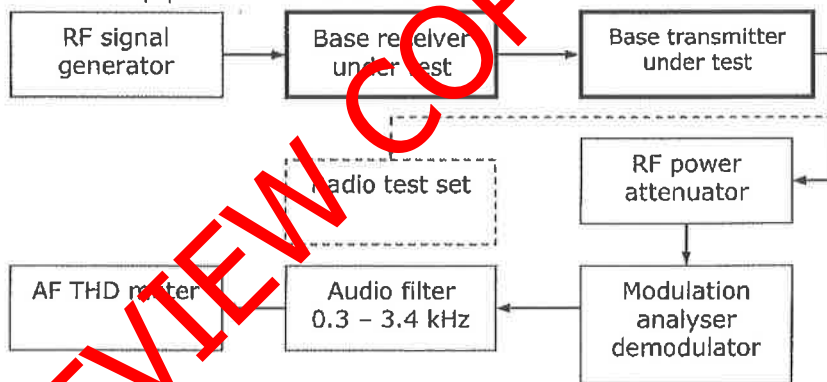

2.4.2.4.1 Ensure that all the audio levels are set correctly.

2.4.2.4.2 Apply a standard RF test signal to the receiver under test.

2.4.2.4.3 Record the audio total harmonic distortion from the transmitter.

2.4.2.4.4 Branches to the link radio and other links must also be measured.

2.4.3 Filters

2.4.3.1 Duplexer

The best method to check or tune a duplexer is to use a Transmission Line Analyser. This measuring method will not be covered in this document.

If any problem is detected the duplexer/combiner must be sent to a facility with the proper equipment and competency. Do not attempt to tune the unit.

A RF signal generator and a test receiver/spectrum analyser could be used to make measurements.

2.4.3.1.1 Calibration

2.4.3.1.1.1 Connect the RF signal generator with the two connecting cables to the test receiver or spectrum analyser.

2.4.3.1.1.2 Tune the RF signal generator and the test receiver/spectrum analyser to the in-band receiving/transmitting frequency to be measured.

2.4.3.1.1.3 Set the output level of the RF signal generator as required:

e.g. Low-level : ≤ -60 dBm

High-level : 0 dBm.

2.4.3.1.1.4 Record the difference between the applied and measured signal level. The difference must be included in the calculation.

Note: This method compensates for differences and the connecting cable losses.

2.4.3.1.2 Insertion loss - Rx

Connect the equipment as shown below.

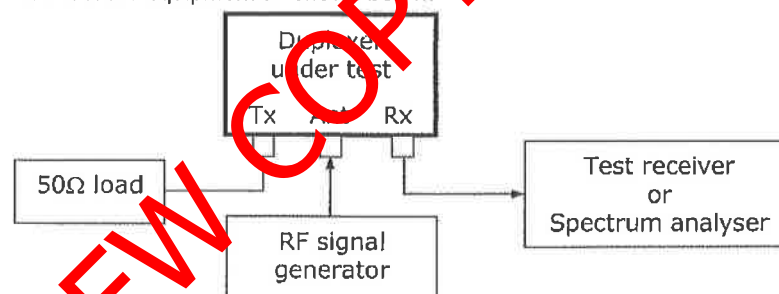

2.4.3.1.2.1 Tune the RF signal generator and the test receiver/spectrum analyser to the in-band receiving frequency to be measured.

2.4.3.1.2.2 Inject the signal at the antenna port (low level) and measure the level at the receiving port.

2.4.3.1.2.3 Calculate the insertion loss by determining the difference between the injected signal level and the measured level in dB.

2.4.3.1.2.4 The insertion loss must comply throughout the operating band.

At the high site this measurement can be made in the following way:

2.4.3.1.2.5 Connect the RF signal generator directly to the receiver.

2.4.3.1.2.6 Adjust the RF signal generator to produce a standard RF test signal.

2.4.3.1.2.7 Decrease the RF signal level till the squelch closes.

2.4.3.1.2.8 Increase the RF signal level **slowly** and note the level when the squelch open.

2.4.3.1.2.9 Connect the RF signal generator to the receiver via the duplexer (Ant port).

2.4.3.1.2.10 Repeat the procedure from clause 2.4.3.1.2.6 to 2.4.3.1.2.8.

2.4.3.1.2.11 Calculate the insertion loss by determining the difference between the two recorded signal levels in dB.

Note: When the result is within specification, the insertion loss through the coaxial cable between the receiver and duplexer can be ignored.

2.4.3.1.3 Insertion loss - Tx

Connect the equipment as shown below.

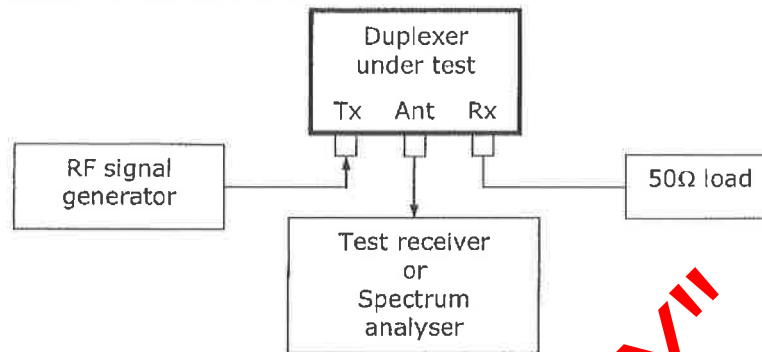

- 2.4.3.1.3.1 Tune the RF signal generator and the test receiver/spectrum analyser to the in-band transmitting frequency to be measured.
- 2.4.3.1.3.2 Inject the signal at the transmitting port (high level), and measure the level at the antenna port.
- 2.4.3.1.3.3 Calculate the insertion loss by determining the difference between the injected signal level and the measured level in dB.
- 2.4.3.1.3.4 The insertion loss must comply throughout the operating band.
- At the high site this measurement can be made in the following way:
- 2.4.3.1.3.5 Connect a terminated wattmeter directly to the transmitter.
- 2.4.3.1.3.6 Measure the un-modulated carrier power from the transmitter.
- 2.4.3.1.3.7 Connect the same terminated wattmeter to the transmitter via the duplexer (Antenna port).
- 2.4.3.1.3.8 Measure the un-modulated carrier power from the transmitter.
- 2.4.3.1.3.9 Calculate the insertion loss by determining the difference between the two measured power levels in dB.

Note: When the result is within specification, the insertion loss through the coaxial cable between the transmitter and duplexer can be ignored.

2.4.3.1.4 Isolation between the transmitting and receiving paths

Connect the equipment as shown below.

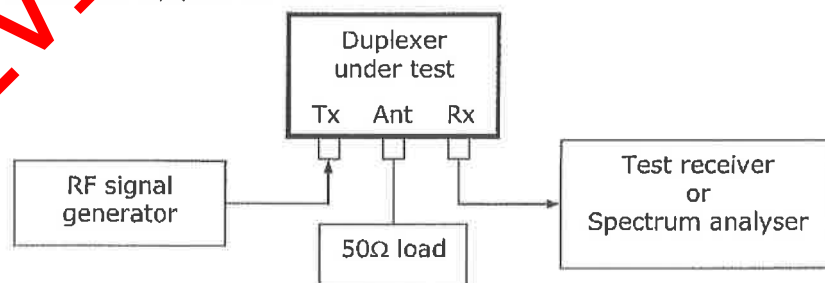

- 2.4.3.1.4.1 Tune the RF signal generator and the test receiver/spectrum analyser to the in-band transmitting frequency to be measured.
- 2.4.3.1.4.2 Inject the signal at the transmitting port (high level) and measure the level at the receiving port.
- 2.4.3.1.4.3 Calculate the isolation by determining the difference between the injected signal level and the measured level in dB.
- 2.4.3.1.4.4 The isolation must comply throughout the operating band.

2.4.3.1.5 Impedance matching

Connect the equipment as shown below.

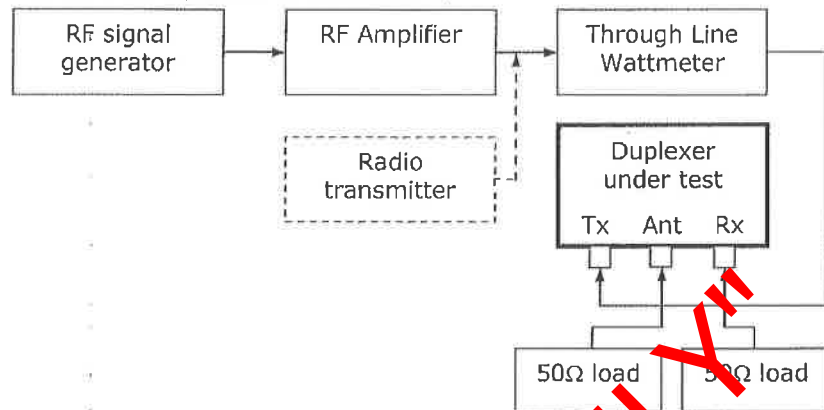

- 2.4.3.1.5.1 Tune the RF signal generator to the in-band transmitting frequency to be measured.
- 2.4.3.1.5.2 Measure the Voltage Standing Wave Ratio (VSWR) with a through line wattmeter.
- 2.4.3.1.5.3 If the wattmeter does not indicate the VSWR, note the forward and reflected power and calculate the VSWR.
- $$\left(1 + \sqrt{\text{Power reflected/Power forward}}\right) / \left(1 - \sqrt{\text{Power reflected/Power forward}}\right)$$
- 2.4.3.1.5.4 The impedance matching must comply throughout the operating band.
- 2.4.3.1.5.5 Use the same method to measure the impedance at the receiver and antenna terminals.

2.4.3.2 Combiner

2.4.3.2.1 Insertion loss - Tx

- 2.4.3.2.1.1 The insertion loss can be measured as explained in clause 2.4.3.1.2.
- 2.4.3.2.1.2 Fifty-ohm loads must be connected to all open transmitting and receiving ports.
- 2.4.3.2.1.3 The reflected signal level at the antenna port must be low (≤ -80 dBm) to prevent the RF amplifier in the receiving path being saturated.
- 2.4.3.2.1.4 All the receiving ports must be measured.
- 2.4.3.2.1.5 The insertion loss must comply throughout the operating band.

2.4.3.2.2 Insertion loss - Rx

- 2.4.3.2.2.1 The insertion loss can be measured as explained in clause 2.4.3.1.3.
- 2.4.3.2.2.2 Fifty-ohm loads must be connected to all open transmitting and receiving ports.
- 2.4.3.2.2.3 All the transmitting ports must be measured.
- 2.4.3.2.2.4 The insertion loss must comply throughout the operating band.

2.4.3.2.3 Isolation between the transmitting and receiving paths

- 2.4.3.2.3.1 The isolation between the transmitting and receiving paths can be measured as explained in clause 2.4.3.1.4.
- 2.4.3.2.3.2 Fifty-ohm loads must be connected to all open transmitting and receiving ports.
- 2.4.3.2.3.3 All the ports must be measured.
- 2.4.3.2.3.4 The isolation must comply throughout the operating band.

2.4.3.2.4 **Isolation between the transmitting ports**

Connect the equipment as shown below

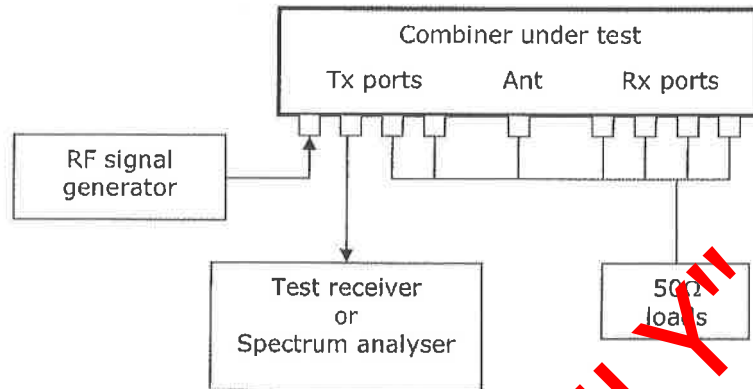

- 2.4.3.2.4.1 Tune the RF signal generator and the test receiver/spectrum analyser to the in-band transmitting frequency to be measured.
- 2.4.3.2.4.2 Fifty-ohm loads must be connected to the antenna and all open transmitting and receiving ports.
- 2.4.3.2.4.3 Inject the signal at the first transmitting port (high level) and measure the level at the other transmitting ports.
- 2.4.3.2.4.4 Repeat step 2.4.3.2.4.3 when injecting the signal at ports 2 to 4.
- 2.4.3.2.4.5 Calculate the isolation by determining the difference between the injected signal level and the measured level in dB.
- 2.4.3.2.4.6 The isolation must comply throughout the operating band.

2.4.3.2.5 **Impedance matching**

- 2.4.3.2.5.1 The impedance matching can be determined as explained in clause 2.4.3.1.5.
- 2.4.3.2.5.2 Fifty-ohm loads must be connected to all open transmitting and receiving ports.
- 2.4.3.2.5.3 All the transmitting ports must be measured.

Note: Do not use this method to determine the impedance matching at the receiver and antenna terminals. If a problem is suspected, the combiner must be sent to a facility with the proper equipment and competency.

2.4.4 **Coaxial Cable**

2.4.4.1 **Impedance matching**

The best method to measure the impedance and insertion loss of the coaxial cable is to use a Transmission Line Analyser. This measuring method will not be covered in this document.

Connect the equipment as shown below.

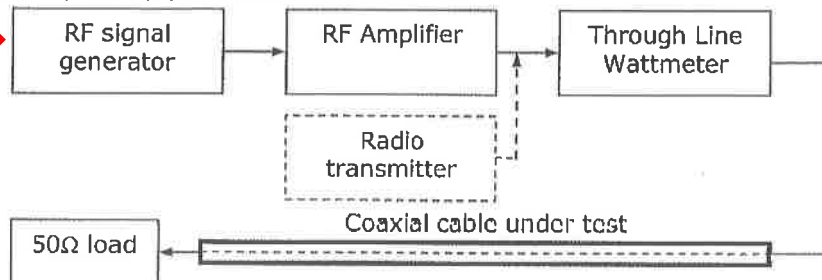

- 2.4.4.1.1 Tune the RF signal generator to the in-band transmitting frequency.
- 2.4.4.1.2 Measure the Voltage Standing Wave Ratio (VSWR) with a through line wattmeter.
- 2.4.4.1.3 If the wattmeter does not indicate the VSWR, note the forward and reflected power and calculate the VSWR (see clause 2.4.3.1.5.3).

- 2.4.4.1.4 Tune the RF signal generator to the in-band receiving frequency.
- 2.4.4.1.5 Measure the Voltage Standing Wave Ratio as above.
- 2.4.4.1.6 The impedance matching must comply throughout the operating band.
- 2.4.4.1.7 Record the worst case as the impedance matching.

2.4.4.2 Insertion loss

Connect the equipment as shown below.

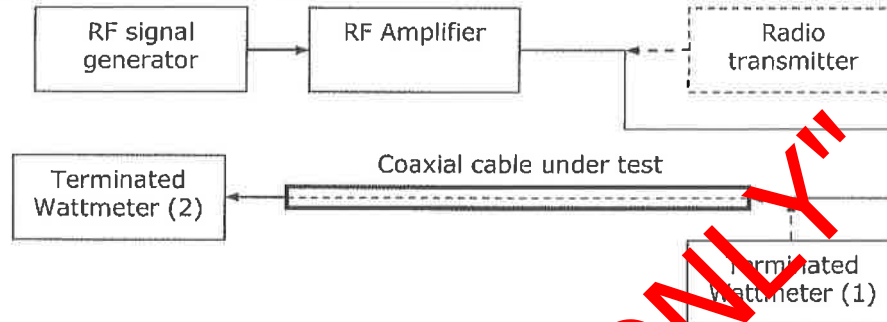

- 2.4.4.2.1 Tune the RF signal generator to the in-band transmitting frequency.
- 2.4.4.2.2 Measure the power at the near end of the coaxial cable using the terminated wattmeter (1).
- 2.4.4.2.3 Measure the power at the far end of the coaxial cable using the same terminated wattmeter (2).
- 2.4.4.2.4 Calculate the insertion loss by determining the difference between the power levels measured in dB.
- 2.4.4.2.5 Tune the RF signal generator to the in-band receiving frequency.
- 2.4.4.2.6 Repeat the measurements as above.
- 2.4.4.2.7 The insertion loss must comply throughout the operating band.
- 2.4.4.2.8 Record the highest loss measured, as the insertion loss.

2.4.5 Antenna

2.4.5.1 Impedance matching

The best method to measure the impedance of the antenna is to use a Transmission Line Analyser. This measuring method will not be covered in this document.

Connect the equipment as shown below.

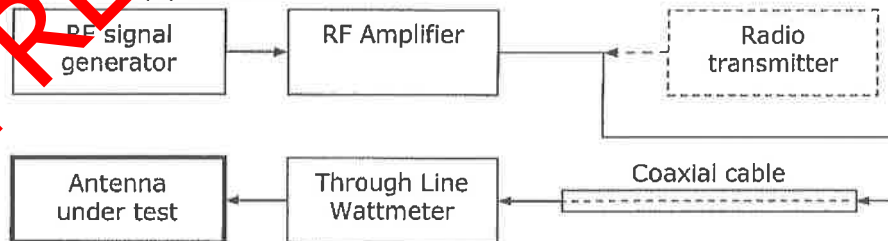

- 2.4.5.1.1 The impedance matching of the coaxial cable (clause 2.4.4.1) must be measured first.
- 2.4.5.1.2 Tune the RF signal generator to the in-band transmitting frequency.
- 2.4.5.1.3 Measure the Voltage Standing Wave Ratio (VSWR) with a through line wattmeter.
- 2.4.5.1.4 If the wattmeter does not indicate the VSWR, note the forward and reflected power and calculate the VSWR (see clause 2.4.3.1.5.3).
- 2.4.5.1.5 Tune the RF signal generator to the in-band receiving frequency.
- 2.4.5.1.6 Measure the Voltage Standing Wave Ratio as above.

- 2.4.5.1.7 The impedance matching must comply throughout the operating band.
 2.4.5.1.8 Record the worst case as the impedance matching.

2.4.5.2 **Effective Radiated Power (ERP)**

- 2.4.5.2.1 The effective radiated power is calculated as follows:
 The RF power measured into a $50\ \Omega$ load that replaces the antenna, times the gain of the antenna with reference to a Dipole antenna (dBd).
 2.4.5.2.2 The following calculation could also be used:
 Antenna gain (dBd) - Duplexer/combiner insertion loss (dB) - Coaxial cable insertion loss (dB) + Transmitting power at transmitter (dBm). Convert the result to Watts ($0.001 \times \text{Antilog}(\text{dB}/10)$).

2.4.6 **Receiver Desensitisation (Desensing)**

Connect the equipment as shown below.

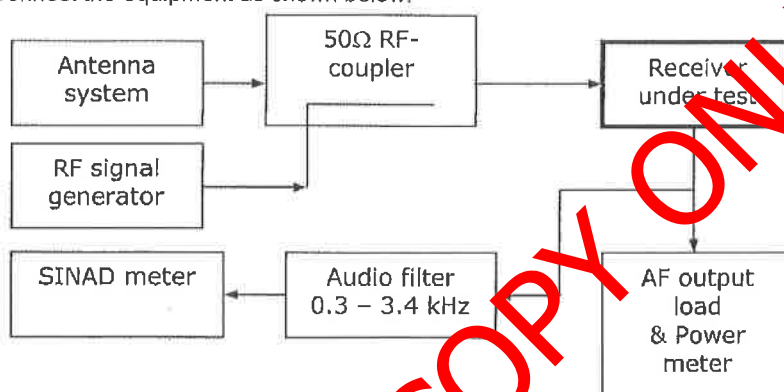

- 2.4.6.1 The transmitting power of all the transmitters must be set correctly.
 2.4.6.2 The insertion loss of the RF coupler must be ≤ 1 dB.
 2.4.6.3 Adjust the RF signal generator to produce the standard test signal and apply it to the receiver via the RF-coupler.
 2.4.6.4 Reduce the RF signal output level until the SINAD ratio is 12 dB.
 2.4.6.5 Note the RF signal level at which the 12 dB SINAD is obtained.
 2.4.6.6 Transmit from the other transmitters situated on the site.
 2.4.6.7 Note if the SINAD ratio is degrading.
 2.4.6.8 If so, while transmitting increase the RF signal output from the generator to obtain a SINAD ratio of 12 dB.
 2.4.6.9 Note the RF signal level.
 2.4.6.10 Calculate the desensing level by determining the difference between the two measurements in dB.

2.4.7 **Audio Line Branching Unit (LBU)**

2.4.7.1 **Impedance matching**

Connect the equipment as shown below.



- 2.4.7.1.1 Switch the power of the LBU on.
 2.4.7.1.2 Measure the return loss of the input transformer to determine the impedance matching.

- 2.4.7.1.3 Repeat the measurement to determine the impedance matching of the other input and output terminals.

2.4.7.2 Audio levels

Connect the equipment as shown below.

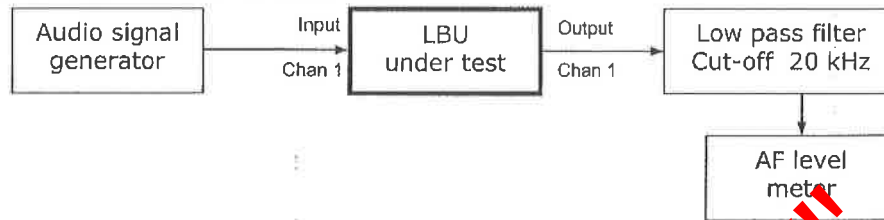

- 2.4.7.2.1 Ensure that the audio signal generator and audio level meter are set to the correct impedance.
- 2.4.7.2.2 Route all the input terminals to all the output terminals. This is required for the tests that follow.
- 2.4.7.2.3 Apply a 1 kHz signal at a level of -10 dBm into channel 1 of the LBU.
- 2.4.7.2.4 Measure the signal level at the output terminals of the LBU.
- 2.4.7.2.5 Adjust the output levels to obtain -10 dBm if necessary.
- 2.4.7.2.6 Repeat the measurements with the audio signal applied to the other input terminals.
- 2.4.7.2.7 All output levels should be -10 dBm without readjustment.

2.4.7.3 Audio frequency response

Connect the equipment as shown below.

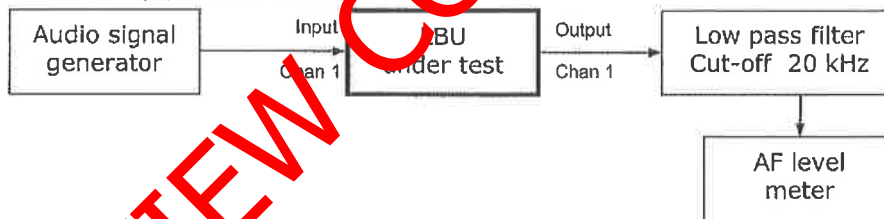

- 2.4.7.3.1 Ensure that all the audio levels are set correctly.
- 2.4.7.3.2 Apply a 1 kHz signal at a level of -10 dBm into channel 1 of the LBU.
- 2.4.7.3.3 Measure the signal level at the output terminal of channel 1.
- 2.4.7.3.4 While keeping the audio signal level constant vary the frequency from 300 Hz to 3 kHz.
- 2.4.7.3.5 Record the variation of the audio output level in dB with reference to the corresponding level at 1 kHz.
- 2.4.7.3.6 Repeat the measurements with the audio signal applied to the other input terminals.

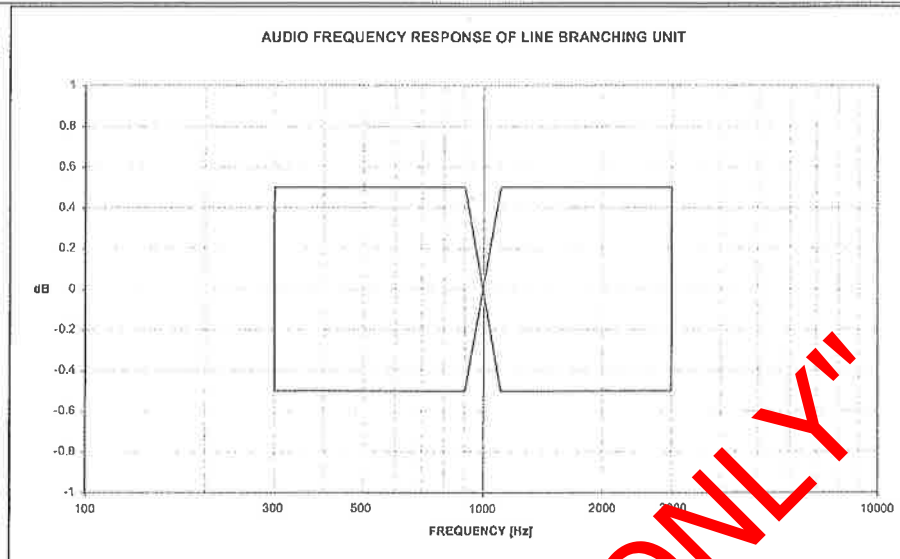

2.4.7.4 Audio total harmonic distortion (THD)

Connect the equipment as shown below.

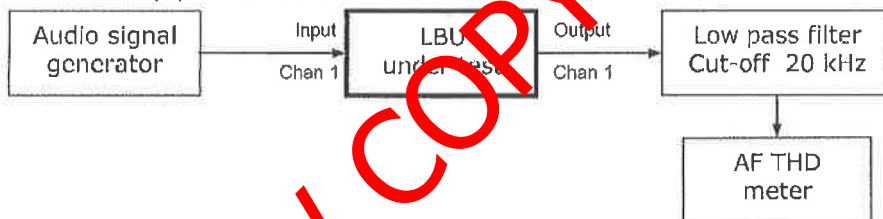

2.4.7.4.1 Ensure that all the audio levels are set correctly.

2.4.7.4.2 Route all the input terminals to all the output terminals.

2.4.7.4.3 Ensure that the audio signal generator and THD meter are set to the correct impedance.

2.4.7.4.4 Apply a 1 kHz signal at a level of -10 dBm into channel 1 of the LBU.

2.4.7.4.5 Record the audio total harmonic distortion obtained at the output terminals.

2.4.7.4.6 Repeat the measurements with the audio signal applied to the other input terminals.

2.4.7.5 Audio signal to hum and noise ratio

Connect the equipment as shown below.

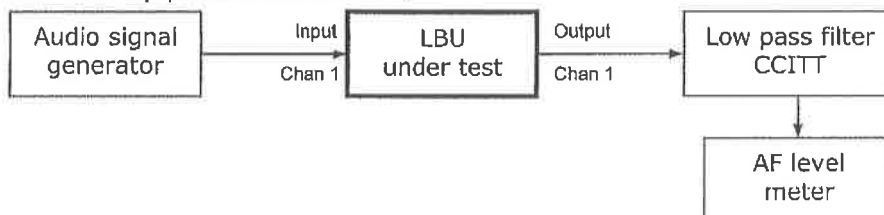

2.4.7.5.1 Ensure that all the audio levels are set correctly.

2.4.7.5.2 Route all the input terminals to all the output terminals.

2.4.7.5.3 Apply a 1 kHz signal at a level of -10 dBm into channel 1 of the LBU.

- 2.4.7.5.4 Short-circuit all the other input terminals.
- 2.4.7.5.5 Measure the signal level at the output terminals of the LBU.
- 2.4.7.5.6 Remove the audio signal generator and short circuit the input terminal (1) of the LBU.
- 2.4.7.5.7 Measure the signal level at the output terminals of the LBU.
- 2.4.7.5.8 Calculate the ratio in dB between the audio output levels obtained with and without the applied audio signal, as the signal to hum and noise ratio.
- 2.4.7.5.9 Repeat the measurements with the audio signal applied to the other input terminals.
- 2.4.7.5.10 Record the lowest ratio as the result.

2.4.7.6 Channel cross talk

Connect the equipment as shown below.

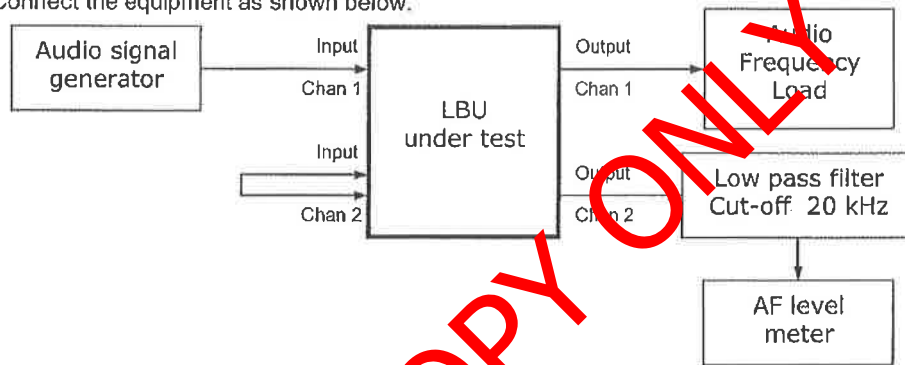

- 2.4.7.6.1 Route all the channels to operate separately e.g. Channel 1 input terminal to channel 1 output terminal; channel 2 input terminal to channel 2 output terminal; etc.
- 2.4.7.6.2 Ensure that all the level settings are correct for each channel.
- 2.4.7.6.3 Inject a 1 kHz signal at a level of -10 dBm into channel 1 of the LBU.
- 2.4.7.6.4 Short-circuit all the other input terminals.
- 2.4.7.6.5 Calculate the ratio in dB between the audio input signal level and that measured at the other output terminals, except that of channel 1.
- 2.4.7.6.6 Repeat the measurements with the audio signal injected into the other input terminals.
- 2.4.7.6.7 Record the worst case as the result.

2.4.7.7 Common-mode rejection ratio

Connect the equipment as shown below.

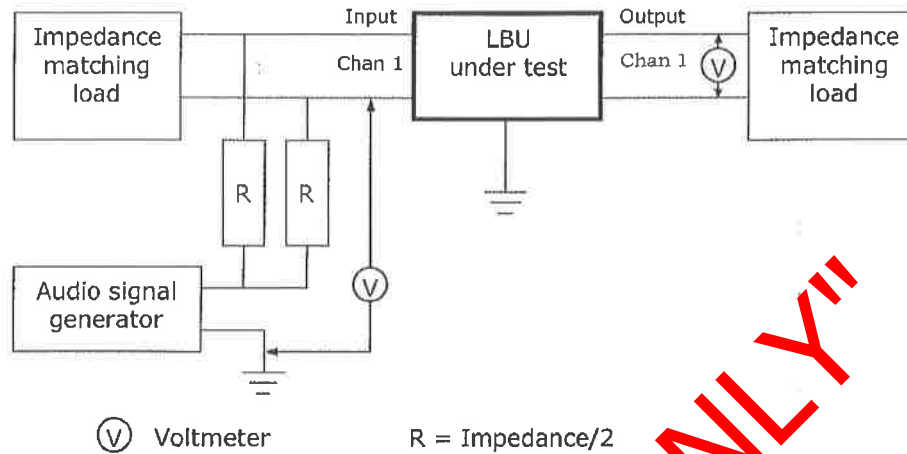

- 2.4.7.7.1 Adjust the amplification of the LBU to unity gain. If the gain cannot be adjusted, measure the input and output voltage levels and calculate the gain.
- 2.4.7.7.2 Set the audio signal generator frequency to 1 kHz and set the output impedance to HIGH.
- 2.4.7.7.3 Increase the signal output level of the audio generator till the level measured on the output line of the LBU also increases.
- 2.4.7.7.4 Record the input and output signal voltage levels.
- 2.4.7.7.5 If the LBU is set for unity gain, calculate the ratio in dB between the audio input signal level and that measured on the output line of the LBU.
OR
- 2.4.7.7.6 If the LBU has a gain, calculate the ratio by dividing the input voltage level by the output voltage level.
Multiply the calculated ratio with the gain of the LBU under tests and express the ratio in dB.
e.g. Input voltage/Output voltage = R:1
 $R \times \text{Gain} = T:1$
 $\text{dB} = 20\text{Log}_{10}(T/1)$
- 2.4.7.7.7 Repeat the measurement on the other channels.
- 2.4.7.7.8 Record the worst case as the result.

2.4.7.8 **E & M-signalling**

Connect the equipment as shown below.

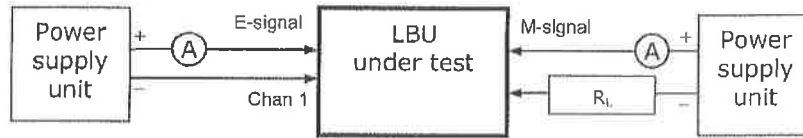

(A) Ammeter

- 2.4.7.8.1 Route the E-signal of channel 1 to activate the M-signal of all the channels.
- 2.4.7.8.2 The value of the load resistor R_L must be such to permit a current flow of 8 mA to 10 mA.
- 2.4.7.8.3 Apply a DC voltage at the appropriate level to the M-signal terminal.
- 2.4.7.8.4 Apply a DC voltage at the appropriate level to the E-signal terminal and measure the current.
- 2.4.7.8.5 Measure the current flow at all the M-signal terminals.
- 2.4.7.8.6 Reverse the voltage polarity at the E & M-signal terminals and repeat the test.
- 2.4.7.8.7 Repeat the above tests with other routing combinations.
- 2.4.7.8.8 Measure the resistance between the E & M-signal terminals and the LBU earth. The resistance must be infinity.

2.4.8 **Power Supply & Battery Charger Unit**2.4.8.1 **Output voltage regulation**

Connect the equipment as shown below.

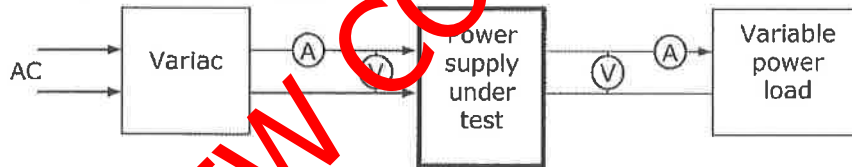

(V) Voltmeter

(A) Ammeter

- 2.4.8.1.1 Intermittent:
 - 2.4.8.1.1.1 Adjust the Variac to obtain the nominal input voltage to the power supply/battery charger.
 - 2.4.8.1.1.2 Vary the power load to obtain a current drain from 0 ampere to maximum current while recording the output voltage.
 - 2.4.8.1.1.3 The measurement shall be made under the extreme test conditions as well.
- 2.4.8.1.2 Continuous:
 - 2.4.8.1.2.1 Adjust the Variac to obtain the nominal input voltage to the power supply/battery charger.
 - 2.4.8.1.2.2 Set the power load to obtain the maximum current drain and record the output voltage level for a period of four hours.

2.4.8.2 **Efficiency**

Connect the equipment as shown below.

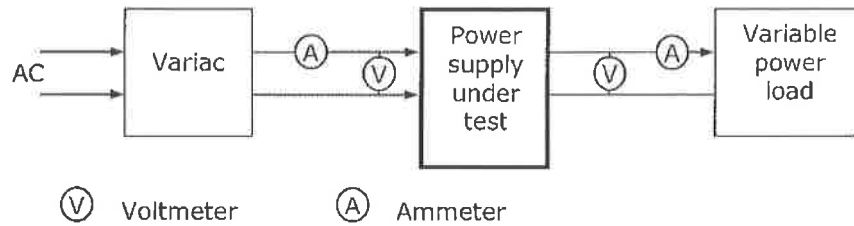

- 2.4.8.2.1 Adjust the Variac to obtain the nominal input voltage to the power supply/battery charger.
- 2.4.8.2.2 Vary the power load to obtain a current drain from 0 ampere to maximum current while recording the input and output voltages and currents.
- 2.4.8.2.3 Calculate the efficiency in percentage.

$$\text{Efficiency} = (\text{Power out}/\text{Power in}) \times 100 \%$$
- 2.4.8.2.4 Repeat the test with the specified minimum and then the maximum input voltage to the power supply/battery charger.
- 2.4.8.2.5 Record the worst case as the result.

2.4.8.3 **Output voltage ripple**

Connect the equipment as shown below.

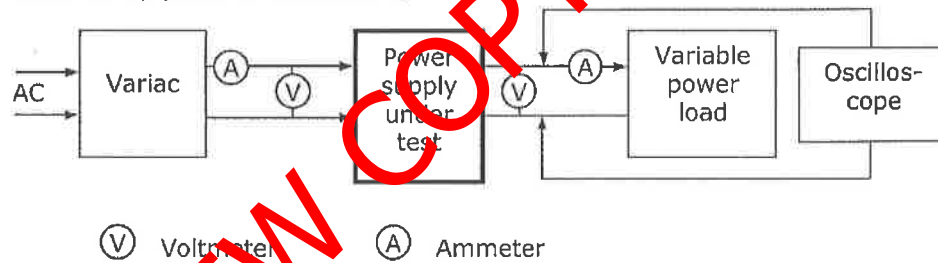

- 2.4.8.3.1 Adjust the Variac to obtain the nominal input voltage to the power supply/battery charger.
- 2.4.8.3.2 Vary the power load to obtain a current drain from 0 ampere to maximum current while recording the output voltage ripple with the oscilloscope.
- 2.4.8.3.3 The measurement shall be made under the extreme test conditions as well.
- 2.4.8.3.4 Record the worst case as the result.

Note: Some battery chargers apply high instantaneous pulses of short duration. In a Lead-acid battery, this breaks down lead-sulphate crystals, thus extending the battery service life. This function must be noted.

2.4.8.4 **Radiation of spurious frequencies**

Connect the equipment as shown below.

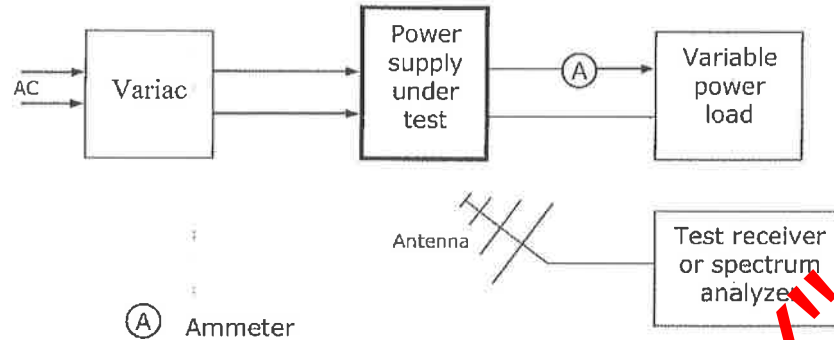

- 2.4.8.4.1 This test has to be performed inside a Faraday cage (RF shielding).
- 2.4.8.4.2 All the instruments and electrical equipment inside the cage not used for the test have to be switched off to prevent interference with the frequencies to be scanned. Ideally, all the equipment except the power supply under test and the antenna should be on the outside of the cage.
- 2.4.8.4.3 The measuring antenna to be placed 1 m from the power supply/battery charger.
- 2.4.8.4.4 Vary the power load to obtain a current drain from 0 ampere to maximum current while scanning the radio-operating band (455.0000 MHz to 467.0000 MHz).
- 2.4.8.4.5 Record the frequencies and levels of all the detected signals.

2.4.8.5 **Desensing of receiver (conductive)**

Connect the equipment as shown below.

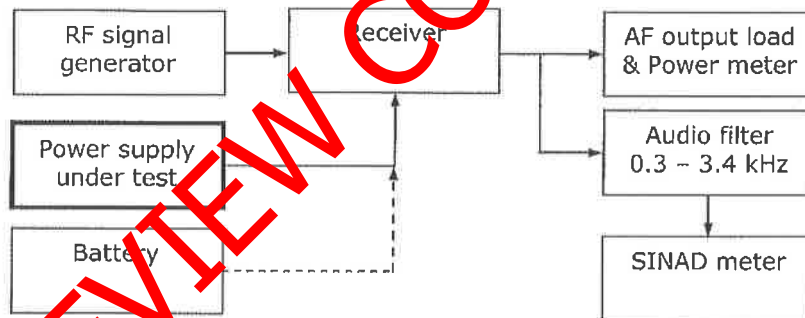

- 2.4.8.5.1 Use a battery to power the receiver.
- 2.4.8.5.2 Adjust the RF signal generator to produce a standard RF test signal.
- 2.4.8.5.3 Adjust the volume control of the radio to give SOP.
- 2.4.8.5.4 Reduce and record the RF signal input level at which 12 dB SINAD ratio is obtained.
- 2.4.8.5.5 Replace the battery with the power supply under test.
- 2.4.8.5.6 The length of the power leads to the radio must be 1.0 m.
- 2.4.8.5.7 Place the power supply as far as possible from the radio.
- 2.4.8.5.8 Roadjust and record the RF signal output level at which 12 dB SINAD ratio is obtained.
- 2.4.8.5.9 Record the difference in dB between the recorded RF signal levels as the receiver desensing.

2.5 Trunking functional tests

Programme the radio under test with the correct trunking parameters and with a validated number on the trunk network.

1.5.1 On instrument

Connect the radio under test to the trunk enabled instrument.

1.5.1.1 Registration

Switch the radio on and ensure that it register on the instrument. The radio will display a registered indication and the instrument will display the radio's trunking number.

1.5.1.2 Make a call with the same prefix number (e.g. 2052001203 to 2052001204).

The instrument will display the called radio's prefix and the *derived* identification number.

1.5.1.3 Make a call with the interprefix number (e.g. interfleet call: 2052001203 to 2142001301).

The instrument will display the called radio's prefix and the *derived* identification number.

1.5.1.4 Short form dialling (e.g. 204)

Repeat 1.5.1.2 using the short form dialling.

1.5.1.5 PSTN call (e.g. 0117748227)

The dialled number must be presided with 0 (e.g. 00117748227). The instrument will display the called number.

1.5.1.6 Call the radio under test

Make a call to the radio from the instrument.

1.5.1.7 Handoff

Change the control channel on the instrument and ensure that the radio re-register on the new channel.

1.5.2 On trunk system

Two trunk radios and a PSTN telephone must be available and dedicated to the tests.

One trunk radio must be programmed with the same prefix number as the radio under test and the second radio with an interprefix number.

1.5.2.1 Registration

Switch the radio under test on and ensure that it register on the trunk system. The radio will display a registered indication.

1.5.2.2 Local call

Ensure that all the trunk radios are registered on the same local site.

1.5.2.2.1 Call a radio with the same prefix number

Call the radio having the same prefix number. Have a conversation with the second party.

1.5.2.2.2 Call a radio with an interprefix number

Call the radio having the interprefix number. Have a conversation with the second party.

1.5.2.2.3 Short form dialling

Repeat 1.5.2.2.1 using the short form dialling. Have a conversation with the second party.

1.5.2.2.4 Call the radio under test

Make a call to the radio under test from the other radios.

1.5.2.3 Intersite call

Move the radio under test to a distant site.

Ensure that the radio is registered on that site.

1.5.2.3.1 Call a radio with the same prefix number

Call the radio having the same prefix number. Have a conversation with the second party.

1.5.2.3.2 Call a radio with an interprefix number

Call the radio having the interprefix number. Have a conversation with the second party.

1.5.2.3.3 Short form dialling

Repeat 1.5.2.3.1 using the short form dialling. Have a conversation with the second party.

- 1.5.2.3.4 PSTN call
Call the PSTN telephone. Have a conversation with the second party.
- 1.5.2.3.5 Call the radio under test
Call the radio under test from the other radios. Have a conversation with the second party.
- 1.5.2.3.6 Handoff
Travel between sites and ensure that the radio under test re-register on the different sites.

Note: Call failures must be confirmed through different trunk sites.

2.6 Acoustical Measurements

2.5.1 Receiver loudspeaker sound pressure level

Connect the equipment as shown below.

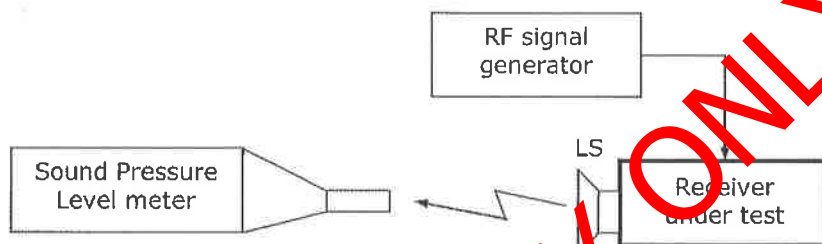

- 2.5.1.1 Adjust the RF signal generator to produce a standard RF test signal.
- 2.5.1.2 Increase the modulation to 2.5 kHz (maximum system modulation).
- 2.5.1.3 Adjust the volume control of the radio to obtain MUOP.
- 2.5.1.4 Place the Sound Pressure Level (SPL) meter at a distance of 300 mm in front of the radio loudspeaker.
- 2.5.1.5 Record the SPL in dB(A).

Note: Sound wave reflections should be kept to a minimum by measuring in an open area.

2.5.2 Transmitter modulation (deviation)

Connect the equipment as shown below.

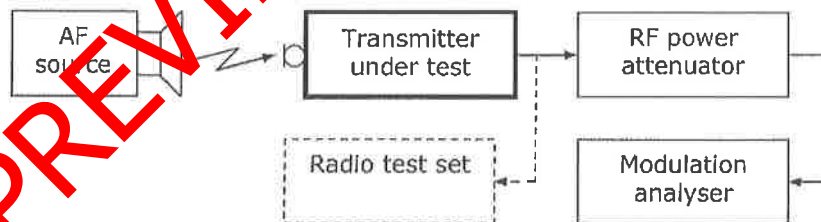

- 2.5.2.1 Ensure that the transmitter modulation limiting has been set correctly (see clauses 2.3.7).
- 2.5.2.2 Generate a 1 kHz tone with the AF source at a level of 80 dB(A), measured at the radio microphone.
- 2.5.2.3 Transmit and record the measured deviation.

Note: Sound wave reflections should be kept to a minimum by measuring in an open area.

**3. RELEVANT DOCUMENTATION
APPLICABLE**

DOCUMENT NO.	DESCRIPTION	LOCATION
SANS 300086-1:2005	Electromagnetic compatibility and Radio Spectrum Matters (ERM); Land Mobile Service; Radio equipment with an internal or external RF connector intended primarily for analogue speech Part 1: Technical characteristics and methods of measurement.	External

RELEVANT

DOCUMENT NO.	DESCRIPTION	LOCATION

END OF DOCUMENT

"PREVIEW COPY ONLY"