

**TRANSNET FREIGHT RAIL** a division of

**TRANSNET SOC LTD**

Registration Number 1990/000900/30

[Hereinafter referred to as **Transnet**]

**REQUEST FOR QUOTATION [RFQ] No: CR/C-EMF-19426**

**FOR THE SUPPLY AND DELIVERY OF: SABS APPROVED LEDFLOOD MAXI  
128/279W HVTA -32 110 M LD AT ELANDSFONTEIN**

**FOR DELIVERY TO: ELANDSFONTEIN DEPOT**

**ISSUE DATE: 29 SEPTEMBER 2015**

**CLOSING DATE: 06 OCTOBER 2015**

**CLOSING TIME: 12:00**

## Section 1

### NOTICE TO BIDDERS

Quotations which must be completed as indicated in Section 2 of this RFQ are to be submitted as follows:

**METHOD:** HAND DELIVERY/ COURIER  
**CLOSING VENUE:** Main Reception Area  
 Transnet Freight Rail  
 Elandsfontein  
 Cnr. Jet Park and North Reef Road  
 1406

#### 1 Responses to RFQ

Responses to this RFQ [**Quotations**] must not include documents or reference relating to any other quotation or proposal. Any additional conditions must be embodied in an accompanying letter.

#### 2 Broad-Based Black Economic Empowerment [B-BBEE]

Transnet fully endorses and supports the Government's Broad-Based Black Economic Empowerment Programme and it would therefore prefer to do business with local business enterprises who share these same values. As described in more detail in the attached B-BBEE Claim Form Transnet will allow a "preference" to companies who provide a valid B-BBEE Verification Certificate.

The value of this bid is estimated to be below R1 000 000 000; and therefore the **80/20** system shall be applicable.

Respondents are required to complete Annexure A [the B-BBEE Preference Point Claim Form] and submit it together with proof of their B-BBEE Status as stipulated in the Claim Form in order to obtain preference points for their B-BBEE status.

**Note: Failure to submit a valid and original B-BBEE certificate or a certified copy thereof at the Closing Date of this RFQ will result in a score of zero being allocated for B-BBEE.**

#### 3 Communication

Respondents are warned that a response will be liable for disqualification should any attempt be made by a Respondent either directly or indirectly to canvass any officer(s) or employee of Transnet in respect of this RFQ between the closing date and the date of the award of the business.

A Respondent may, however, before the closing date and time, direct any written enquiries relating to the RFQ to the following Transnet employee:

Name: Phillip Serage

Email: Phillip.serage@transnet.net

Telephone: 011 878 7236

Respondents may also, at any time after the closing date of the RFQ, communicate with the Secretariat of the Transnet Acquisition Council on any matter relating to its RFQ response:

Telephone 011 878 7045

Email: Tlalane.mokiba@transnet.net

#### **4 Legal Compliance**

The successful Respondent shall be in full and complete compliance with any and all applicable national and local laws and regulations.

#### **5 Changes to Quotations**

Changes by the Respondent to its submission will not be considered after the closing date and time.

#### **6 Pricing**

All prices must be quoted in South African Rand on a fixed price basis, excluding VAT.

#### **7 Prices Subject to Confirmation**

Prices quoted which are subject to confirmation will not be considered.

#### **8 Binding Offer**

Any Quotation furnished pursuant to this Request shall be deemed to be an offer. Any exceptions to this statement must be clearly and specifically indicated.

#### **9 Disclaimers**

Transnet is not committed to any course of action as a result of its issuance of this RFQ and/or its receipt of a Quotation in response to it. Please note that Transnet reserves the right to:

- modify the RFQ's goods / service(s) and request Respondents to re-bid on any changes;
- reject any Quotation which does not conform to instructions and specifications which are detailed herein;
- disqualify Quotations submitted after the stated submission deadline;
- not necessarily accept the lowest priced Quotation or an alternative bid;
- reject all Quotations, if it so decides;
- place an order in connection with this Quotation at any time after the RFQ's closing date;
- award only a portion of the proposed goods / service/s which are reflected in the scope of this RFQ;
- split the award of the order/s between more than one Supplier/Service Provider should it at Transnet's discretion be more advantageous in terms of, amongst others, cost or developmental considerations ;  
or
- Make no award at all.

Should a contract be awarded on the strength of information furnished by the Respondent, which after conclusion of the contract, is proved to have been incorrect, Transnet reserves the right to cancel the contract.

Transnet reserves the right to award business to the highest scoring bidder/s unless objective criteria justify the award to another bidder.

Transnet reserves the right to conduct Post Tender Negotiations (PTN) with selected Respondents or any number of short-listed Respondents, such PTN to include, at Transnet's discretion, any evaluation criteria listed in the RFQ document.

Should the preferred bidder fail to sign or commence with the contract within a reasonable period after being requested to do so, Transnet reserves the right to award the business to the next highest ranked bidder, provided that he/she is still prepared to provide the required goods at the quoted price.

**10 Specification/Scope of Work**

**Transnet urges its clients, suppliers and the general public to report any fraud or corruption to  
TIP-OFFS ANONYMOUS: 0800 003 056**

**"PREVIEW COPY ONLY"**

**Returnable Document**

**RFQ FOR THE SUPPLY AND DELIVERY OF: SABS APPROVED LEDFLOOD MAXI 128/279W  
 HVTA -32 510 LM LD AT ELANDSFONTEIN. TO BE DELIVERED IN ELANDSFONTEIN DEPOT  
 CLOSING VENUE: Main reception Area, Elandsfontein Depot  
 CLOSING DATE & TIME: 12:00 06 OCTOBER 2015  
 VALIDITY PERIOD: 90 Business Days**

**SECTION 2**

**1 EVALUATION CRITERIA**

**2 TRANSNET WILL UTILISE THE FOLLOWING CRITERIA [NOT NECESSARILY IN THIS ORDER] IN CHOOSING A SUPPLIER/SERVICE PROVIDER, IF SO REQUIRED:**

Criterion/Criteria	Explanation
<b>Administrative responsiveness</b>	Completeness of response and returnable documents
<b>Substantive responsiveness</b>	Prequalification criteria, if any, must be met and whether the Bid materially complies with the scope and/or specification given.
<b>Final weighted evaluation based on 80/20 preference point</b>	<ul style="list-style-type: none"> <li>Pricing and price basis [firm]</li> <li>B-BBEE status of company - Preference points will be awarded to a bidder for attaining the B-BBEE status level of contribution in accordance with the table indicated in Annexure A: B-BBEE Claim Form.</li> </ul>

**3 Validity Period**

Transnet desires a validity period of 90 [ninety] Business Days from the closing date of this RFQ. This RFQ is valid until 11 January 2016.

**4 Disclosure of Prices Quoted**

Respondents must indicate here whether Transnet may disclose their quoted prices and conditions to other Respondents:

YES  NO

**5 Returnable Documents**

**Returnable Documents** means all the documents, Sections and Annexures, as listed in the tables below.

**All Returnable Sections, as indicated in the header and footer of the relevant pages, must be signed, stamped and dated by the Respondent.**

- a) Respondents are required to submit with their Quotations the **mandatory Returnable Documents**, as detailed below.

**Returnable Document**

***Failure to provide all these Mandatory Returnable Documents at the Closing Date and time of this RFQ will result in a Respondent's disqualification. Respondents are therefore urged to ensure that all these Documents are returned with their Quotations.***

Please confirm submission of these mandatory Returnable Documents by so indicating [Yes or No] in the tables below:

Mandatory Returnable Documents	Submitted [Yes or No]
SECTION 3 : Quotation Form	

- b) In addition to the requirements of section (a) above, Respondents are further required to submit with their Quotations the following **essential Returnable Documents** as detailed below.

***Failure to provide all these Returnable Documents may result in a Respondent's disqualification. Respondents are therefore urged to ensure that all these documents are returned with their Quotations.***

Essential Returnable Documents	Submitted [Yes or No]
- SECTION 4 : RFQ Declaration and Breach of Law Form	
- Valid and original, or a certified copy, of your entity's B-BBEE Verification Certification as per the requirements stipulated in Annexure A: B-BBEE Claims Form Note: failure to provide these required documents at the closing date and time of the RFQ will result in an automatic score of zero being allocated for preference	
- Original valid Tax Clearance Certificate [Consortia / Joint Ventures must submit a separate Tax Clearance Certificate for each party]	
ANNEXURE A – B-BBEE Preference Points Claim Form	

**CONTINUED VALIDITY OF RETURNABLE DOCUMENTS**

The successful Respondent will be required to ensure the validity of all returnable documents, including but not limited to its Tax Clearance Certificate and valid B-BBEE Verification Certificate, for the duration of any contract emanating from this RFQ. Should the Respondent be awarded the contract [**the Agreement**] and fail to present Transnet with such renewals as and when they become due, Transnet shall be entitled, in addition to any other rights and remedies that it may have in terms of the eventual Agreement, to terminate such Agreement forthwith without any liability and without prejudice to any claims which Transnet may have for damages against the Respondent.

\_\_\_\_\_  
Respondent's Signature

\_\_\_\_\_  
Date & Company Stamp

**Returnable Document**

**SECTION 3  
 QUOTATION FORM**

I/We \_\_\_\_\_  
 Hereby offer to supply the goods/services at the prices quoted in the Price Schedule below, in accordance with the conditions related thereto.

I/We agree to be bound by those terms and conditions in:

- the Standard RFQ Terms and Conditions for the Supply of Goods or Services to Transnet; and
- Any other standard or special conditions mentioned and/or embodied in this Request for Quotation.

I/We accept that unless Transnet should otherwise decide and so inform me/us, this Quotation [and, if any, its covering letter and any subsequent exchange of correspondence], together with Transnet's acceptance thereof shall constitute a binding contract between Transnet and me/us.

I/We further agree that if, after I/we have been notified of the acceptance of my/our Quotation, I/we fail to deliver the said goods/service/s within the delivery lead-time quoted, Transnet may, without prejudice to any other legal remedy which it may have, cancel the order and recover from me/us any expenses incurred by Transnet in calling for Quotations and/or having to accept any less favourable offer.

**Price Schedule**

I/We quote as follows for the goods required, on a "delivered nominated destination" basis, excluding VAT:

Item No	Description of Goods / Services	Unit of Measure	Quantity	Unit Price (ZAR)	Total Price (ZAR)
1	SABS APPROVED LEDFLOOD MAXI 128/279W HVTA -32 510LM LD	EA	103		
	<b>TOTAL</b>				

**Delivery Lead-Time from date of purchase order:** \_\_\_\_\_ [days/weeks]

**Notes to Pricing:**

- All Prices must be quoted in South African Rand, exclusive of VAT
- To facilitate like-for-like comparison bidders must submit pricing strictly in accordance with this price schedule and not utilise a different format. Deviation from this pricing schedule could result in a bid being disqualified.

Please note that should you have offered a discounted price(s), Transnet will only consider such price discount(s) in the final evaluation stage if offered on an unconditional basis.

**By signing this Quotation Form the Respondent is deemed to acknowledge that he/she has made himself/herself thoroughly familiar, and agrees, with all the conditions governing this RFQ, including those contained in any printed form stated to form part hereof, including but not limited**

\_\_\_\_\_  
 Respondent's Signature

\_\_\_\_\_  
 Date & Company Stamp

**Returnable Document**

**to the documents stated below and Transnet SOC Ltd will recognise no claim for relief based on an allegation that the Respondent overlooked any such condition or failed properly to take it into account for the purpose of calculating tendered prices or otherwise:**

1. Specifications and drawings included in this RFQ - if applicable; and
2. The following documents all of which are available on Transnet's website or upon request:
  - 2.1. General Bid Conditions;
  - 2.2. Standard RFQ Terms and Conditions for the Supply of Goods or Services to Transnet;
  - 2.3. Supplier Integrity Pact;
  - 2.4. Non-disclosure Agreement; and
  - 2.5. Vendor Application Form and all supporting documents (first time vendors only)Alternatively, for all existing vendors, please provide vendor number(s) here:

<b>Transnet Operating Division</b>	<b>Unique Vendor Number</b>	<b>Yes / No</b>
Transnet Group		
TFR, etc.		

In the Yes/No column above, please confirm that all the information e.g. company address and contact details, banking details etc. are still correct as at the time of allocation of the vendor number(s). Alternatively, Respondents are required to provide the updated information with their bid submission.

**"PREVIEW COPY ONLY"**



**Returnable Document**

SIGNED at \_\_\_\_\_ on this \_\_\_\_ day of \_\_\_\_\_ 20\_\_

SIGNATURE OF WITNESSES

ADDRESS OF WITNESSES

1 \_\_\_\_\_  
Name \_\_\_\_\_

\_\_\_\_\_  
\_\_\_\_\_

2 \_\_\_\_\_  
Name \_\_\_\_\_

\_\_\_\_\_  
\_\_\_\_\_

SIGNATURE OF RESPONDENT'S AUTHORISED REPRESENTATIVE: \_\_\_\_\_

NAME: \_\_\_\_\_

DESIGNATION: \_\_\_\_\_

**"PREVIEW COPY ONLY"**

\_\_\_\_\_  
Respondent's Signature

\_\_\_\_\_  
Date & Company Stamp

**Returnable Document**

**SECTION 4**

**RFQ DECLARATION AND BREACH OF LAW FORM**

NAME OF ENTITY: \_\_\_\_\_

We \_\_\_\_\_ do hereby certify that:

1. Transnet has supplied and we have received appropriate responses to any/all questions [as applicable] which were submitted by ourselves for RFQ Clarification purposes;
2. we have received all information we deemed necessary for the completion of this Request for Quotation [RFQ];
3. We have been provided with sufficient access to the existing Transnet facilities/sites and any and all relevant information relevant to the Supply of the Goods as well as Transnet information and Employees, and has had sufficient time in which to conduct and perform a thorough due diligence of Transnet's operations and business requirements and assets used by Transnet. Transnet will therefore not consider or permit any pre- or post-contract verification or any related adjustment to pricing, service levels or any other provisions/conditions based on any incorrect assumptions made by the Respondent in arriving at his Bid Price.
4. at no stage have we received additional information relating to the subject matter of this RFQ from Transnet sources other than information formally received from the designated Transnet contact(s) as nominated in the RFQ documents;
5. we are satisfied, insofar as our entity is concerned, that the processes and procedures adopted by Transnet in issuing this RFQ and the requirements requested from Bidders in responding to this RFQ have been conducted in a fair and transparent manner; and
6. Furthermore, we declare that a family, business and/or social relationship **exists / does not exist** [delete as applicable] between an owner / member / director / partner / shareholder of our entity and an employee or board member of the Transnet Group including any person who may be involved in the evaluation and/or adjudication of this Bid.
7. In addition, we declare that an owner / member / director / partner / shareholder of our entity **is / is not** [delete as applicable] an employee or board member of the Transnet Group.
8. If such a relationship as indicated in paragraph 6 and/or 7 exists, the Respondent is to complete the following section:

\_\_\_\_\_  
Respondent's Signature

\_\_\_\_\_  
Date & Company Stamp

**Returnable Document**

FULL NAME OF OWNER/MEMBER/DIRECTOR/  
PARTNER/SHAREHOLDER:

ADDRESS:

---

---

Indicate nature of relationship with Transnet:

---

---

*[Failure to furnish complete and accurate information in this regard will lead to the disqualification of a response and may preclude a Respondent from doing future business with Transnet]*

9. We declare, to the extent that we are aware or become aware of any relationship between ourselves and Transnet [other than any existing and appropriate business relationship with Transnet] which could unfairly advantage our entity in the forthcoming adjudication process, we shall notify Transnet immediately in writing of such circumstances.

**BREACH OF LAW**

10. We further hereby certify that *I/we have/have not been* [delete as applicable] found guilty during the preceding 5 [five] years of a serious breach of law, including but not limited to a breach of the Competition Act, 89 of 1998, by a court of law, tribunal or other administrative body. The type of breach that the Respondent is required to disclose excludes relatively minor offences or misdemeanours, e.g. traffic offences. This includes the imposition of an administrative fine or penalty.

Where found guilty of such a serious breach, please disclose:

NATURE OF BREACH:

---

---

---

DATE OF BREACH: \_\_\_\_\_

Furthermore, I/we acknowledge that Transnet SOC Ltd reserves the right to exclude any Respondent from the bidding process, should that person or entity have been found guilty of a serious breach of law, tribunal or regulatory obligation.

**Returnable Document**

SIGNED at \_\_\_\_\_ on this \_\_\_\_\_ day of \_\_\_\_\_ 20\_\_

For and on behalf of _____ duly authorised hereto	AS WITNESS:
Name:	Name:
Position:	Position:
Signature:	Signature:
Date:	Registration No of Company/CC _____
Place:	Registration Name of Company/CC _____

**"PREVIEW COPY ONLY"**

\_\_\_\_\_  
Respondent's Signature

\_\_\_\_\_  
Date & Company Stamp

**FOR THE SUPPLY AND DELIVERY OF: SABS APPROVED LEDFLOOD MAXI 128/279W  
HVTA -32 510 LM LD AT ELANDSFONTEIN**

**ANNEXURE A: B-BBEE PREFERENCE POINTS CLAIM FORM**

This preference form contains general information and serves as a claim for preference points for Broad-Based Black Economic Empowerment [**B-BBEE**] Status Level of Contribution.

**1. INTRODUCTION**

- 1.1 A total of 20 (Twenty) preference points shall be awarded for B-BBEE Status Level of Contribution.
- 1.2 Failure on the part of a Bidder to fill in and/or to sign this form and submit a B-BBEE Verification Certificate from a Verification Agency accredited by the South African Accreditation System [**SANAS**] or a Registered Auditor approved by the Independent Regulatory Board of Auditors [**IRBA**] or an Accounting Officer as contemplated in the Close Corporation Act [**CCA**] together with the bid will be interpreted to mean that preference points for B-BBEE Status Level of Contribution are not claimed.
- 1.3 Transnet reserves the right to require of a Bidder, either before a Bid is adjudicated or at any time subsequently, to substantiate any claim in regard to preferences, in any manner required by Transnet.

**2. GENERAL DEFINITIONS**

- 2.1 "**all applicable taxes**" include value-added tax, pay as you earn, income tax, unemployment insurance fund contributions and skills development levies;
- 2.2 "**B-BBEE**" means broad-based black economic empowerment as defined in section 1 of the Broad-Based Black Economic Empowerment Act;
- 2.3 "**B-BBEE status of contributor**" means the B-BBEE status received by a measured entity based on its overall performance using the relevant scorecard contained in the Codes of Good Practice on Black Economic Empowerment, issued in terms of section 9(1) of the Broad-Based Black Economic Empowerment Act;
- 2.4 "**Bid**" means a written offer in a prescribed or stipulated form in response to an invitation by Transnet for the provision of goods, works or services;
- 2.5 "**Broad-Based Black Economic Empowerment Act**" means the Broad-Based Black Economic Empowerment Act, 2003 [Act No. 53 of 2003];
- 2.6 "**comparative price**" means the price after the factors of a non-firm price and all unconditional discounts that can be utilised have been taken into consideration;
- 2.7 "**consortium or joint venture**" means an association of persons for the purpose of combining their expertise, property, capital, efforts, skills and knowledge in an activity for the execution of a contract;

- 2.8 **"contract"** means the agreement that results from the acceptance of a bid by Transnet;
- 2.9 **"EME"** means any enterprise with an annual total revenue of R5 [five] million or less as per the 2007 version of the B-BBEE Codes of Good Practice and means any enterprise with an annual total revenue of R10 [ten] million or less as per the Revised Codes of Good Practice issued on 11 October 2013 in terms of Government Gazette No. 36928;
- 2.10 **"firm price"** means the price that is only subject to adjustments in accordance with the actual increase or decrease resulting from the change, imposition, or abolition of customs and excise duty and any other duty, levy, or tax, which, in terms of the law or regulation, is binding on the contractor and demonstrably has an influence on the price of any supplies, or the rendering costs of any service, for the execution of the contract;
- 2.11 **"functionality"** means the measurement according to predetermined norms, as set out in the bid documents, of a service or commodity that is designed to be practical and useful, working or operating, taking into account, among other factors, the quality, reliability, viability and durability of a service and the technical capacity and ability of a bidder;
- 2.12 **"non-firm prices"** means all prices other than "firm" prices;
- 2.13 **"person"** includes reference to a juristic person;
- 2.14 **"QSE"** means any enterprise with an annual total revenue between R5 [five] million and R35 [thirty five] million as per the 2007 version of the B-BBEE Codes of Good Practice and means any enterprise with an annual total revenue of between R10 [ten] million and R50 [fifty] million as per the Revised Codes of Good Practice issued on 11 October 2013 in terms of Government Gazette No. 36928
- 2.15 **"rand value"** means the total estimated value of a contract in South African currency, calculated at the time of bid invitations, and includes all applicable taxes and excise duties;
- 2.16 **"subcontract"** means the primary contractor's assigning or leasing or making out work to, or employing another person to support such primary contractor in the execution of part of a project in terms of the contract;
- 2.17 **"total revenue"** bears the same meaning assigned to this expression in the Codes of Good Practice on Black Economic Empowerment, issued in terms of section 9(1) of the Broad-Based Black Empowerment Act and promulgated in the Government Gazette on 9 February 2007;
- 2.18 **"trust"** means the arrangement through which the property of one person is made over or bequeathed to a trustee to administer such property for the benefit of another person; and
- 2.19 **"trustee"** means any person, including the founder of a trust, to whom property is bequeathed in order for such property to be administered for the benefit of another person.

### 3. ADJUDICATION USING A POINT SYSTEM

- 3.1 The Bidder obtaining the highest number of total points for the evaluation criteria as enumerated in Section 2 of the RFP will be awarded the contract, unless objective criteria justifies the award to another bidder.
- 3.2 Preference points shall be calculated after prices have been brought to a comparative basis taking into account all factors of non-firm prices and all unconditional discounts.

- 3.3 Points scored will be rounded off to 2 [two] decimal places.
- 3.4 In the event of equal points scored, the Bid will be awarded to the Bidder scoring the highest number of preference points for B-BBEE.
- 3.5 However, when functionality is part of the evaluation process and two or more Bids have scored equal points including equal preference points for B-BBEE, the successful Bid will be the one scoring the highest score for functionality.
- 3.6 Should two or more Bids be equal in all respect, the award shall be decided by the drawing of lots.

**"PREVIEW COPY ONLY"**

#### 4. POINTS AWARDED FOR B-BBEE STATUS LEVEL OF CONTRIBUTION

- 4.1 In terms of the Preferential Procurement Regulations, 2011, preference points shall be awarded to a Bidder for attaining the B-BBEE status level of contribution in accordance with the table below:

B-BBEE Status Level of Contributor	Number of Points [Maximum 20]
1	20
2	18
3	16
4	12
5	8
6	6
7	4
8	2
Non-compliant contributor	0

- 4.2 Bidders who qualify as EMEs in terms of the 2007 version of the Codes of Good Practice must submit a certificate issued by an Accounting Officer as contemplated in the CCA or a Verification Agency accredited by SANAS or a Registered Auditor. Registered auditors do not need to meet the prerequisite for IRBA's approval for the purpose of conducting verification and issuing EME's with B-BBEE Status Level Certificates.
- 4.3 Bidders who qualify as EMEs in terms of the Revised Codes of Good Practice issued on 11 October 2013 in terms of Government Gazette No. 36928 are only required to obtain a sworn affidavit on an annual basis confirming that the entity has an Annual Total Revenue of R10 million or less and the entity's Level of Black ownership.
- 4.4 In terms of the 2007 version of the Codes of Good Practice, Bidders other than EMEs must submit their original and valid B-BBEE status level verification certificate or a certified copy thereof, substantiating their B-BBEE rating issued by a Registered Auditor approved by IRBA or a Verification Agency accredited by SANAS.
- 4.5 In terms of the Revised Codes of Good Practice issued on 11 October 2013 in terms of Government Gazette No. 36928, Bidders who qualify as QSEs are only required to obtain a sworn affidavit on an annual basis confirming that the entity has an Annual Total Revenue of R50 million or less and the entity's Level of Black ownership. Large enterprises must submit their original and valid B-BBEE status level verification certificate or a certified copy thereof, substantiating their B-BBEE rating issued by a Registered Auditor approved by IRBA or a Verification Agency accredited by SANAS.
- 4.6 A trust, consortium or joint venture will qualify for points for its B-BBEE status level as a legal entity, provided that the entity submits its B-BBEE status level certificate.
- 4.7 A trust, consortium or joint venture will qualify for points for their B-BBEE status level as an unincorporated entity, provided that the entity submits their consolidated B-BBEE scorecard as if they were a group structure and that such a consolidated B-BBEE scorecard is prepared for every separate bid.
- 4.8 Tertiary institutions and public entities will be required to submit their B-BBEE status level



certificates in terms of the specialised scorecard contained in the B-BBEE Codes of Good Practice.

- 4.9 A person will not be awarded points for B-BBEE status level if it is indicated in the Bid documents that such a Bidder intends subcontracting more than 25% [twenty-five per cent] of the value of the contract to any other enterprise that does not qualify for at least the same number of points that such a Bidder qualifies for, unless the intended subcontractor is an EME that has the capability and ability to execute the subcontract.
- 4.10 A person awarded a contract may not subcontract more than 25% [twenty-five per cent] of the value of the contract to any other enterprise that does not have an equal or higher B-BBEE status level than the person concerned, unless the contract is subcontracted to an EME that has the capability and ability to execute the subcontract.
- 4.11 Bidders are to note that in terms of paragraph 2.6 of Statement 000 of the Revised Codes of Good Practice issued on 11 October 2013 in terms of Government Gazette No. 36928, any representation made by an entity about its B-BBEE compliance must be supported by suitable evidence or documentation. As such, Transnet reserves the right to request such evidence or documentation from Bidders in order to verify any B-BBEE recognition claimed.

**5. B-BBEE STATUS AND SUBCONTRACTING**

**5.1 Bidders who claim points in respect of B-BBEE Status Level of Contribution must complete the following:**

B-BBEE Status Level of Contributor \_\_\_\_\_ = \_\_\_\_\_ [maximum of 20 points]

Note: Points claimed in respect of this paragraph 5.1 must be in accordance with the table reflected in paragraph 4.1 above and must be substantiated by means of a B-BBEE certificate issued by a Verification Agency accredited by SANAS or a Registered Auditor approved by IRBA or a sworn affidavit in the case of an EME or QSE.

**5.2 Subcontracting:**

Will any portion of the contract be subcontracted? YES/NO [delete which is not applicable]

If YES, indicate:

- (i) What percentage of the contract will be subcontracted? .....
- (ii) The name of the subcontractor .....
- (iii) The B-BBEE status level of the subcontractor .....
- (iv) Is the subcontractor an EME? YES/NO

**5.3 Declaration with regard to Company/Firm**

- (i) Name of Company/Firm.....
- (ii) VAT registration number.....
- (iii) Company registration number.....
- (iv) Type of Company / Firm [TICK APPLICABLE BOX]

- Partnership/Joint Venture/Consortium
- One person business/sole propriety
- Close Corporations

Company (Pty) Ltd

(v) Describe Principal Business Activities

.....  
.....  
.....

(vi) Company Classification [TICK APPLICABLE BOX]

Manufacturer

Supplier

Professional Service Provider

Other Service Providers, e.g Transporter, etc

(vii) Total number of years the company/firm has been in business.....

**BID DECLARATION**

I/we, the undersigned, who warrants that he/she is duly authorised to do so on behalf of the company/firm, certify that points claimed, based on the B-BBEE status level of contribution indicated in paragraph 4 above, qualifies the company/firm for the preference(s) shown and I / we acknowledge that:

- (i) The information furnished is true and correct.
- (ii) In the event of a contract being awarded as a result of points claimed as shown in paragraph 6 above, the contractor may be required to furnish documentary proof to the satisfaction of Transnet that the claims are correct.
- (iii) If the B-BBEE status level of contribution has been claimed or obtained on a fraudulent basis or any of the conditions of contract have not been fulfilled, Transnet may, in addition to any other remedy it may have:
  - (a) disqualify the person from the bidding process;
  - (b) recover costs, losses or damages it has incurred or suffered as a result of that person's conduct;
  - (c) cancel the contract and claim any damages which it has suffered as a result of having to make less favourable arrangements due to such cancellation;
  - (d) restrict the Bidder or contractor, its shareholders and directors, and/or associated entities, or only the shareholders and directors who acted in a fraudulent manner, from obtaining business from Transnet for a period not exceeding 10 years, after the *audi alteram partem* [hear the other side] rule has been applied; and/or
  - (e) forward the matter for criminal prosecution.

"PREVIEW COPY ONLY"

**WITNESSES:**

- 1. ....
- 2. ....

SIGNATURE OF BIDDER
---------------------

DATE:.....

COMPANY NAME: .....

ADDRESS:.....

**"PREVIEW COPY ONLY"**

- Designed to operate LED light sources of up to 279W in an average ambient temperature environment of up to 35°C, without reducing the useful lifetime of 60 000 hours, at a lumen depreciation of not more than 20% (L80)
- Easy to install
- No lamp or component replacements for more than 10 years
- Designed for easy technology upgrade (FutureProof)
- Marine grade, high-pressure die-cast aluminium housing
- Designed to replace conventional HID and CFL streetlight and floodlight luminaires (up to 400W HPS) with energy savings up to 70%
- Three-compartment housing, ensures reliable ingress protection
- Automatic disconnection of power when opened

LEDflood-maxi

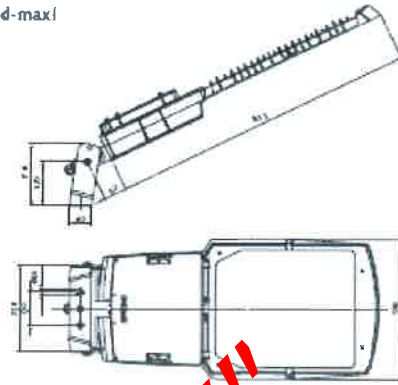

LED FLOOD-MAXI

OVERVIEW

Number of LEDs	Neutral white (4000K)	80 LEDs		96 LEDs		128 LEDs	
		Nominal flux (lm)*	20320	24380	32510	Lifetime residual flux @ t <sub>a</sub> 25°C**	@100.000h
Current: 700mA	Power consumption (W)	180	213	279	90%	70%	

\* The nominal flux is an indicative LED flux @ t<sub>a</sub> 25°C based on LED manufacturer's data. The real flux output of the luminaire depends on environmental conditions (e.g. temperature and pollution) and the optical efficiency of luminaire.

\*\* The type of LED used is subject to change due to the ongoing rapid progress taking place in LED technology.

\*\*\* In accordance with LM-80 – TM-21

LIGHT DISTRIBUTIONS

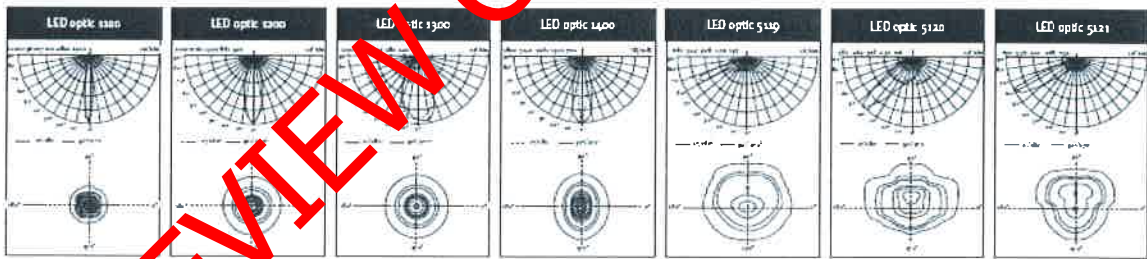

ORDERING DATA

DESCRIPTION	LEDS	CURRENT (mA)	LUMEN	MASS (KG)
LEDflood-midi 55W	24	700	6 192	10,4
LEDflood-midi 75W	32	700	8 256	10,5
LEDflood-midi 108W	48	700	12 884	10,5
LEDflood-midi 144W*	64	700	16 512	15,5
LEDflood-maxi 180W	80	700	20 320	15,9
LEDflood-maxi 213W	96	700	24 380	16,1
LEDflood-maxi 279W*	128	700	32 510	16,5

\*Only for downward lighting

Standard optic: 5120 - wide area

Standard finish: Unpainted aluminium