



RFQ / TENDER

Tender No: CRAC-19269

Vendor No: 11001386

BOARD LIST
BOARD LIST
TRANSNET FREIGHT RAIL
PROCUREMENT DEPARTMENT
2000

Purchaser : Alex Baloyi
Telephone : 011 584 1425
Fax Number:

Please quote reference:
D89/6000616558

Deliver to:
TFR Head Office
Supply Chain Services
2000 Johannesburg

Closing Date : 29.09.2015
Validity Date : 31.12.2015
RFQ No : 6000616558

PROVISION OF SUPPLY AND DELIVERY OF HANDHELD AND CONVECTIONAL RADIO AT HEIDELBERG DEPOT

*EXT NAME: RFQ 9 STANDARD H

1. RETURN OF QUOTATION

PLEASE SEND TO FAX NUMBER 011 774-9129, 011 774 9186

EMAIL: thuli.mathebula@transnet.net, lolo.sokhela@transnet.net

1.1 QUOTATIONS MUST BE SUBMITTED PUNCTUALLY AT 10:00 ON THE CLOSING DATE AND LATE QUOTATIONS WILL NOT BE CONSIDERED.

1.2 IF POSSIBLE:

EXECUTIVE MANAGER (TRANSNET FREIGHT RAIL, SUPPLY CHAIN SERVICES)
PO BOX 8617
JOHANNESBURG
2000

1.3 ,IF DELIVERED BY HAND:

TRANSNET FREIGHT RAIL
INYANDA HOUSE 1
21 WILLINGTON ROAD
PARKTOWN
JOHANNESBURG
2001

2. CONDITIONS:

2.2 ANY PURCHASE ORDER PLACED AS A RESULT OF YOUR QUOTATION WILL BE SUBJECT TO THE STANDARD TERMS AND CONDITIONS OF CONTRACT, FORM US7, (LATEST), GENERAL TENDER CONDITIONS, FORM CSS5 (LATEST) AND CONDITIONS MENTIONED HEREIN.

2.3 TENDERERS MAY OFFER AN EARLIER VALIDITY DATE, BUT THEIR QUOTATION MAY, IN THAT EVENT, BE DISREGARDED FOR THIS REASON.

DATE: SIGNATURE OF TENDERER(S):

CONTACT PERSON: TEL No:

RFQ / TENDER

Tender No: CRAC-19269 Page
Date : 16.09.2015 2

BOARD LIST
TRANSNET FREIGHT RAIL
PROCUREMENT DEPARTMENT

- 2.4 TENDERERS ARE REQUIRED TO OFFER ONLY FIRM PRICES. PRICES SUBJECT TO REVIEW IN TERMS OF CLAUSE 32 OF FORM US7 WILL ONLY BE CONSIDERED SHOULD THE DELIVERY PERIOD REQUIRED EXCEED 6 MONTHS.
- 2.5 BEST DELIVERY TIME MUST BE OFFERED.
- 2.6 DISCOUNT (TRADE DISCOUNT) CASH DISCOUNT (CONDITONAL DISCOUNT) VALUE ADDED TAX (VAT) MUST BE SHOWN SEPARATELY.
- 2.7 TRANSNET RESERVES THE RIGHT TO NEGOTIATE PRICES AND COMMERCIAL ASPECTS AFTER THE CLOSING DATE OF THE QUOTATION.

"PREVIEW COPY ONLY"

DATE:

SIGNATURE OF TENDERER(S):

RFQ / TENDER

Tender No: CRAC-19269 Page
Date : 16.09.2015 3

BOARD LIST
TRANSNET FREIGHT RAIL
PROCUREMENT DEPARTMENT

2.8 DIRECT DELIVERY INTIMATES DELIVERY BEING EFFECTED INTO THE WAREHOUSE OR THE ACTUAL POINT OF SUPPLY AND SHOULD THEREFORE INCLUDE ANY TRANSPORTATION MODE DEEMED NECESSARY IN EXECUTING THIS METHOD OF DELIVERY BASIS IN ORDER TO MEET THE REQUIRED DELIVERY DATE.

TAX CLEARANCE CERTIFICATES:

The Regulations in terms of the Public Finance Management Act, 1999: Framework for Supply Chain Management as published in Government Gazette No. 25767 dated 5 December 2003, Clause 9 (1) (d), stipulates that the accounting officer or accounting authority of an institution to which these regulations apply must reject any bid from a supplier who fails to provide written proof from the South African Revenue that the supplier either has no outstanding tax obligations or has made arrangements to meet outstanding tax obligations.

Tenderers will be disqualified if a valid tax clearance certificate or written proof from the South African Revenue Service that supplier has made arrangements to meet outstanding tax obligations is not submitted with the tender.

COMPANY DETAILS:

NAME OF COMPANY: _____
CONTACT PERSON: _____
TEL. NO. _____ FAX NO: _____
REG. NO. _____
EMAIL ADDRESS: _____

BROAD BASED BLACK ECONOMIC EMPOWERMENT (BBBEE)

Transnet fully endorses and supports the Government's Broad-based Black Economic Empowerment Programme and it is strongly of the opinion that all South African Business Enterprises have an equal obligation to redress the imbalances of the past. Transnet will therefore prefer to do business with local business enterprises who share these same values. Transnet will endeavour to do business with local business enterprises that possess a BBBEE "recognition level" of at least a level 5. Transnet urges Tenderers (large enterprises and QSE's - see below) to have themselves accredited by any one of the various Accreditation Agencies available, who do their BBBEE ratings in accordance with the latest Codes (i.e. those promulgated on 9 February 2007) and whose names appear on the present ABVA (Association of BBBEE Verification Agencies) - "List of Full Members" as displayed on the ABVA website (www.abva.co.za). Although no agencies have, as yet, been accredited by SANAS (SA National Accreditation System), Transnet will, in the interim, accept rating certificates of tenderers who have been verified by any of the listed agencies.

Enterprises will be rated by such agency based on the following:

1. Large Enterprises (i.e. annual turnover >R35million:
" Rating level based on all seven elements of the BBBEE scorecard.
2. Qualifying Small Enterprises - (QSE) (i.e. annual turnover >R5million but <R35million:
" Rating based on any four elements of the BBBEE scorecard.

NB:

3. Emerging Micro Enterprises - (EME) (i.e. annual turnover <R5m) are exempted from being rated/verified:
" Automatic rating of Level 4 BBBEE irrespective of race of ownership, i.e. 100% BBBEE recognition
" Black ownership >50% or Black Women ownership >30% automatically qualifies as Level 3 BBBEE, i.e. 110% BBBEE recognition
" EME's should provide certified documentary proof of annual turnover (i.e. audited financials) plus proof of Black ownership if Black ownership >50% or Black Women ownership >30% from the EME's Auditor/Accounting Officer.

4. In addition to the above, Tenderers who wish to enter into a Joint Venture or subcontract portions of the contract to BBBEE companies, must state in their tenders the percentage of the total contract value that will be allocated to such BBBEE companies, should they be successful

DATE:

SIGNATURE OF TENDERER(S):

RFQ / TENDER

Tender No: CRAC-19269 Page
Date : 16.09.2015 4

BOARD LIST
TRANSNET FREIGHT RAIL
PROCUREMENT DEPARTMENT

in being awarded any business. A rating certificate in respect of such BBBEE JV-partners and / or sub-contractor/s, as well as a breakdown of the distribution of the aforementioned percentage must also be furnished

In view of the high emphasis which Transnet places on Broad-based Black Economic Empowerment, Transnet will allow certain preference points for BBBEE in the evaluation of all responses. Depending upon the value of the ensuing business award (i.e. below or in excess of R2m), the 80/20 or 90/10 point preference systems will be utilized where BBBEE will count out of 20 or 10 respectively in the evaluation process.

EACH RESPONDENT IS REQUIRED TO FURNISH PROOF OF THE ABOVE TO TRANSNET. FAILURE TO DO SO WILL RESULT IN A SCORE OF ZERO BEING ALLOCATED FOR BBBEE.

Turnover: Kindly indicate your company's annual turnover for the past year R_____

" If annual turnover <R5m, please attach certified confirmation from your Auditor/Accounting Officer

" If annual turnover >R5m please attach original or certified copy of accreditation certificate and detailed scorecard by an ABVA accreditation agency (registered as a "Full Member")

PAYMENT TERMS

The following payment terms will apply as from 1 October 2008.

" All suppliers will be paid 30 days from receipt of approved end statement, i.e. payment term F055.

CONDITIONS:

This quotation is subject to the provision of the Standard Terms and Conditions of Contract, Form US7, (Latest) and the General Tender Conditions, Form CSS5 (Latest) and any other standard or special conditions mentioned and/or embodied in the quotation request.

SCHEDULE OF REQUIREMENTS

PRICES TENDERED ARE TO BE "DIRECT" AND EXCLUDE VAT.

IN THIS REGARD THE TENDERER'S ATTENTION IS DIRECTED TO PARAGRAPH 16 OF FORM CSS5 (LATEST).

DATE:

SIGNATURE OF TENDERER(S):

RFQ / TENDER

Tender No: CRAC-19269 Page
Date : 16.09.2015 5

BOARD LIST
TRANSNET FREIGHT RAIL
PROCUREMENT DEPARTMENT

TRANSNET INSISTS ON HONESTY AND INTEGRITY BEYOND REPROACH AT ALL TIMES AND WILL NOT TOLERATE ANY FORM OF IMPROPER INFLUENCING, BRIBERY, CORRUPTION, FRAUD, OR ANY OTHER UNETHICAL CONDUCT ON THE PART OF BIDDERS/ TRANSNET EMPLOYEES. IF, IN THE OPINION OF TRANSNET'S CHIEF OPERATING OFFICER, A TENDERER / CONTRACTOR / SUPPLIER HAS OR HAS CAUSED TO BE PROMISED, OFFERED OR GIVEN TO ANY TRANSNET EMPLOYEE, ANY BRIBE, COMMISSION, GIFT, LOAN, ADVANTAGE OR OTHER COSIDERATION, TRANSNET SHALL BE ENTITLED TO REVOKE THE TENDER / CONTRACT BY FOLLOWING ITS INTERNAL POLICIES THAT GOVERN THE ECLUSION PROCES. IN SUCH AN EVENT TRANSNET WILL BE ENTITLED TO PLACE ANY TENDERER / CONTRACTOR / SUPPLIER WHO HAS CONTRAVENED THE PROVISIONS OF TRANSNET'S BUSINESS ETHICS ON ITS LIST OF EXCLUDED TENDERERS. THIS LIST WILL ALSO BE DISTRIBUTED TO ALL OTHER STATE OWNED ENTERPRISES AND GOVERNMENT DEPARTMENTS.

TRANSNET INVITES ITS VALUED SUPPLIERS TO REPORT ANY ALLEGATIONS OF BRIBERY, CORRUPTION OR OTHER UNETHICAL ACTIVITIES TO TRANSNET TIP-OFFS ANONYMOUS, AT ANY OF THE FOLLOWING ADDRESSES / CONTACT NUMBERS:-

TOLL-FREE ANONYMOUS HOTLINE - 0800 003 056
EMAIL - Transnet@tip-offs.com
FAX NUMBER - 0800 007 788
FREEPOST DN 298, UMHLANGA ROCKS, 4320

CONFIDENTIALITY IS QUARANTEED

Item	Qty	Material	Description
00010	3	supply & delivery hand&convectonal radi	

R.....
Each

Delivery Date: 15.10.2015

FULL DETAILS OF DESCRIPTION

DATE:

SIGNATURE OF TENDERER(S):

RFQ / TENDER

Tender No: CRAC-19269
Date : 16.09.2015

Page
6

BOARD LIST
TRANSNET FREIGHT RAIL
PROCUREMENT DEPARTMENT

3. ADDITIONAL INFORMATION REQUIRED: (WHERE APPLICABLE)

3.1 THE FOLLOWING ADDITIONAL INFORMATION IS REQUIRED:

- (A) DISCOUNT:
- (B) SETTLEMENT DISCOUNT:
- (C) PRICE/S FIRM:
- (D) PRICE/S FIRM UNTIL THEREAFTER SUBJECT TO REVIEW.
- (E) PRICE/S NOT FIRM:
- (F) SABS MARK:
- (G) SABS PERMIT NO:
- (H) BRAND/MAKE/TYPE:
- (I) FULL NAME AND ADDRESS OF MANUFACTURER:

- (J) FULL NAME AND ADDRESS OF INSPECTION POINT:

- (K) COUNTRY OF ORIGIN:

Comply : _____ Does not Comply : _____ Not applicable : _____

Justification :

- (L) SURPLUS MATERIAL:
TENDERERS MUST INDICATE IF THEY WILL BE PREPARED TO PURCHASE BACK FROM TRANSNET ANY SURPLUS MATERIAL WHICH MAY BECOME AVAILABLE FROM ANY RESULTING PURCHASE ORDER/CONTRACT ORIGINATED FROM THE QUOTATION SUBMITTED:

- (M) PAYMENT OVERSEAS:
ONLY IF TRANSNET LIMITED IS REQUESTED BY THE TENDERER TO EFFECT PAYMENT OVERSEAS DIRECT TO THE TENDERER'S PRINCIPAL/SUPPLIER THE FOLLOWING INFORMATION IS REQUIRED:

* EXCHANGE RATE ON WHICH THE QUOTATION PRICE IS BASED: R1,00 (S.A. CURRENCY) BEING EQUAL TO (FOREIGN CURRENCY)

* PERCENTAGE IN RELATION TO THE QUOTATION PRICE TO BE REMITTED OVERSEAS:
.....

* NAME OF COUNTRY TO WHICH PAYMENT IS TO BE MADE:
.....
.....

* APPLICABLE DATE OF EXCHANGE RATE:
.....

* BENEFICIARY'S NAME AND FULL ADDRESS:
.....
.....

DATE:

SIGNATURE OF TENDERER(S):

RFQ / TENDER

Tender No: CRAC-19269 Page
Date : 16.09.2015 7

BOARD LIST
TRANSNET FREIGHT RAIL
PROCUREMENT DEPARTMENT

.....
* BENEFICIARY'S BANKERS AND FULL ADDRESS:
.....
.....
.....

* APPLICABLE ACCOUNT NUMBER:
.....

(N) DELIVERY DATE:

TENDERERS MUST FURNISH THEIR ACTUAL DELIVERY AND MANUFACTURING PERIOD HEREUNDER NOTWITHSTANDING THE DELIVERY DATES SPECIFIED BY TRANSNET.

THE FOLLOWING MUST ALSO BE FURNISHED IN REGARD TO THE ABOVE:

1. PERIOD REQUIRED TO OBTAIN RAW MATERIAL.(DAYS)
2. MANUFACTURING PERIOD.(DAYS)
3. PERIOD TO TRANSPORT MATERIAL TO DESTINATION.(DAYS)

MATERIAL NO.	1.(PERIOD)	2.(PERIOD)	3.(PERIOD)
.....
.....
.....
.....
.....
.....

INDICATE THE PERCENTAGE (% OF THE PRICE THAT IS SUBJECT TO THE VARIABLE COPPER FEE:%.

"PREVIEW COPY ONLY"

DATE:

SIGNATURE OF TENDERER(S):

CRAC-JHB-19269 PROVISION OF SUPPLY AND DELIVERY OF HANDHELD AND CONVECTIONAL RADIO'S



EVALUATION CRITERIA

Transnet will utilise the following criteria [not necessarily in this order] in choosing a Supplier/Service Provider, if so required:

Criterion/Criteria	Explanation
Administrative responsiveness	Completeness of response and returnable documents All the returnable document at paragraph 19,section 1
Substantive responsiveness	<ul style="list-style-type: none"> Compliance to specification in line with scope of work and schedule of quantities <p>NB: Bidders must fully comply to the scope to move to the next stage(pricing)</p>
Final weighted evaluation based on 80/20 preference point system as indicated in paragraph	<ul style="list-style-type: none"> Pricing and price basis [firm] - whilst not the sole factor for consideration, competitive pricing and overall level of unconditional discounts¹ will be critical B-BBEE status of company - Preference points will be awarded to a bidder for attaining the B-BBEE status level of contribution in accordance with the table indicated in Annexure

COMMERCIAL (80/20 in respect of price and preference claimed points)

Pricing and price basis [firm] whilst not the sole factor for consideration, competitive pricing and overall level of unconditional discounts² will be critical
B-BBEE status of company

Preference points will be awarded to a bidder for attaining the B-BBEE status level of contribution in accordance with the table below:

B-BBEE Status Level of Contributor	Number of points (80/20 system)
1	20
2	18
3	16
4	12
5	8
6	6
7	4
8	2
Non-compliant contributor	0

¹ Only unconditional discounts will be taken into account during evaluation. A discount which has been offered conditionally will, despite not being taken into account for evaluation purposes, be implemented when payment is effected.

² Only unconditional discounts will be taken into account during evaluation. A discount which has been offered conditionally will, despite not being taken into account for evaluation purposes, be implemented when payment is effected.



STATEMENT OF COMPLIANCE WITH THE REQUIREMENTS OF THE SCOPE OF WORK

I, _____ (insert name of Director or as per Authority Resolution from Board of Directors)

Of _____ (insert name of Company)

Hereby acknowledges having read, understood and agree to the requirements of the scope of work described in this tender document and is fully compliant.

Signed this _____ on _____ day _____ at _____

Signature _____

"PREVIEW COPY ONLY"



TRANSNET

freight rail

A Division of Transnet Limited

INFRASTRUCTURE TELECOMS

STANDARD

**TECHNICAL SPECIFICATION AND METHODS OF
MEASUREMENT FOR ANGLE MODULATED RADIO
EQUIPMENT**

Author: Senior Engineering Technician
Quality Assurance, National
Test Centre

C J Muller

Approved: Principal Engineer
Transmission Engineering

M L Nuttall
PP
MUMBULO
MMBENOWA

Date:

21 May 2014

Circulation Restricted To:

Transnet Freight Rail
Transnet and Relevant Third Parties

© This document as a whole is protected by copyright. The information herein is the sole property of Transnet Ltd. It may not be used, disclosed or reproduced in part or in whole in any manner whatsoever, except with the written permission of and in a manner permitted by the proprietors.

CONTENTS

I.	Distribution.....	3
II.	Document Change History	3
III.	Changes Since Last Revision	3
IV.	List of Abbreviations and Definitions	3
1.	Technical Specification.....	8
1.1	Radio Receiver	8
1.2	Radio Transmitter	9
1.3	Radio Base Station	11
1.4	Filters	12
1.5	Coaxial Cable	12
1.6	Antenna	12
1.7	Transmitting Power.....	13
1.8	Receiver Desensing	13
1.9	Audio Line Branching Unit.....	13
1.10	Power Supply Unit & Battery Charge.....	14
1.11	Trunking.....	14
1.12	Acoustical Measurements	15
1.13	Co-Channel Interference	15
2.	Methods of Measurement.....	17
2.1.	Applied Standard	17
2.2.	Radio Receiver	18
2.3.	Radio Transmitter	29
2.4.	High Site Equipment.....	38
2.4.1	Radio Base Station Response Time	38
2.4.2	Talk Through Signal	39
2.4.3	Filters.....	43
2.4.4	Coaxial Cable	46
2.4.5	Antenna	47
2.4.6	Receiver Desensing	48
2.4.7	Audio Line Branching Unit.....	48
2.4.8	Power Supply Unit & Battery Charger.....	53
2.5.	Trunking Functional Tests	56
2.6.	Acoustical Measurements	57
3.	Relevant Documentation	58

I Distribution

Once updated, a copy of the latest revision will be published in the document management system in use. An e-mail to this effect will be sent to the relevant personnel or heads of department.

II Document Change History

<u>ISSUE NO.</u>	<u>DATE ISSUED</u>	<u>ISSUED BY</u>	<u>HISTORY DESCRIPTION</u>
2.00	January 2004	Quality Assurance, Infrastructure	Revision
3.0	June 2006	QA	Convert to ISO Standard
3.1	June 2007	QA	Revision
4.0	July 2008	QA	Revision
5.0	February 2010	QA	New format & revision
6.0	August 2010	QA	New format & revision
6.1	November 2010	QA	Add measurement
6.2	August 2011	QA	Add information, definitions, supply standards & DC-DC Converter
7.0	January 2012	QA	Revision & add Trunking functional tests
8.0	May 2014	QA	Omit the difference between General and Shunt portables, revise the Loudspeaker sound pressure level & Transmitter microphone sensitivity.

III Changes Since Last Revision

<u>CLAUSES</u>	<u>DESCRIPTION</u>
IV	Add abbreviations
1.3.3.5	Change specification
1.11	Add trunking
2.4.2.3	Change graph
2.5	Add trunking functional tests
1.12	Omit the difference between General and Shunt portables, revise the Loudspeaker sound pressure level & Transmitter microphone sensitivity.

IV List of Abbreviations and Definitions

<u>ABBREVIATIONS</u>	<u>DESCRIPTION</u>
AC	Alternating Current
AF	Audio Frequency
BS	Base Station
CCITT	Consultative Committee for International Telephone and Telegraph (ITU-T)
CTCSS	Continuous Tone Coded Squelch System
dB	Decibel
dB(A)	Sound pressure A-weighted
dBc	Decibel relative to the carrier power
dBd	Decibel relative to a Dipole antenna
dBm	Decibel relative to 1 mW, impedance 50 Ω (power)
dBm	Decibel relative to 0.775 V _{pd} , impedance 600 Ω (audio frequency)
dB _{MUOP}	Decibel relative to the Maximum Useful Output Power
dB _{SOP}	Decibel relative to the Standard Output Power
DC	Direct Current
EMF	Electromotive Force
ERP	Effective Radiated Power
FFSK	Fast Frequency Shift Keying

FM	Frequency Modulation
GSM	Global System for Mobile communication
Hz	Hertz
ITU-T	International Telecommunication Union – Telecommunication Standardization Sector
kHz	Kilohertz
LBU	Line Branching Unit
LS	Loudspeaker
m	Metre
mA	Milliampere
MHz	Megahertz
mm	Millimetre
ms	Millisecond
mVp-p	Millivolt peak-to-peak
mW	Milliwatt
MUOP	Maximum Useful Output Power
pd	Potential Difference
PM	Phase Modulation
PSTN	Private Switching Telephone Network
RF	Radio Frequency
Rx	Radio receiver
SANS	South African National Standards
SINAD	Signal, Noise & Distortion to Noise & Distortion ratio
SOP	Standard Output Power
SPL	Sound Pressure Level
THD	Total Harmonic Distortion
TSC	Trunk Site Controller
Tx	Radio transmitter
V	Voltage
Vp-p	Voltage peak-to-peak
VSWR	Voltage Standing Wave Ratio
W	Wattage
WiFi	Wireless Fidelity
µV	Microvolt
%	Percentage

<u>DEFINITIONS</u>	<u>DESCRIPTION</u>
<u>GENERAL</u>	
Angle Modulation	A term used to encompass both frequency modulation and phase modulation.
Decibel	The decibel is 1/10 of a Bel. Decibel is the logarithm of the ratio between a measured quantity and an agreed reference level.
dBc	The absolute power in decibel with reference to the carrier power.
dBm	The absolute power in decibel with reference to 1 mW.
Land Mobile Radio Services	Radio communication from fixed radio stations to mobile radio stations carried in surface vehicles or portable radio stations, and between mobile and portable radio stations.

DEFINITIONS	DESCRIPTION
Portable Radio Station	A radio station designed to be carried by or on a person.
Mobile Radio Station	A radio station designed for installation in a surface vehicle and capable of operating while the vehicle is in motion and while it is stationary.
Fixed Radio Station	It is a fixed radio station installed in an office or control room, fitted with an external antenna.
Base Station	A radio station designed to be installed in a fixed location and performing the function of a repeater/enhancer.

RADIO RECEIVER	
Adjacent Channel Selectivity and Desensitization Ratio	A measure of the ability of a radio receiver to receive the modulated standard input signal in the presence of modulated signals that differ in frequency from the standard input signal frequency by the spacing of one channel.
Amplitude Characteristics	The relationship between the radio frequency input level of a specified modulated signal and the audio frequency level at a radio receiver output.
Attack Time	The time required to produce an audio output level of $-0.5 \text{ dB}_{\text{SOP}}$ after application of a RF signal level, 12 dB above usable sensitivity, modulated with standard test modulation.
Audio Frequency Response	The relationship between the modulation factor of a received signal and the audio output level of the demodulated signal at various audio frequencies.
Audio Frequency Total Harmonic Distortion	The change in harmonic content of an audio signal as a result of its passing through the audio frequency and radio frequency circuits of a radio.
Blocking or Desensitisation	A reduction in the wanted audio output power of a radio receiver, or a reduction in the SINAD ratio, owing to an unwanted signal on another frequency.
Co-channel Rejection Ratio	A measure of the capability of a radio receiver to receive a wanted modulated signal without exceeding a given degradation due to the presence of an unwanted modulated signal, both signals being at the nominal frequency of the receiver.
Conducted Spurious Radiation	It is radiation components at any frequency generated by a radio receiver and radiated by the radio's antenna.
Desensitisation	Is a condition where off-channel transmitting energy passes through the front-end of the radio receiver, causing a reduction in receiver gain.
High RF Signal Level Interference	A measure of the ability of a radio receiver to oppose high RF signal levels at frequencies other than the normal frequency of the receiver.
Intermodulation Spurious Response Attenuation/Rejection	The ability of a radio receiver to receive a modulated standard input signal, in the presence of two interfering signals of which the carrier frequencies are so separated from the standard input signal frequency and from each other that n'th order mixing of the two undesired signals can occur in the non-linear elements of the receiver, producing a third signal whose frequency is equal to that of the standard input signal frequency, or intermediate frequency.
Maximum Useful Output Power	The greatest average audio output power supplied to the rated load, which power does not exceed 10 % of the total harmonic distortion.
Modulation Acceptance Bandwidth	The selectivity characteristic of an angle modulated radio receiver that limits the maximum permissible modulation deviation of the radio frequency input signal that a receiver can accept, without degradation of the 12 dB SINAD ratio, when the radio frequency input signal is 6 dB greater than the usable sensitivity level.
Modulation Factor	The ratio of the maximum positive or negative peak variation of the modulating variable, to the maximum rated system-modulating variable, expressed as a

<u>DEFINITIONS</u>	<u>DESCRIPTION</u>
	percentage.
Signal, Noise & Distortion to Noise & Distortion Ratio	The ratio, expressed in decibels of the signal power, plus noise power, plus distortion power, to noise power plus distortion power produced at the output of a radio receiver resulting from a modulated signal input.
Signal to Hum and Noise Ratio	The ratio of residual receiver audio output power to standard output power.
Spurious Response Attenuation/Rejection	A measure of the ability of a radio receiver to discriminate between the standard input signal frequency and an undesired signal at any other frequency to which it is also responsive, excluding the two adjacent channels.
Squelch Closing Time	The period of time between the removal of the RF signal and the squelch closure.
Squelch Operating Threshold	The RF signal input level, modulated with standard test modulation, at which the squelch opens and closes.
Standard Output Power	An audio output level 3 dB below maximum useful output power used to define a reference level for test purposes.
Usable Sensitivity	The minimum radio frequency input signal level modulated with standard test modulation that will produce, at a radio receiver, a SINAD ratio of at least 12 dB and an audio output signal power of at least $-3 \text{ dB}_{\text{SOP}}$.
<u>RADIO TRANSMITTER</u>	
Adjacent Channel Power	The part of the total power output of a radio transmitter that, under defined conditions of modulation, falls within a specified bandwidth centred on the normal frequency of either of the adjacent channels.
Amplitude Modulation Hum & Noise Level	A measure of the unwanted amplitude modulation of a carrier resulting from hum and noise.
Angle Modulation Hum & Noise Ratio	The ratio of residual angle modulation to standard test modulation.
Audio Frequency Response	The relationship between the modulation factor of a transmitted signal and the input level of the modulating signal at various audio frequencies.
Audio Frequency Total Harmonic Distortion	The change in harmonic content of an audio signal as a result of its passing through the audio frequency and radio frequency circuits of a radio.
Carrier Attack Time	The time required, changing the state of a radio transmitter from standby to a state where the unmodulated carrier voltage level reaches a value 6 dB below the steady state.
Carrier Frequency Error	Is the difference between the measured unmodulated carrier frequency from the assigned frequency.
Carrier Power	The mean power available at the output terminal of a radio transmitter in the absence of modulation.
Conducted Spurious Emissions	Emissions at the antenna terminal of a radio transmitter on a frequency or frequencies that are outside the channel on which the transmitter is operating.
Extreme Transmitter Loads	Conditions under which the radio transmitter operates into an open circuit or short circuit.
Intermodulation Attenuation	The ability of a radio transmitter to attenuate signals generated in its non-linear elements by the presence of the carrier and a parasitic signal arriving at the transmitter through its antenna.
Microphone sensitivity	It is the amount of modulation that the radio transmitter produces when a specified audio signal level is present at the microphone.

<u>DEFINITIONS</u>	<u>DESCRIPTION</u>
Mismatch between Transmitter and Antenna System	A condition in which the impedance as presented to the radio transmitter by the transmission line and antenna is not the same as the designed system impedance.
Modulation Limiting (Tx deviation)	A measure of the ability of radio transmitter circuits to prevent a transmitter from producing modulation such that the modulation factor exceeds the maximum rated system modulation factor.

<u>TALK THROUGH SIGNAL</u>	
Modulation Factor Linearity	The relationship between the modulation factor of a received signal and the transmitted modulation factor.
<u>FILTERS</u>	
Duplexer/Combiner	Is a filter system providing RF isolation to allow the sharing of a single antenna for both transmission and reception.
Insertion Loss	It is the amount of loss to a signal passing through a filter at a designated frequency.
Receiver Isolation at Transmitter Frequencies	It is the ability of the duplexer/combiner to suppress the transmitter carrier power at the receiver port. It is also called the selectivity of the duplexer/combiner.
<u>ANTENNAS</u>	
Effective Radiated Power	It is the mean power radiated by the antenna in the direction of maximum radiation.
dBd	The power gain of an antenna in decibel with reference to a Dipole antenna.
<u>TRUNK CONTROL SIGNAL</u>	
Fast Frequency Shift Keying	Bit 0 = 1.8 kHz Bit 1 = 1.2 kHz

<u>AUDIO LINE BRANCHING UNIT</u>	
Common-mode Rejection Ratio	Is the ratio of the differential gain over the common-mode gain.
<u>POWER SUPPLY UNIT, DC-DC CONVERTER AND BATTERY CHARGER</u>	
Noise Voltage	Is irregular amplitude voltages superimposed on the output DC voltage line.
Output Voltage Regulation	It is the ability of a power supply device to keep the output voltage constant over a range of applied loads.
Ripple Voltage	Is AC voltage superimposed on the output DC voltage line.
Variac	A device that supply a variable AC voltage from 0 V to 260 V.
<u>ACOUSTIC</u>	
A-weighted	It is a network that weights an audio signal in a manner, which approximates to an inverted equal loudness contour (it approximates the human ear's response to sound).

<u>DEFINITIONS</u>	<u>DESCRIPTION</u>
Sound Pressure	It is the force (N) of sound on a surface area (m^2) perpendicular to the direction of the sound. SPL is express as N/m^2 or Pascal (Pa).

"PREVIEW COPY ONLY"

1. TECHNICAL SPECIFICATION

Where not specifically indicated, this specification only applies for open channel and Trunked radio systems.

1.1 Radio Receiver: 12.5 kHz channel spacing; operating frequency band 450 MHz to 470 MHz.

1.1.1 Normal condition (see clause 2.1.1)

Characteristics	Portable	Mobile & Fixed Radio Station	Base Station (Repeater)
1.1.1.1 Maximum Useful Audio Output Power	Maximum power not exceeding 10 % THD.		
1.1.1.2 Audio Frequency THD at Low Output Power Level 500 Hz & 1.0 kHz	≤ 5 %	≤ 2 %	≤ 2 %
1.1.1.3 Usable Sensitivity	≤ -115 dBm		
1.1.1.4 Squelch Operating Threshold	Open Close	- 115 dB minimum ≤ 3 dB lower than the opening threshold	See clause 1.3.1.1 ≤ 3 dB lower than the opening threshold
1.1.1.5 Attack Time	≤ 150 ms		
1.1.1.6 Squelch Closing Time	≤ 250 ms		
1.1.1.7 Modulation Acceptance Bandwidth	≥ 3.75 kHz		
1.1.1.8 Adjacent Channel Selectivity and Desensitization Ratio	≥ 60 dB	≥ 65 dB	≥ 70 dB
1.1.1.9 Spurious Response Attenuation/Rejection	≥ 70 dB	≥ 75 dB	≥ 75 dB
1.1.1.10 Intermodulation Spurious Response Attenuation/Rejection	≥ 65 dB	≥ 65 dB	≥ 70 dB
1.1.1.11 Co-channel Rejection Ratio	≤ 12 dB		
1.1.1.12 Blocking	≥ 84 dB		
1.1.1.13 Conducted Spurious Radiation	≤ - 57 dBm		
1.1.1.14 Audio Frequency Response (6 dB/octave)	300 to 900 Hz + 1 dB to - 3 dB 1.1 to 2.5 kHz + 1 dB to - 3 dB 3.0 kHz + 1 dB to - 4.5 dB		
1.1.1.15 Signal to Hum and Noise Ratio	Squelched Unsquelled	≥ 60 dB ≥ 39 dB	
1.1.1.16 Amplitude Characteristics	≤ 3 dB		

1.1.2 Extreme conditions (see clause 2.1.2)

Characteristics	Portable	Mobile & Fixed Radio Station	Base Station (Repeater)
1.1.2.1 Power Supply			
1.1.2.1.1 Usable Sensitivity variation	$\leq \pm 3$ dB		
1.1.2.1.2 Adjacent Channel Selectivity and Desensitisation Ratio	≥ 60 dB	≥ 65 dB	≥ 70 dB
1.1.2.2 Temperature			
1.1.2.2.1 Usable Sensitivity variation	$\leq \pm 3$ dB		
1.1.2.2.2 Adjacent Channel Selectivity and Desensitisation Ratio	≥ 60 dB	≥ 65 dB	≥ 70 dB
1.1.2.3 Selectivity at High RF Signal Level			
1.1.2.3.1 Input signal level	- 47 dBm to - 7 dBm		

1.2 **Radio Transmitter:** 12.5 kHz channel spacing; operating frequency band 450 MHz to 470 MHz.

1.2.1 Normal condition (see clause 2.1.1)

Characteristics	Portable	Mobile & Fixed Radio Station	Base Station (Repeater)
1.2.1.1 Carrier Power (conducted)	$\leq \pm 1$ dB from manufacturer's claim		
1.2.1.2 Conducted Spurious Emissions			
Operating	$\leq - 36$ dBm		
Standby	$\leq - 57$ dBm		
1.2.1.3 Carrier Frequency Error	≤ 1.5 kHz	≤ 1.5 kHz	≤ 1.0 kHz
1.2.1.4 Carrier Attack Time	≤ 100 ms		
1.2.1.5 Adjacent Channel Power	$\leq - 60$ dBc	$\leq - 70$ dBc	$\leq - 70$ dBc
	Or - 37 dBm maximum.		
1.2.1.6 Intermodulation Attenuation	n.a.	n.a.	≥ 40 dB
1.2.1.7 Modulation Limiting (Tx Deviation)			
Modulating freq.			
0.3 to 2.55 kHz	2.5 kHz maximum		
3 to 6 kHz	0.75 kHz maximum at 6 kHz		
6 to 12.5 kHz	- 14 dB/octave		
1.2.1.8 CTCSS Deviation	250 Hz		
1.2.1.9 Audio Frequency THD			
500 Hz	≤ 5 %	≤ 2 %	≤ 2 %
1.0 kHz			

	Characteristics	Portable	Mobile & Fixed Radio Station	Base Station (Repeater)
1.2.1.10	Audio Frequency Response (6 dB/octave) 300 to 900 Hz 1.1 to 2.5 kHz 3.0 kHz	+ 3 dB to – 1 dB + 3 dB to – 1 dB + 4.5 dB to – 1 dB		
1.2.1.11	Angle Modulation Hum & Noise Ratio	≥ 34 dB		
1.2.1.12	Amplitude Modulation Hum & Noise Level	≤ – 34 dB		

1.2.2 Extreme conditions (see clause 2.1.2)

	Characteristics	Portable	Mobile & Fixed Radio Station	Base Station (Repeater)
1.2.2.1	Power Supply			
1.2.2.1.1	Carrier Power Variation	≤ ± 2 dB		
1.2.2.1.2	Conducted Spurious Emissions Operating Standby	≤ – 36 dBm ≤ – 57 dBm		
1.2.2.1.3	Carrier Frequency Error	≤ 1.5 kHz	≤ 1.5 kHz	≤ 1.0 kHz
1.2.2.2	Temperature			
1.2.2.2.1	Carrier Power Variation	≤ ± 2 dB		
1.2.2.2.2	Conducted Spurious Emissions Operating Standby	≤ – 36 dBm ≤ – 57 dBm		
1.2.2.2.3	Carrier Frequency Error	≤ 1.5 kHz	≤ 1.5 kHz	≤ 1.0 kHz
1.2.2.3	Antenna Terminal Loads			
1.2.2.3.1	Short Circuit and Open Circuit Carrier Power Variation	≤ ± 1 dB		

1.3 **Radio Base Station (Repeater):** 12.5 kHz channel spacing; operating frequency band 450 MHz to 470 MHz.

The receiver and transmitter specifications are referred to in clauses 1.1 and 1.2 respectively.

1.3.1 Receiver

Characteristics	Base Station (Repeater)
1.3.1.1 Squelch operating threshold calculation	– 115 dBm minus coaxial cable loss minus duplexer loss plus antenna gain. ≤ 3 dB lower than the opening threshold
Open	
Close	

1.3.2 Receiver and transmitter

Characteristics	Base Station (Repeater)
1.3.2.1 Response time	≤ 300 ms

1.3.3 Talk Through Signal

Characteristics	Base Station (Repeater)
1.3.3.1 Audio input and output terminals	600 Ω balanced ≤ – 25 dB
1.3.3.1.1 Impedance	
1.3.3.1.2 Return Loss	
1.3.3.2 Audio Levels	– 10 dBm ± 0.5 dBm – 4 dBm ± 0.7 dBm
1.3.3.2.1 RTO & Trunking (local & remote site)	
1.3.3.2.2 Old Trunking Teletalk system	
1.3.3.3 Audio Frequency Response (With de-emphasis and pre-emphasis)	± 3.0 dB ± 3.0 dB
Modulating frequency	
300 to 900 Hz	
1.3.3.4 Audio Frequency Response (Without de-emphasis and pre-emphasis)	± 2.0 dB ± 2.0 dB
Modulating frequency	
300 to 900 Hz	
1.3.3.5 Modulation Factor Linearity	0.5 kHz ± 100 Hz 1.0 kHz ± 100 Hz 1.5 kHz ± 100 Hz 2.0 kHz ± 100 Hz 2.5 kHz – 250 Hz (not to exceed 2.5 kHz)
Modulation	
0.5 kHz	
1.0 kHz	
1.5 kHz	
2.0 kHz	
2.5 kHz	
1.3.3.6 Audio Frequency THD	≤ 5 %

1.4 **Filters**

1.4.1 Duplexer (Radio Train Order)

Characteristics		Base Station (Repeater)
1.4.1.1	Insertion Loss (Tx & Rx)	≤ 1.2 dB
1.4.1.2	Rx Isolation at Tx Frequencies	≥ 65 dB (operating band) ≥ 80 dB (single channel)
1.4.1.3	Impedance Matching, 50 Ω (all ports)	VSWR $\leq 1.5:1$ Return Loss ≤ -14 dB
1.4.1.4	* Operating Frequency Band Receiver Transmitter	465.0500 MHz to 466.9875 MHz 455.0500 MHz to 456.9875 MHz

* Duplexer for link operation is channelized.

1.4.2 Combiner (Trunked)

Characteristics		Base Station (Repeater)
1.4.2.1	Insertion Loss - Receiver path	0 dB \pm 0.5 dB
1.4.2.2	Insertion Loss - Transmit path	≤ 10 dB
1.4.2.3	Rx Isolation at Tx Frequencies	≥ 85 dB
1.4.2.4	Isolation between Rx ports	≥ 20 dB
1.4.2.5	Isolation between Tx ports	≥ 60 dB
1.4.2.6	Impedance Matching, 50 Ω (all ports)	VSWR $\leq 1.5:1$ Return Loss ≤ -14 dB
1.4.2.7	Operating Frequency Band Receiver Transmitter	465.0000 MHz to 466.6375 MHz 455.0000 MHz to 456.6375 MHz

1.5 **Coaxial Cable**

Characteristics		Mobile & Fixed Radio Station	Base Station (Repeater)
1.5.1	Impedance	50 Ω	
1.5.2	Impedance matching	VSWR $\leq 1.5:1$ Return Loss ≤ -14 dB	
1.5.3	Insertion loss	≤ 1 dB	≤ 5 dB

1.6 **Antenna**

Characteristics		Various
1.6.1	Impedance	50 Ω
1.6.2	Impedance matching VHF & UHF GSM & WiFi	VSWR $\leq 1.5:1$ Return Loss ≤ -14 dB VSWR $\leq 2.0:1$ Return Loss ≤ -9.54 dB

Characteristics	Various
-----------------	---------

1.6.3	* Antenna gain Mobile Fixed station Radio link: Point to point Point to multipoint Base station	0 dBd ≤ 12 dBd 9 dBd minimum Not specified ≤ 12 dBd
1.6.4	# Antenna vertical separation	≥ 4 λ
1.6.5	* Antenna height above ground level Mobile & Fixed station Radio link: Point to point Point to multipoint Base station	10 m maximum 20 m maximum 20 m maximum 20 m maximum

Based on 20 W ERP and antennae having a Dipole as a live element. Distance measured from centre to centre of dipoles.

* Licence conditions

1.7 Transmitting Power

	Characteristics	Various
1.7.1	* Conducted power at transmitter terminal Radio link: Point to point Point to multipoint	1 W maximum 1 W maximum
1.7.2	* Effective Radiated Power (ERP) Mobile & Fixed station Radio link: Point to point Point to multipoint Base station	20 W maximum 8.2 W maximum 8.2 W maximum 20 W maximum

* Licence conditions

1.8 Receiver Desensitng

	Characteristics	Various
1.8.1	Desensitng	≤ 1 dB
1.8.2	Desensitng at high receiving signal level (radio links only) ≥ - 100 dBm	≤ 20 dB

1.9 Audio Line Branching Unit

	Characteristics	Base Station (Repeater)
1.9.1	Audio input and output terminals Impedance Return Loss	600 Ω balanced ≤ - 25 dB
1.9.2	Input and output audio signal level	- 10 dBm ± 0.5 dB
1.9.3	Audio frequency response 300 Hz to 3 kHz	± 0.5 dB
1.9.4	Audio total harmonic distortion (THD)	≤ 0.5 %
1.9.5	Audio signal to hum and noise ratio	≥ 70 dB
1.9.6	Channel cross talk	≥ 60 dB
1.9.7	Common-mode rejection ratio	≥ 60 dB at 1 kHz
1.9.8	E-signal	Up to 50 V DC, 10 mA Opto coupler

	Characteristics	Base Station (Repeater)
1.9.9	M-signal	Bi-directional polarity Up to 50 V DC, 10 mA Voltage free contact

1.10 Power Supply Unit, DC-DC Converter and Battery Charger

	Characteristics	Various
1.10.1	Operating conditions Temperature range Relative humidity	- 10 °C to 60 °C Up to 85 %
1.10.2	Input power AC Voltage Frequency DC Voltage	220 V AC \pm 10 % 50 Hz \pm 2 % Nominal \pm 10 %
1.10.3	Output voltage regulation (Intermittent & continuous)	13.8 V \pm 5 % (12 V system) 27.6 V \pm 5 % (24 V system) 55.2 V \pm 5 % (48 V system)
1.10.4	Efficiency	\geq 70 %
1.10.5	Output voltage ripple & noise	\leq 200 mVp-p (12 V system) \leq 400 mVp-p (24 V system) \leq 800 mVp-p (48 V system)
1.10.6	Radiation of spurious frequencies	\leq - 119 dBm in radio operating band
1.10.7	Desensing of receiver	\leq 1 dB
1.10.8	Load shedding (when required)	Shed 11.0 V (12 V system) 22.0 V (24 V system) 44.0 V (48 V system) Restore 13.0 V (12 V system) 26.0 V (24 V system) 52.0 V (48 V system)

1.11 Trunking

1.11.1 Functional Tests

	Characteristics	Various
1.11.1.1	Registration	Register on instrument Register on trunk system
1.11.1.2	Local call to radio with the same prefix number	Establish call to instrument Establish call through the trunk system
1.11.1.3	Local call to radio with an interprefix number	Establish call to instrument Establish call through the trunk system
1.11.1.4	Local call to radio with the same prefix number using short form dialling	Establish call to instrument Establish call through the trunk system
1.11.1.5	Intersite call to radio with the same prefix number	Establish call through the trunk system
1.11.1.6	Intersite call to radio with an interprefix number	Establish call through the trunk system
1.11.1.7	Intersite call to radio with the same prefix number using short form dialling	Establish call through the trunk system

1.11.1.8	PSTN call	Establish call to instrument Establish call through the trunk system
1.11.1.9	Call the radio under test	Establish call from instrument Establish call through the trunk system
1.11.1.10	Handoff	Reregister on new control channel with Instrument Reregister on new control channel on the trunk system

1.11.2 Control Signal - Trunk Site Controller

	Characteristics	Base Station (Repeater)
1.11.2.1	FFSK level from TSC	1 Vp-p \pm 0.2 Vp-p
1.11.2.2	FFSK frequency from TSC	1.2 kHz \pm 100 Hz 1.8 kHz \pm 100 Hz
1.11.2.3	Tx deviation at FFSK level For channel dragging problem	1.5 kHz \pm 100 Hz 300 Hz \pm 100 Hz
1.11.2.4	FFSK level from Rx measured at TSC (Modulation 1.5 kHz) (Modulating frequency 1.2 kHz)	1 Vp-p \pm 0.2 Vp-p

1.12 Acoustical measurements

	Characteristics	Portable
1.12.1	Receiver	
	Loudspeaker sound pressure level	\geq 84 dB(A) at 300 mm
1.12.2	Transmitter	
	Transmitter deviation	Between 300 and 500 Hz from a SPL of 80 dB(A) at the microphone

1.13 Co-channel Interference

	Characteristics	Various
1.13.1	Speech	
	Level difference between signals	\geq 15 dB
1.13.2	Data (FFSK)	
	Level difference between signals	\geq 20 dB

2. METHODS OF MEASUREMENT

Applied Standard

- 2.1 Normal condition
- | | | |
|------------------------------|---|----------------|
| Temperature | : | 23 °C ± 3 °C |
| Relative Humidity | : | 45 to 85 % |
| Lead acid battery | : | 2.3 V per cell |
| Lithium-ion battery | : | 3.6 V per cell |
| Nickel cadmium | : | 1.2 V per cell |
| Nickel Metal Hydrate battery | : | 1.2 V per cell |
| Mains | : | 220 V AC 50 Hz |
- 2.2 Extreme conditions
- | | | |
|------------------------------|---|--|
| Temperature | : | - 10 °C and 60 °C |
| Relative humidity | : | 45 to 95 % |
| Lead acid battery | : | 1.8 V minimum & 2.6 V maximum per cell |
| Lithium-ion battery | : | 3.0 V minimum & 4.2 V maximum per cell |
| Nickel Cadmium battery | : | 1.0 V minimum & 1.5 V maximum per cell |
| Nickel Metal Hydrate battery | : | 1.0 V minimum & 1.5 V maximum per cell |
| Mains | : | 220 V AC ± 10 % 50 Hz ± 2 % |
- Power Supply Systems
- | | | | | |
|-------------|---|----------------|----------------|----------------|
| 12 V system | : | Minimum 11.0 V | Nominal 13.8 V | Maximum 15.6 V |
| 24 V system | : | Minimum 22.0 V | Nominal 27.6 V | Maximum 31.2 V |
| 48 V system | : | Minimum 44.0 V | Nominal 55.2 V | Maximum 62.4 V |
- 2.3 Warm up time
As specified by the manufacturer.
- 2.4 Temperature stabilising period
One hour minimum.
- 2.5 Power source tolerance
≤ ± 3 %.
- 2.6 Standard RF Test Signal
- 2.6.1 Standard test modulation
- | | | |
|----------------------|---|---|
| Modulation frequency | : | 1.0 kHz. |
| Modulation | : | 1.5 kHz (60 % of maximum rated system deviation). |
- 2.6.2 Standard RF Signal Input Level
- 6 dBm (223.6 μV_{pd} or 447.2 μV_{EMF}).
- 2.7 Audio Output Level
SOP - 3 dB_{MUOP}.

2.2 Radio Receiver

2.2.1 Maximum Useful Output Power

Connect the equipment as shown below.

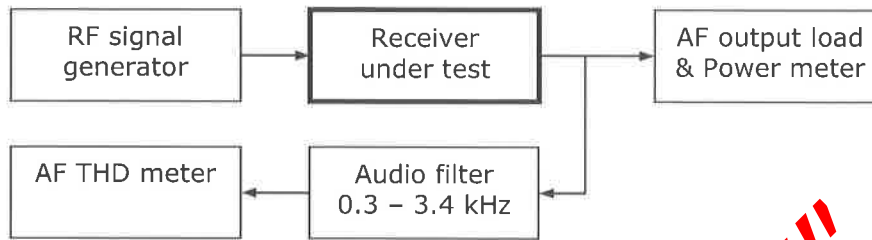

2.2.1.1 Inject a standard RF test signal from the RF signal generator.

2.2.1.2 Adjust the volume control of the radio until the THD is 10 % or the volume control reaches its maximum travel, whichever occurs first.

2.2.1.3 Measure the audio output power (MUOP).

Note: The impedance of the AF output load must be the same value as the load (loudspeaker) with which the receiver normally operates.

2.2.2 Audio frequency total harmonic distortion

Connect the equipment as shown below.

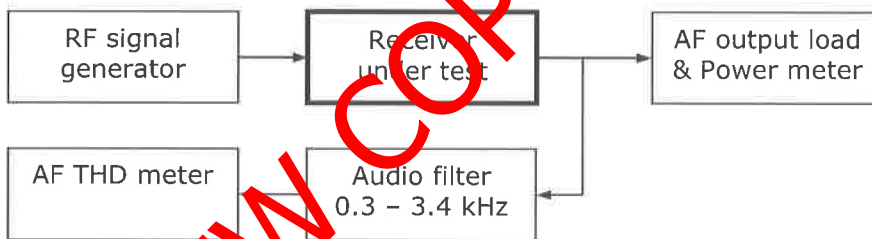

2.2.2.1 Standard measurement

2.2.2.1.1 Test 1.

2.2.2.1.1.1 Inject a standard RF test signal from the RF signal generator into the receiver.

2.2.2.1.1.2 Adjust the volume control of the radio to obtain SOP.

2.2.2.1.1.3 Measure the THD.

2.2.2.1.2 Test 2.

2.2.2.1.2.1 Change the modulating frequency to 500 Hz using the same modulation factor as in test 1, except that in the case of PM receivers, the modulation factor should be reduced by 50 %.

2.2.2.1.2.2 Repeat the procedure given in test 1.

2.2.2.1.2.3 Measure the THD.

2.2.2.2 600 Ω balanced line

Where a 600 Ω balanced line is provided, the THD must be measured on this line.

2.2.2.2.1 Inject a standard RF test signal from the RF signal generator into the receiver.

2.2.2.2.2 Load the line with a 600 Ω resistive load or equivalent impedance, provided by the measuring instrument.

2.2.2.2.3 Adjust the audio signal level to measure -10 dBm on the line.

2.2.2.2.4 Measure the THD.

2.2.2.2.5 Repeat the THD measurement when applying test 2.

2.2.3 Usable sensitivity

Connect the equipment as shown below.

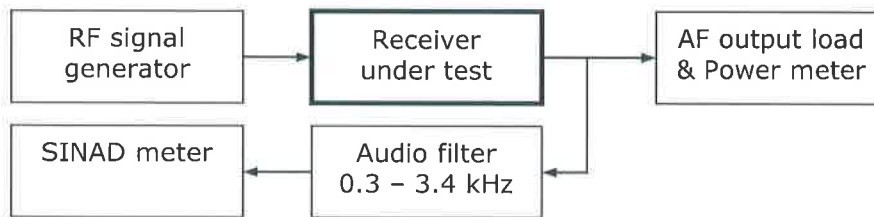

- 2.2.3.1 Adjust the RF signal generator to produce a standard RF input signal level.
- 2.2.3.2 Adjust the volume control of the radio to obtain SOP.
- 2.2.3.3 Reduce the RF signal level until the SINAD ratio is 12 dB.
- 2.2.3.4 Without readjustment of the volume control check whether the audio output level is less than $-3 \text{ dB}_{\text{SOP}}$.
- 2.2.3.5 If the audio output is less than $-3 \text{ dB}_{\text{SOP}}$, increase the RF signal level until $-3 \text{ dB}_{\text{SOP}}$ is obtained.
- 2.2.3.6 Take the RF signal output level from the signal generator at this setting as the usable sensitivity.
- 2.2.3.7 The measurement shall be made under the extreme test conditions as well. Under the extreme test conditions, the receiver audio output power shall be within $\pm 3 \text{ dB}$ of the value obtained under normal test condition.

Note: The impedance of the AF output load must be the same value as the load (loudspeaker) with which the receiver normally operates.

2.2.4 Squelch operating threshold

Connect the equipment as shown below.



- 2.2.4.1 Apply a standard RF test signal to the receiver under test and adjust the volume control of the radio to obtain SOP.
- 2.2.4.2 Reduce the RF signal level **slowly** until the squelch closes and record this RF signal level as the squelch closing level in dBm.
- 2.2.4.3 Increase the RF signal level **slowly** until the squelch opens and record this RF signal level as the squelch opening level in dBm.

2.2.5 Attack time

Connect the equipment as shown below.

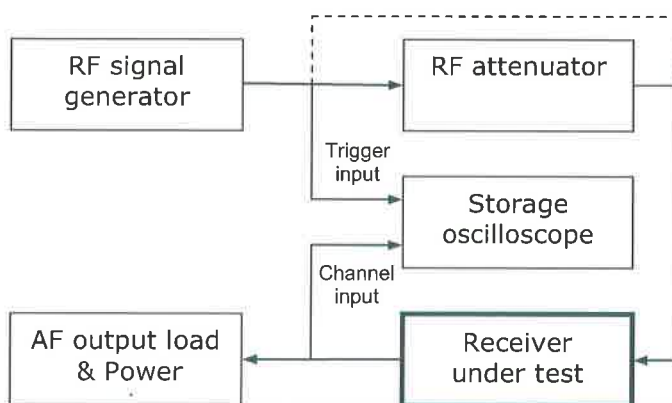

- 2.2.5.1 Apply a standard RF test signal to the receiver under test.

- 2.2.5.2 Adjust the volume control of the radio to obtain SOP.
- 2.2.5.3 Determine the usable sensitivity as described in clause 2.2.3.
- 2.2.5.4 Adjust the squelch to open at a RF signal level of -115 dBm, measured at the antenna terminal.
- 2.2.5.5 Set the RF signal level from the signal generator to 0 dBm.
- 2.2.5.6 Set the value of the RF attenuator to decrease the signal level to 12 dB above the usable sensitivity level, measured at the antenna terminal and switch the output of the signal generator off.
- 2.2.5.7 Set the storage oscilloscope to single sweep operation.
- 2.2.5.8 Switch the RF output on and measure the time required for the audio output to reach -0.5 dB_{SOP}.
- 2.2.5.9 Repeat the measurement three times and take the average of the three measurements as the receiver attack time.

2.2.6 Squelch Closing Time

Connect the equipment as shown below.

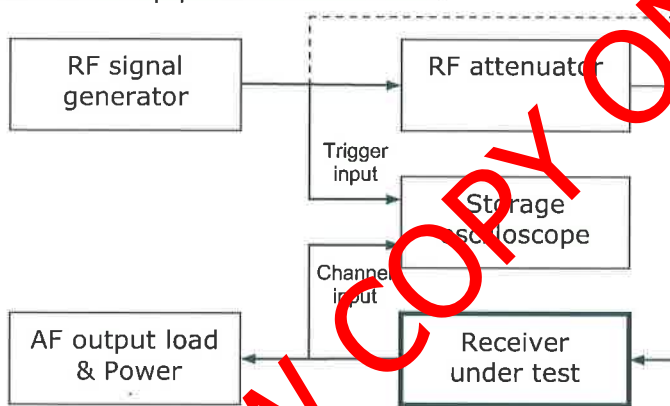

- 2.2.6.1 Apply a standard RF test signal to the receiver under test.
- 2.2.6.2 Adjust the volume control of the radio to obtain SOP.
- 2.2.6.3 Determine the usable sensitivity as described in clause 2.2.3.
- 2.2.6.4 Adjust the squelch to open at a RF signal level of -115 dBm, measured at the antenna terminal.
- 2.2.6.5 Set the RF signal level from the signal generator to 0 dBm.
- 2.2.6.6 Set the value of the RF attenuator to decrease the signal level to 12 dB above the usable sensitivity level, measured at the antenna terminal.
- 2.2.6.7 Set the storage oscilloscope to single sweep operation.
- 2.2.6.8 Switch the output of the signal generator off and measure the time required for the audio output to be reduced by 10 dB from the SOP value.
- 2.2.6.9 Repeat the measurement three times and take the average of the three measurements as the squelch closing time.

2.2.7 Modulation acceptance bandwidth

Connect the equipment as shown below.

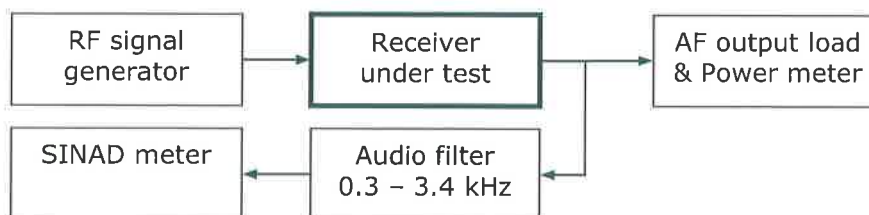

- 2.2.7.1 Apply a standard RF test signal to the receiver under test.
- 2.2.7.2 Adjust the receiver volume control to obtain SOP.

- 2.2.7.3 Reduce the RF signal level until the SINAD ratio is 12 dB.
- 2.2.7.4 Increase the RF signal level by 6 dB.
- 2.2.7.5 Increase the modulation factor until the SINAD ratio is again 12 dB.
- 2.2.7.6 Record this value of the modulation factor as the modulation acceptance bandwidth.

2.2.8 Adjacent channel selectivity and desensitization ratio

Connect the equipment as shown below.

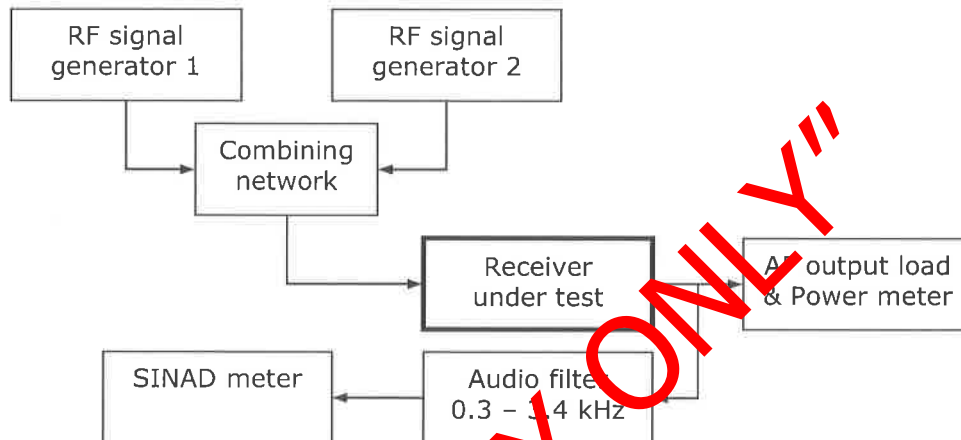

- 2.2.8.1 Switch the RF signal output of signal generator 2 off.
- 2.2.8.2 RF signal generator 1:
 - 2.2.8.2.1 Apply a standard RF test signal to the receiver under test.
 - 2.2.8.2.2 Adjust the volume control of the radio to obtain SOP.
 - 2.2.8.2.3 Reduce the RF signal until the SINAD ratio is 12 dB (wanted signal).
 - 2.2.8.2.4 Note this RF signal level.
- 2.2.8.3 RF signal generator 2:
 - 2.2.8.3.1 Switch the RF signal output on (unwanted signal).
 - 2.2.8.3.2 Modulate the RF signal with 400 Hz at the standard modulation factor.
 - 2.2.8.3.3 Set the frequency (unwanted signal) to a frequency one-channel width above the assigned frequency (wanted signal).
 - 2.2.8.3.4 Adjust the RF signal level such that the SINAD ratio is degraded to 6 dB.
 - 2.2.8.3.5 Note this RF signal level.
 - 2.2.8.3.6 Repeat for the unwanted signal set to a frequency one-channel width below the assigned frequency.
- 2.2.8.4 Calculate the difference between the unwanted and wanted signal levels in dB, as the adjacent channel selectivity and desensitization ratio.
- 2.2.8.5 Take the worst case of the two measurements as the result.
- 2.2.8.6 The measurements shall be made under the extreme test conditions as well.

2.2.9 Spurious response attenuation/rejection

Connect the equipment as shown below.

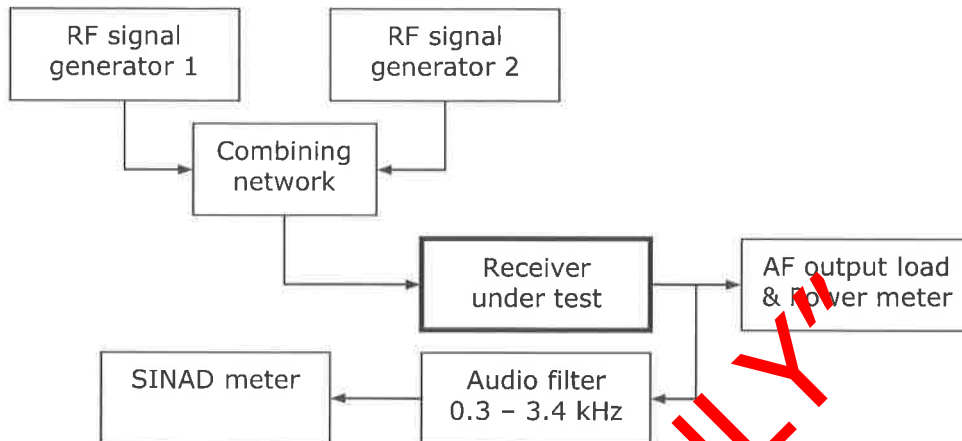

2.2.9.1 Switch the RF signal output of signal generator 2 on.

2.2.9.2 RF signal generator 1:

2.2.9.2.1 Adjust the RF signal generator to produce a standard RF test signal.

2.2.9.2.2 Adjust the volume control of the radio to obtain SOP.

2.2.9.2.3 Reduce the RF signal to the receiver until the SINAD ratio is 12 dB.

2.2.9.3 RF signal generator 2:

2.2.9.3.1 Switch the RF signal output on and adjust the signal level to 80 dB (portable) or 85 dB (mobile and base) higher than that of signal generator 1.

2.2.9.3.2 Modulate the RF signal with 400 Hz at standard modulation factor.

2.2.9.3.3 Slowly sweep the carrier frequency over the range 100 kHz to 1 GHz in 12.5 kHz steps (channels) excluding the assigned channel and the two adjacent channels.

2.2.9.3.4 When the receiver is responsive to a spurious signal, adjust the RF signal level until the SINAD ratio is 6 dB.

2.2.9.4 Note the frequency and the RF signal levels of the two signal generators and take the difference between the two levels expressed in dB as the measure of the spurious response attenuation at that frequency.

Note: Ensure that the measured response is not caused by spurious signals from the RF signal generators or Intermodulation products between the two signals.

2.2.10 Intermodulation spurious response attenuation/rejection

Connect the equipment as shown below.

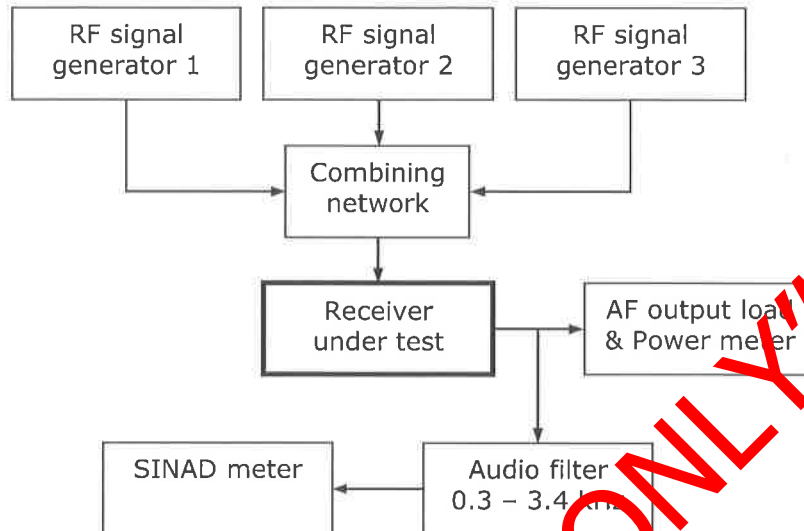

- 2.2.10.1 Switch the RF signal output of signal generators 2 & 3 off.
- 2.2.10.2 RF signal generator 1:
- 2.2.10.2.1 Adjust the RF signal generator to produce a standard RF test signal.
- 2.2.10.2.2 Adjust the volume control of the radio to obtain SOP.
- 2.2.10.2.3 Reduce the RF signal to the receiver until the SINAD ratio is 12 dB.
- A. 2.2.10.3 RF signal generator 2:
- 2.2.10.3.1 Adjust the unmodulated frequency of the RF signal generator to the second adjacent channel above the nominal carrier frequency.
- 2.2.10.4 RF signal generator 3:
- 2.2.10.4.1 Modulate the RF signal with 400 Hz at standard modulation factor.
- 2.2.10.4.2 Adjust the frequency of the RF signal generator to the fourth adjacent channel above the nominal carrier frequency.
- 2.2.10.5 Switch the RF signal output of signal generators 2 & 3 on.
- 2.2.10.6 Maintain the outputs of RF signal generators 2 & 3 at equal levels.
- 2.2.10.7 Adjust the RF signal levels to reduce the SINAD ratio to 6 dB.
- 2.2.10.8 Adjust the frequency of RF signal generator 3 slightly to produce the maximum interfering signal.
- 2.2.10.9 Note the difference in dB between the RF signal output level from RF signal generator 1 and the RF signal output level from RF signal generators 2 & 3.
- B. 2.2.10.10 Repeat these measurements with RF signal generators 2 & 3 adjusted to the fourth adjacent and eighth adjacent channels above the nominal carrier frequency.
- C. 2.2.10.11 The measurements described in A & B shall be repeated with RF signal generators 2 & 3 set to the appropriate channels below the nominal frequency of the receiver.
- 2.2.10.12 Record the worst ratio in dB as the measure of the intermodulation spurious response attenuation.

2.2.11 Co-channel rejection ratio

Connect the equipment as shown below.

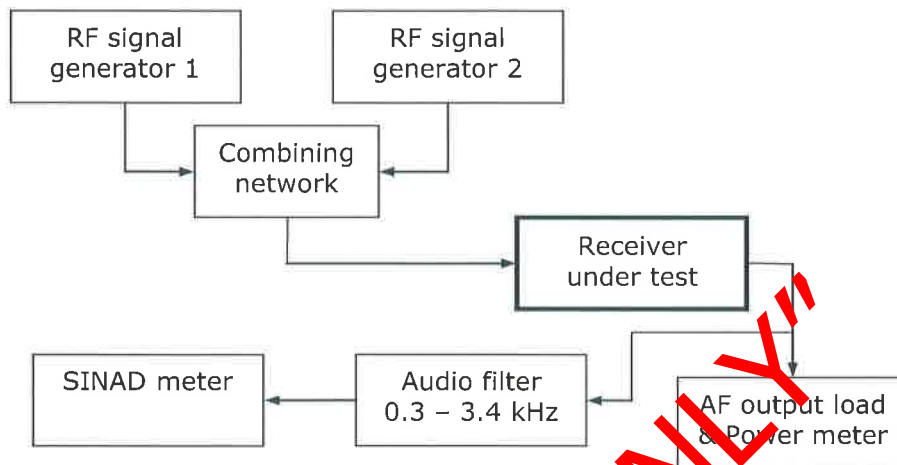

2.2.11.1 Switch the RF signal output of signal generator 2 off.

2.2.11.2 RF signal generator 1:

2.2.11.2.1 Adjust the RF signal generator to produce a standard RF test signal.

2.2.11.2.2 Adjust the volume control of the radio to obtain SOP.

2.2.11.2.3 Reduce the RF signal until the SINAD ratio is 12 dB (wanted signal).

2.2.11.3 RF signal generator 2:

2.2.11.3.1 Switch the RF signal output on (unwanted signal).

2.2.11.3.2 Set the frequency to the assigned receiver frequency.

2.2.11.3.3 Modulate the RF signal with 400 Hz at standard modulation factor.

2.2.11.3.4 Adjust the RF signal level such that the SINAD ratio is reduced to 6 dB.

2.2.11.4 Record the co-channel rejection ratio as the difference in dB, between the wanted and unwanted signal levels.

2.2.11.5 Repeat the measurement with signal generator 2 set to frequencies 1.5 kHz and 3.0 kHz above and below the assigned frequency.

2.2.11.6 The highest value of the five measurements shall be recorded as the co-channel rejection ratio.

2.2.12 Blocking or Desensitisation

Connect the equipment as shown below.

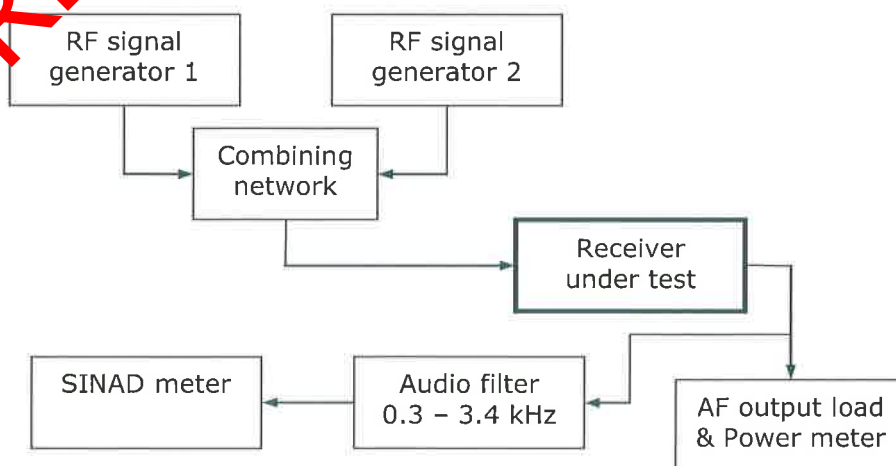

2.2.12.1 Switch the RF signal output of signal generator 2 off.

2.2.12.2 RF signal generator 1:

- 2.2.12.2.1 Adjust the RF signal generator to produce a standard RF test signal.
- 2.2.12.2.2 Adjust the volume control of the radio to obtain SOP.
- 2.2.12.2.3 Reduce the RF signal until the SINAD ratio is 12 dB (wanted signal).
- 2.2.12.3 RF signal generator 2:
- 2.2.12.3.1 Switch the unmodulated RF signal output on (unwanted signal).
- 2.2.12.3.2 Set the RF signal to a level 84 dB higher than signal generator 1.
- 2.2.12.3.3 Vary the frequency from 1 MHz to 10 MHz on either side of the assigned carrier frequency.
- 2.2.12.4 Monitor the variation in the audio output level and the SINAD ratio.
- 2.2.12.5 Record the difference in dB between the signal output levels from the two RF signal generators at which the audio output power decreased with 3 dB or the SINAD ratio decreases to 6 dB, whichever occurs first.

Note: Ensure that the measured response is not caused by spurious signals from the RF signal generators.

2.2.13 Conducted Spurious radiation

Connect the equipment as shown below.

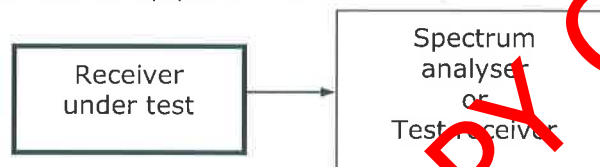

- 2.2.13.1 Switch the receiver on.
- 2.2.13.2 The receiver must be in standby mode.
- 2.2.13.3 Slowly sweep the measuring instrument over the range 9 kHz to 4 GHz.
- 2.2.13.4 Record the frequencies and measure the absolute levels of the conducted spurious radiation.

2.2.14 Audio frequency response

Connect the equipment as shown below.

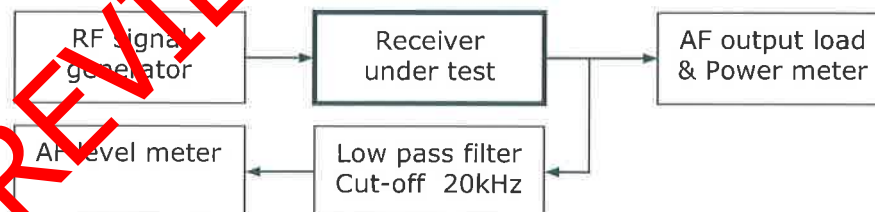

- 2.2.14.1 Standard measurement
- 2.2.14.1.1 Adjust the RF signal generator to produce a standard RF test signal and inject it into the receiver.
- 2.2.14.1.2 Adjust the volume control of the radio to obtain SOP.
- 2.2.14.1.3 Adjust the modulation of the RF signal generator to 20 % of the maximum system deviation.
- 2.2.14.1.4 While keeping the modulation factor constant vary the modulating frequency over the range 300 Hz to 3 kHz.
- 2.2.14.1.5 Record the variation of the audio output power over this range in dB with reference to the corresponding level at 1 kHz.
- 2.2.14.1 600 Ω balanced line
- Where a 600 Ω balanced line is provided, the audio frequency response must be measured on this line.
- 2.2.14.2.1 Inject a standard RF test signal from the RF signal generator into the receiver.
- 2.2.14.2.2 Load the line with a 600 Ω resistive load or equivalent impedance, provided by the measuring instrument.

- 2.2.14.2.3 Adjust the audio signal level to measure – 10 dBm on the line.
- 2.2.14.2.4 Proceed with clauses 2.2.14.1.3 and 2.2.14.1.5.

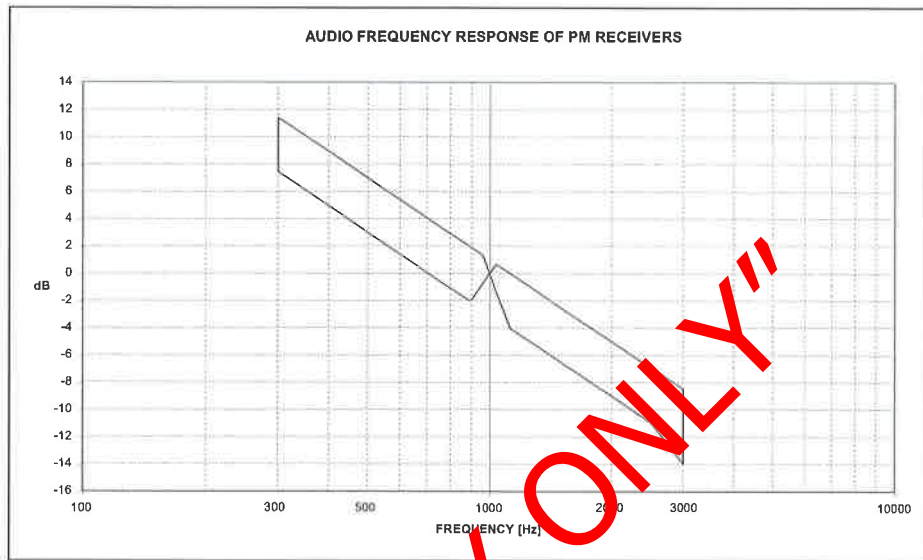

6dB/octave slope

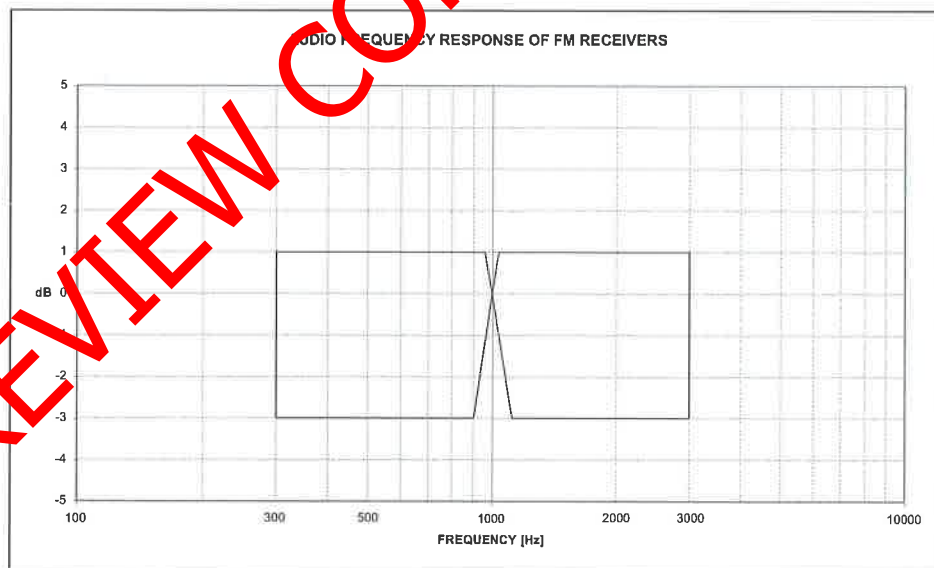

"PREVIEW COPY ONLY"

2.2.15 **Signal to hum and noise ratio**

Connect the equipment as shown below.

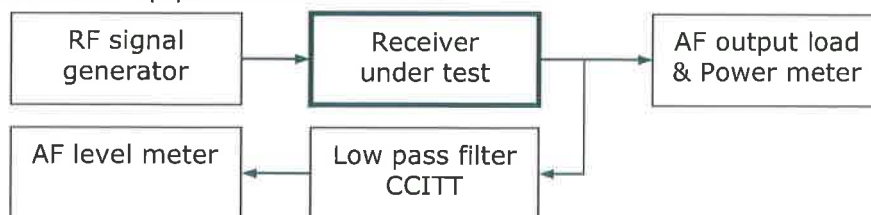

- 2.2.15.1 Select the CCITT filter (low pass filter).
- 2.2.15.2 Adjust the RF signal generator to produce a standard RF test signal.
- 2.2.15.3 Adjust the volume control of the radio to obtain SOP.

- 2.2.15.4 Adjust the squelch to its minimum (unsquelched).
- 2.2.15.5 Remove the modulation and measure the audio output power.
- 2.2.15.6 Adjust the squelch to its maximum (squelched).
- 2.2.15.7 If the receiver remains unsquelched remove the RF signal.
- 2.2.15.8 Measure the audio output power.
- 2.2.15.9 Record the ratio in dB between the audio output powers without modulation, and the SOP level as the signal to hum and noise ratio.

2.2.16 **Amplitude characteristics**

Connect the equipment as shown below.

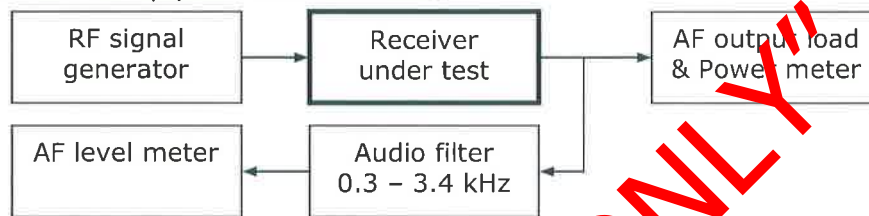

- 2.2.16.1 Adjust the RF signal generator to produce a standard RF test signal.
- 2.2.16.2 Increase the RF output signal level to -13 dBm.
- 2.2.16.3 Adjust the volume control of the radio to obtain SOP.
- 2.2.16.4 Decrease the RF signal output level from -13 dBm to -107 dBm and measure the change in the audio output level in dB.

2.2.17 **High RF signal level interference**

Connect the equipment as shown below.

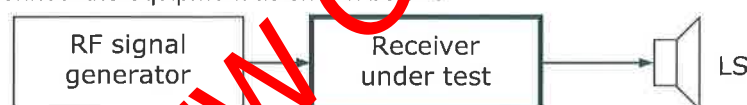

- 2.2.17.1 Set the radio to operate on the lowest channel.
- 2.2.17.2 Adjust the RF signal generator to produce a standard RF test signal.
- 2.2.17.3 Adjust the squelch to open at a RF signal level of -115 dBm.
- 2.2.17.4 Increase the RF signal level to -7 dBm.
- 2.2.17.5 Scan the frequencies of 132 channels above the receiving channel, excluding the assigned channel and the adjacent channels.
- 2.2.17.6 Record the channel and the RF signal level, at which the squelch opens in the window of -47 dBm to -7 dBm.
- 2.2.17.7 Set the radio to operate on the highest channel.
- 2.2.17.8 Scan the frequencies of 132 channels below the receiving channel, excluding the assigned channel and the adjacent channels.
- 2.2.17.9 Record the channel and the RF signal level, at which the squelch opens in the window of -47 dBm to -7 dBm.

Note: Where the interfering channels correspond with the intermodulation free channel groups, interference could occur.

Intermodulation free channel groups**High site channels**Duplex, 5th order, 132 channels

Group A	1	2	6	8	22	37	54	61	79	80	88	91	101	124	129
---------	---	---	---	---	----	----	----	----	----	----	----	----	-----	-----	-----

Duplex, 5th order, 132 channels

Group B	3	4	7	23	45	73	75	85	96	102	120	128
---------	---	---	---	----	----	----	----	----	----	-----	-----	-----

Duplex, 5th order, 132 channels

Group C	16	41	57	59	74	78	83	110	122	123	130
---------	----	----	----	----	----	----	----	-----	-----	-----	-----

Duplex, 5th order, first 52 channels

Group D	17	18	21	31	40	46	48
---------	----	----	----	----	----	----	----

Duplex, 5th order, first 52 channels

Group E	19	28	32	43	44	49	51
---------	----	----	----	----	----	----	----

Duplex, 5th order, first 52 channels

Group F	29	30	35	42	50	52
---------	----	----	----	----	----	----

Duplex, 5th order, first 52 channels

Group G	11	14	24	26
---------	----	----	----	----

Duplex, 5th order, first 52 channels

Group H	34	36	47
---------	----	----	----

Shunting channelsSimplex, 5th order, last 80 channels

Group A	53	56	60	71	97	99	109	118	126	131	132
Group B	55	58	62	63	72	84	112	125			
Group C	64	67	69	76	95	103	116	127			
Group D	68	77	82	91	107	113	114	117			
Group E	65	66	70	94	100	121					
Group F	81	87	89	92	104	108					

2.3 Radio Transmitter

2.3.1 Carrier power (conducted)

Connect the equipment as shown below.



2.3.1.1 Measure the carrier power in the absence of modulation.

2.3.1.2 The measurement shall be made under the extreme test conditions as well.

2.3.2 Conducted spurious emissions

Connect the equipment as shown below.

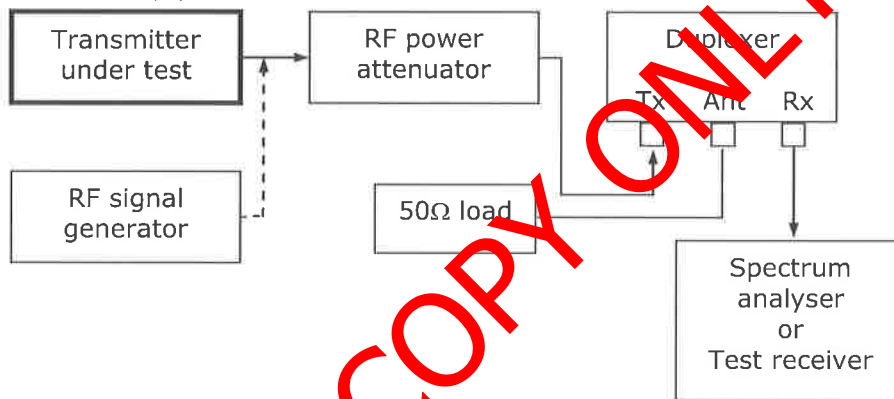

2.3.2.1 The duplexer must be tuned to the operating band. See specifications in clause 1.4.1.

2.3.2.2 The value of the RF attenuator (including the duplexer) must be such to limit the carrier level at the spectrum analyser/test receiver to approximately -60 dBm.

2.3.2.3 With the transmitter transmitting an unmodulated carrier, measure and record the frequencies and absolute levels of the conducted spurious up to the 5th harmonic.

2.3.2.4 Replace the transmitter with the RF signal generator.

2.3.2.5 Tune the RF signal generator to the recorded frequency and adjust the output level to obtain the recorded level on the spectrum analyser/test receiver.

2.3.2.6 Record the output level of the RF signal generator as the conducted spurious emission at that specific frequency.

2.3.2.7 Repeat 2.3.2.5 & 2.3.2.6 for all the other spurious emissions detected.

2.3.2.8 Remove the RF attenuator and duplexer and repeat the measurements when the transmitter is in the standby mode.

2.3.2.9 The measurements shall be made under the extreme test conditions as well.

2.3.1.10 With the above circuit the reverse channels can also be tested.

2.3.3 Carrier frequency error

Connect the equipment as shown below.

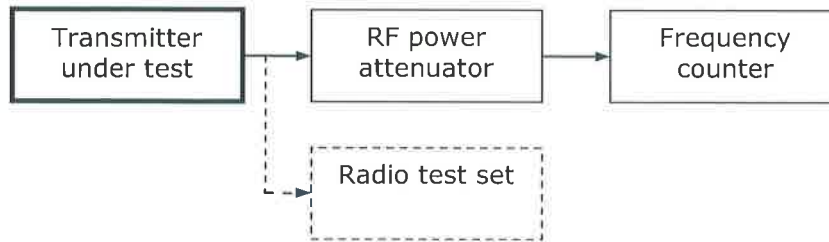

2.3.3.1 Measure the carrier frequency in the absence of modulation.

2.3.3.2 Repeat the measurement on each channel on which the transmitter is equipped to operate.

2.3.3.3 Calculate the carrier frequency error as the difference between the assigned frequency and the measured frequency. (Some test instruments can be set to measure the frequency error directly).

2.3.3.4 Record the worst case as the result.

2.3.3.5 The measurement shall be made under the extreme test conditions as well.

2.3.4 Carrier attack time

Connect the equipment as shown below.

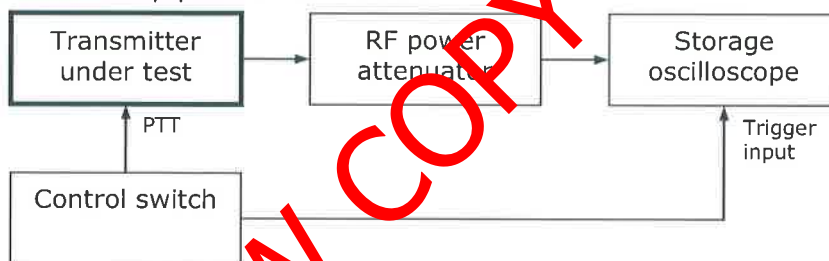

2.3.4.1 Set the storage oscilloscope to single sweep operation.

2.3.4.2 Operate the control switch and measure the time interval for the unmodulated carrier voltage level to reach a value 6 dB (50 %) below the steady state level.

2.3.5 Adjacent channel power

Connect the equipment as shown below.

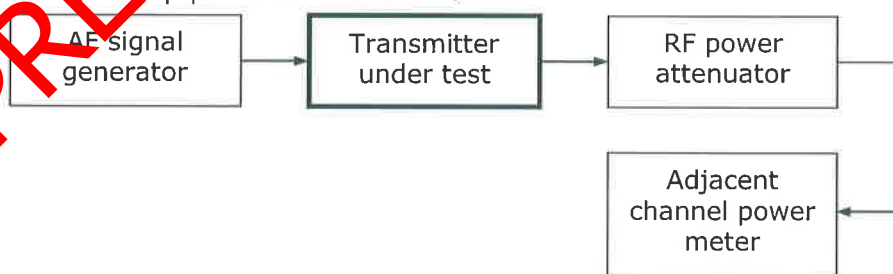

2.3.5.1 Ensure that the modulation limiting (Tx deviation) is set correctly (see clause 2.3.7).

2.3.5.2 Measure the unmodulated carrier power level.

2.3.5.3 Modulate the transmitter with a 1 250 Hz signal at a level 20 dB greater than that required to produce the standard test modulation factor.

2.3.5.4 Measure the mean power produced by the modulation, hum and noise of the transmitter in the adjacent channels.

2.3.5.5 Express the adjacent channel power in dB with reference to the measured carrier power.

2.3.5.6 Record the worst ratio as the measure of the adjacent channel power.

Or: When the measured level does not comply with the specification:

The adjacent channel power not to exceed a level of -37 dBm irrespective of the carrier power level.

2.3.6 **Intermodulation attenuation** (fixed radio stations only)

Method A: Connect the equipment as shown below.

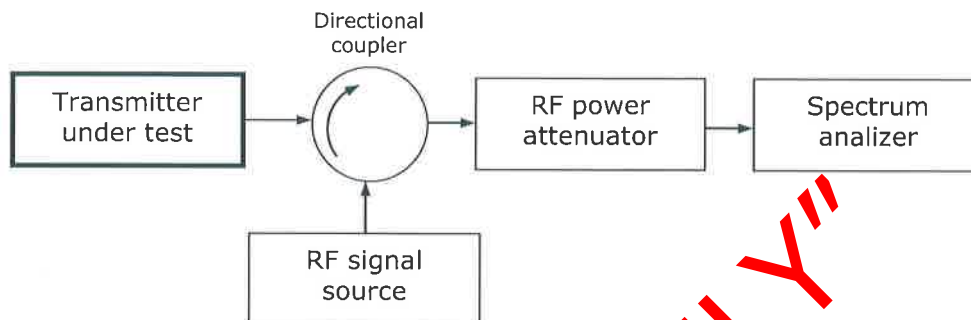

- 2.3.6.1 Set the unmodulated signal level from the RF signal source to give a level, measured at the transmitter output terminal, 30 dB below the output carrier level.
- 2.3.6.2 With the transmitter transmitting an unmodulated carrier, vary the frequency of the RF signal source between 50 kHz and 100 kHz, above and below the carrier frequency.
- 2.3.6.3 Measure the levels of the Intermodulation components.
- 2.3.6.4 The Intermodulation attenuation is expressed as the ratio of the carrier level to the level of the largest Intermodulation product (third order) observed.
- 2.3.6.5 Record the worst case as the result.

Note: Ensure that the measured response is not caused by spurious signals from the RF signal source.

Method B: Connect the equipment as shown below.

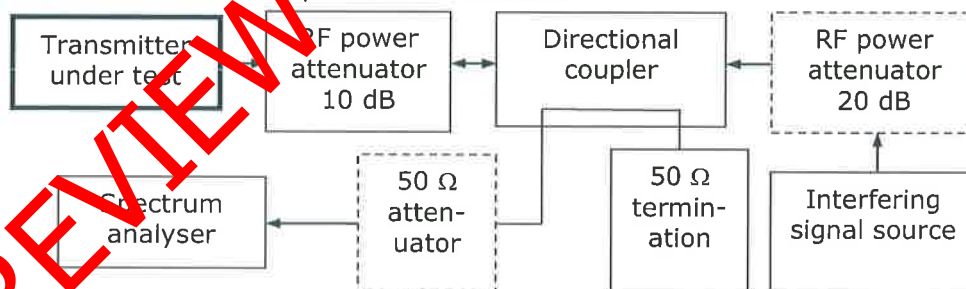

- 2.3.6.6 The coupling between the transmitter under test and the 10 dB RF power attenuator must be as short as possible to minimize mismatching.
- 2.3.6.7 The directional coupler must have an insertion loss of ≤ 1 dB, directivity of ≥ 20 dB and sufficient bandwidth.
- 2.3.6.8 The transmitter under test and the interfering signal source must have sufficient physical separation to prevent the measurement being influenced by direct radiation.
- 2.3.6.9 The RF signal level from the interfering signal source must have the same level as that of the transmitter. Alternatively, the RF signal level from the interfering signal source must be 20 dB lower than that of the transmitter – omit the 20 dB RF power attenuator.
- 2.3.6.10 The transmitter under test shall be unmodulated.
- 2.3.6.11 The spectrum analyser must be adjusted to give a maximum indication (amplitude) with a frequency scan of 500 kHz.
- 2.3.6.12 The interfering signal source must be unmodulated and the frequency must be varied between 50 kHz to 100 kHz above and below the frequency of the transmitter under test.

2.3.6.13 Measure the levels of the Intermodulation components on the spectrum analyser and determine the ratio of the carrier level to the level of the largest Intermodulation product (third order) observed, in dB.

2.3.6.14 Record the worst case as the result.

Note: Ensure that the measured response is not caused by spurious signals from the RF signal source.

2.3.7 **Modulation limiting** (Tx deviation)

Connect the equipment as shown below.

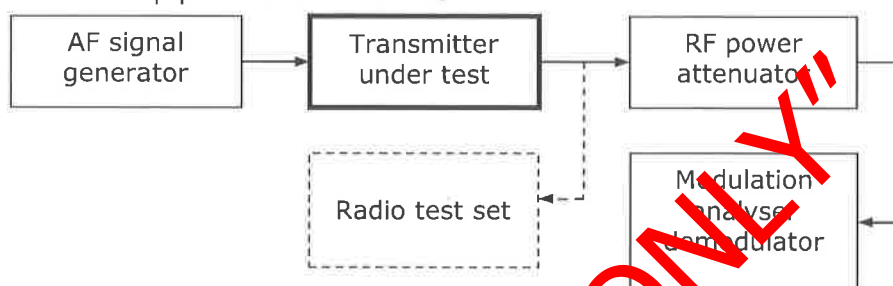

2.3.7.1 Ensure that the maximum deviation is set correctly and according to the manufacturer's procedure.

2.3.7.2 Apply electrically a 1 kHz audio test signal to the microphone input of the transmitter at a level sufficient to produce the standard test modulation factor.

(When an electrical input signal cannot be applied this may be replaced by an acoustical signal.)

2.3.7.3 Set the audio filter of the modulation analyser to Low Pass cut-off 15 kHz or 20 kHz.

2.3.7.4 Note the level of the audio test signal (reference).

2.3.7.5 Modulating frequency 0.3 kHz to 2.55 kHz:

2.3.7.5.1 Increase the audio test signal with 20 dB. Ensure that the measured deviation equals the maximum system deviation.

2.3.7.5.2 Without changing the audio input signal level vary the modulating frequency between 300 Hz and 2.55 kHz.

2.3.7.5.3 Record the largest positive or negative peak deviation obtained, as the modulation limit.

2.3.7.6 Modulating frequency 2.55 kHz to 6.0 kHz:

2.3.7.6.1 Decrease the audio test signal to obtain the standard test modulation factor (reference).

2.3.7.6.2 Without changing the audio input signal level vary the modulating frequency between 2.55 kHz and 6.0 kHz.

2.3.7.6.3 Record the largest positive or negative peak deviation obtained, as the modulation limit for the specific modulating frequency band.

Note: The deviation produced by the modulating frequencies between 2.55 kHz and 6.0 kHz must not exceed that of the deviation produced by the modulating frequency 2.55 kHz.

2.3.7.7 Modulating frequency 6.0 kHz to 12.5 kHz:

2.3.7.7.1 Obtain the standard test modulation factor (reference).

2.3.7.7.2 Without changing the audio input signal level vary the modulating frequency between 6.0 kHz and 12.5 kHz.

2.3.7.7.3 Record the decrease in the positive or negative peak deviation, as the modulation limit for the specific modulating frequency band.

Note: Care must be taken not to generate hum when the audio signal is connected electrically.

It must be ensured that the acoustical audio source has a flat response throughout the bandwidth.

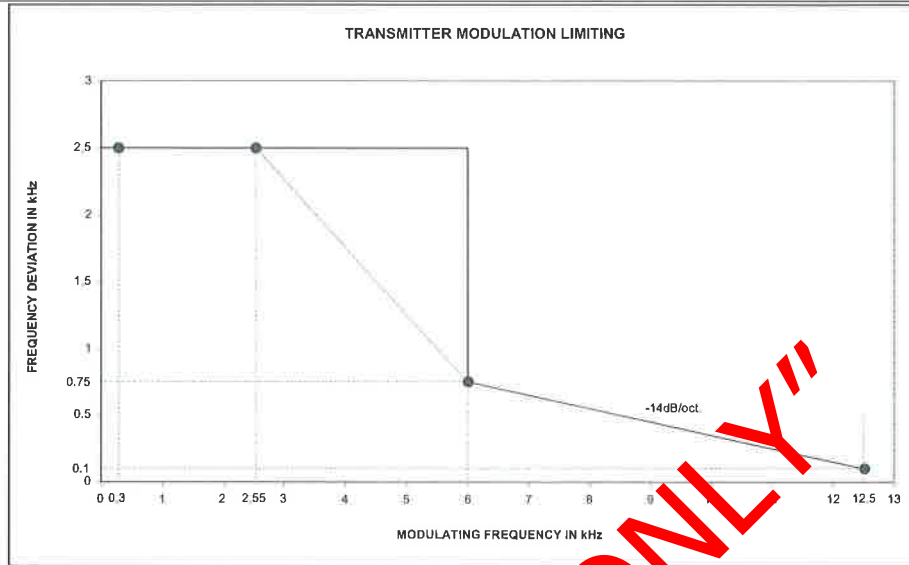

2.3.8 CTCSS deviation

Connect the equipment as shown below.

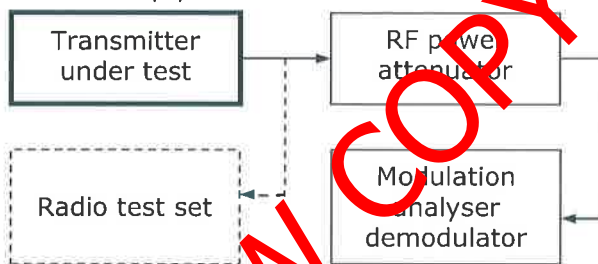

- 2.3.8.1 Select the CTCSS frequency and activate the function.
- 2.3.8.2 Set the audio filter of the modulation analyser to Low Pass cut-off 15 kHz or 20 kHz.
- 2.3.8.3 In the absence of an audio input signal (modulating signal) transmit a carrier.
- 2.3.8.4 Measure and record the deviation of the sub-audible tone.

2.3.9 Audio frequency total harmonic distortion (THD)

Connect the equipment as shown below.

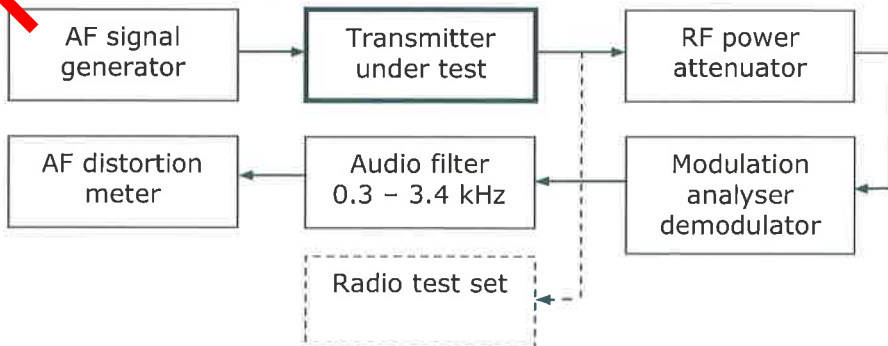

- 2.3.9.1 Standard measurement
 - 2.3.9.1.1 Apply electrically a 1 kHz audio test signal to the microphone input of the transmitter at a level sufficient to produce the standard test modulation factor.
 - 2.3.9.1.2 Record the distortion obtained.
 - 2.3.9.1.3 Adjust the audio signal generator frequency to 500 Hz.

2.3.9.1.4 Set the audio output signal at a level sufficient to produce the standard test modulation factor.

2.3.9.1.5 Record the distortion obtained.

Note: Care must be taken not to generate hum when the audio signal is connected electrically.

2.3.9.2 600 Ω balanced line input

Where a 600 Ω balanced line is provided, the THD must be measured on this line.

2.3.9.2.1 Load the line with a 600 Ω resistive load or equivalent impedance, provided by the test instrument.

2.3.9.2.2 Inject a 1 kHz audio test signal into the line at a level of -10 dBm.

2.3.9.2.3 Ensure that the transmitting signal deviation comply with the standard test modulation factor.

2.3.9.2.4 Measure and record the THD.

2.3.10 **Audio frequency response**

Connect the equipment as shown below.

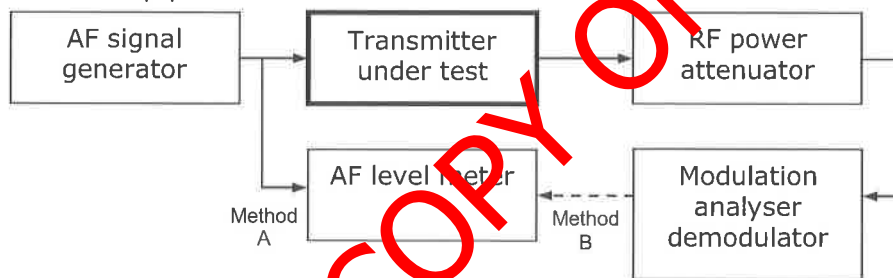

2.3.10.1 Standard measurement

Method A.

2.3.10.1.1 Apply electrically a 1 kHz audio test signal to the microphone input of the transmitter at a level sufficient to obtain 20 % of the maximum system deviation.

2.3.10.1.2 Select the low pass filter (cut-off 20 kHz) at the modulation analyser.

2.3.10.1.3 Vary the modulating frequency (audio signal) from 300 Hz to 3 kHz.

2.3.10.1.4 Adjust the modulating frequency level (audio signal) to maintain the modulation factor constant.

2.3.10.1.5 Record the variation in the audio output level of the AF signal generator in dB with reference to the corresponding level at 1 kHz.

Method B.

2.3.10.1.6 Apply electrically a 1 kHz audio test signal to the microphone input of the transmitter at a level sufficient to obtain 20 % of the maximum system deviation.

2.3.10.1.7 Select the low pass filter (cut-off 20 kHz) at the modulation analyser.

2.3.10.1.8 Keeping the audio signal level constant, vary the frequency from 300 Hz to 3 kHz.

2.3.10.1.9 Record the variation in the audio output level from the demodulator in dB with reference to the corresponding level at 1 kHz.

Note: The + and – signs must be inverted to be able to apply the graph.

2.3.10.2 600 Ω balanced line input

Where a 600 Ω balanced line is provided, the audio frequency response must be measured on this line.

2.3.10.2.1 Load the line with a 600 Ω resistive load or equivalent impedance, provided by the test instrument.

2.3.10.2.2 Inject a 1 kHz audio test signal into the line at a level of -10 dBm.

2.3.10.2.3 Ensure that the transmitting signal deviation comply with the standard test modulation factor.

2.3.10.2.4 Reduce the audio signal level to obtain 20 % of the maximum system deviation.

2.3.10.2.5 Proceed with test method A (2.3.10.1.2 to 2.3.10.1.5) or test method B (2.3.10.1.7 to 2.3.10.1.9)

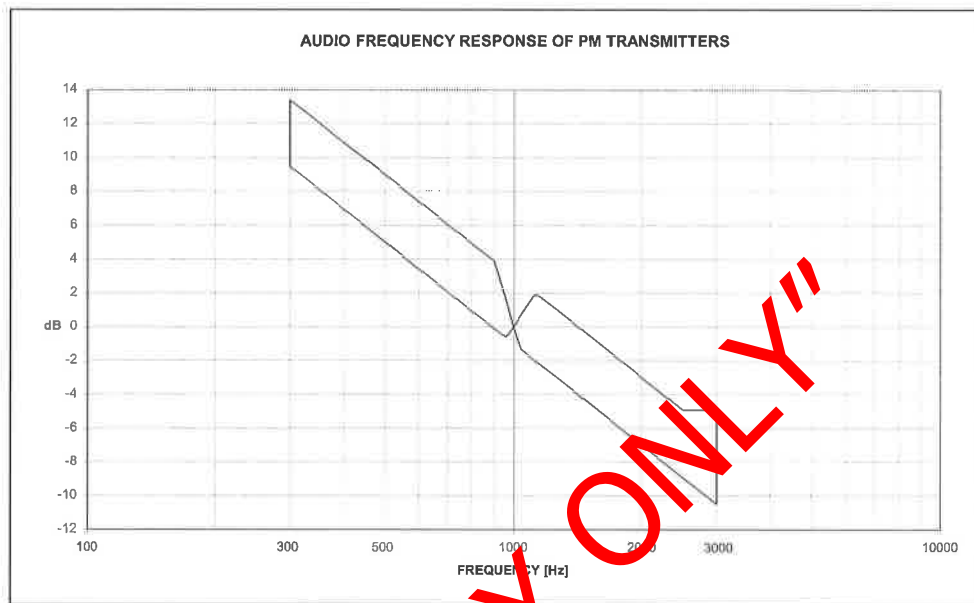

6dB/octave slope



2.3.11 Angle modulation hum and noise ratio

Connect the equipment as shown below.

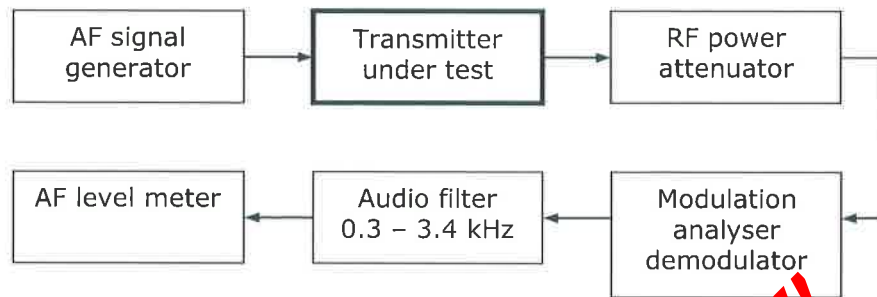

- 2.3.11.1 Apply electrically a 1 kHz audio test signal to the microphone input of the transmitter at a level sufficient to produce the standard test modulation factor.
- 2.3.11.2 Record the audio output level from the modulation analyser demodulator.
- 2.3.11.3 Remove the modulation from the transmitter.
- 2.3.11.4 Again record the audio output level from the modulation analyser demodulator.
- 2.3.11.5 Calculate the angle modulation hum and noise ratio by determining the difference between the two measurements in dB.

Note: Care must be taken not to generate hum when the audio signal is connected electrically.

Short circuit the audio input connections of the radio transmitter when the audio signal is removed.

2.3.12 Amplitude modulation hum and noise level

Connect the equipment as shown below.

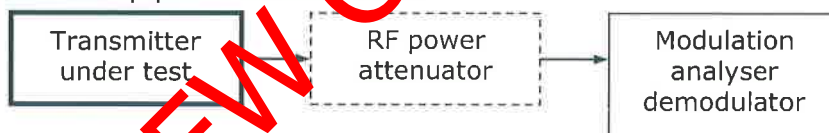

- 2.3.12.1 Set the modulation analyser to measure the RMS AM modulation factor (m %).
- 2.3.12.2 In the absence of an audio input signal (modulating signal) measure the modulation factor.
- 2.3.12.3 Calculate the AM hum and noise level as follow:

$$\text{AM hum and noise level (dB)} = 20\text{Log}(2 m/100)$$

2.3.13 Extreme transmitter loads

Connect the equipment as shown below.

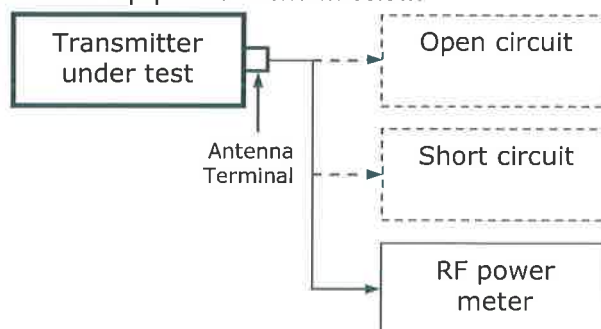

- 2.3.13.1 Measure the carrier power in the absence of modulation.
- 2.3.13.2 Operate the transmitter under open and short circuit load conditions for a period of:
 - 2.3.13.2.1 One minute each in the case of a transmitter rated for intermittent duty cycle.
 - 2.3.13.2.2 Five minutes each in the case of a transmitter rated for continuous operation.

-
- 2.3.13.3 After each exposure to the extreme load measure the carrier power in the absence of modulation.
 - 2.3.13.4 Calculate the variation of the carrier power in dB with reference to clause 2.3.13.1.

"PREVIEW COPY ONLY"

2.4 High Site Equipment

2.4.1 Radio Base Station Response Time

Connect the equipment as shown below.

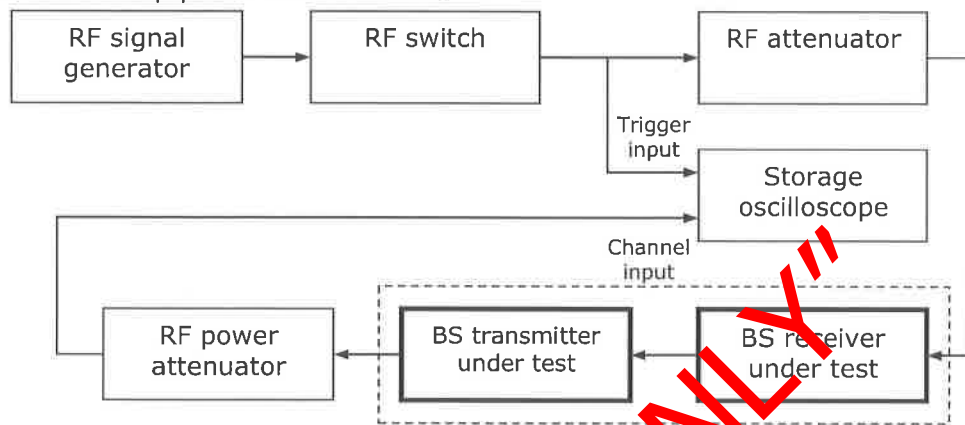

- 2.4.1.1 Apply a standard RF test signal to the receiver under test.
- 2.4.1.2 Determine the usable sensitivity as described in clause 2.2.3.
- 2.4.1.3 Adjust the squelch to open at a RF signal level of -115 dBm, measured at the antenna terminal.
- 2.4.1.4 Set the RF signal level 12 dB above the usable sensitivity level.
- 2.4.1.5 Set the storage oscilloscope to single sweep operation.
- 2.4.1.6 Enable the RF switch and measure the time required for the unmodulated transmit carrier voltage level to reach a value 6 dB (50 %) below the steady state level.
- 2.4.1.7 Repeat the measurement three times and take the average of the three measurements as the repeater attack time.

"PREVIEW COPY ONLY"

2.4.2 **Talk Through Signal**2.4.2.1 **Audio levels**

Connect the equipment as shown below.

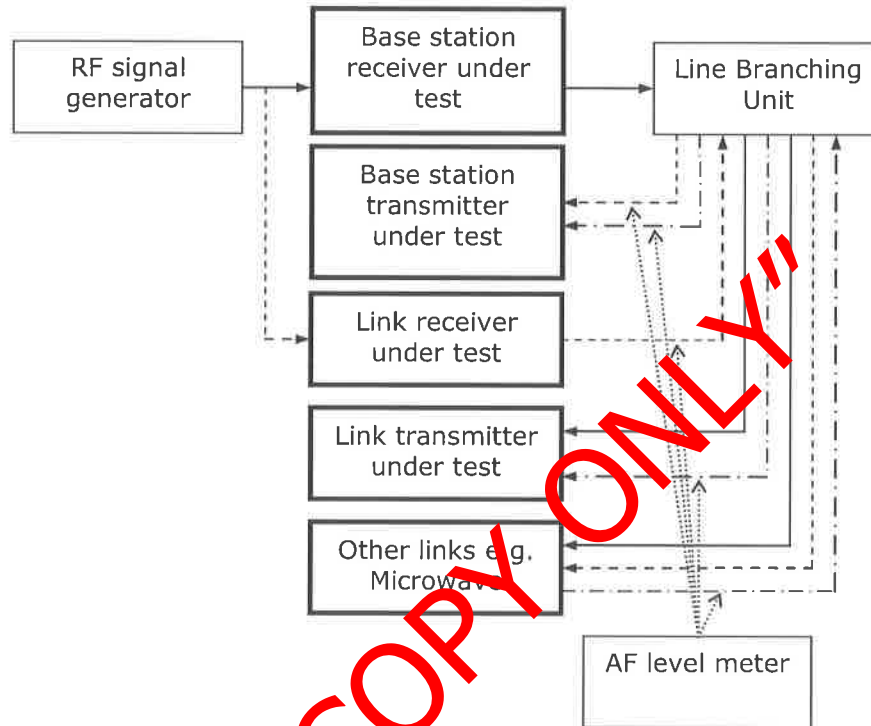

- 2.4.2.1.1 Adjust the RF signal generator to produce the standard RF test signal.
- 2.4.2.1.2 Connect the audio lines to the units as it would be connected when in operation. This is to ensure that the lines are correctly loaded.
- 2.4.2.1.3 Set the audio frequency level meter to high impedance/bridge mode. This is to ensure that the level meter does not load the lines.
- 2.4.2.1.4 Measure the audio level from the source (Rx) first. Adjust the level if necessary.
- 2.4.2.1.5 Measure all the outgoing lines from the LBU and adjust the levels if necessary.
- 2.4.2.1.6 Use the method described in clauses 2.4.2.1.1 to 2.4.2.1.4 to measure and adjust the audio level from the link receiver.
- 2.4.2.1.7 Measure the audio level from the microwave and adjust if necessary.

Note: The same measuring method is used on the Trunked radio equipment.

2.4.2.2 Audio Frequency Response

Connect the equipment as shown below.

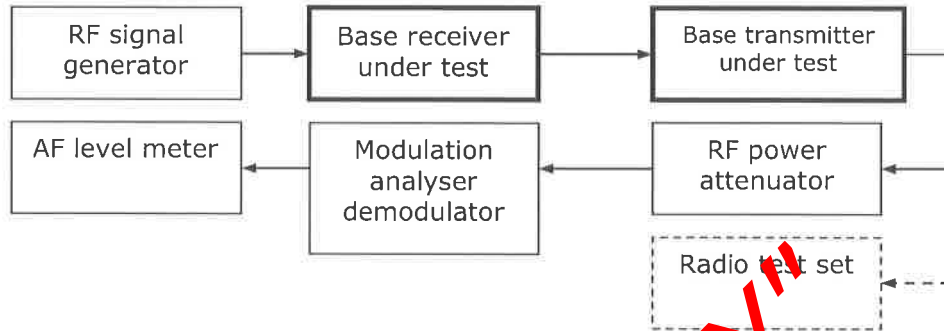

- 2.4.2.2.1 Ensure that all the audio level settings have been set correctly.
- 2.4.2.2.2 Adjust the RF signal generator to produce the standard RF test signal.
- 2.4.2.2.3 Select the low pass filter (cut-off 20 kHz) of the modulation analyser.
- 2.4.2.2.4 While keeping the modulation factor constant vary the modulating frequency over the range 300 Hz to 3 kHz.
- 2.4.2.2.5 Record the variation in the audio output power from the demodulator over this range in dB with reference to the corresponding level at 1 kHz.
- 2.4.2.2.6 Branches to the link radio and other links must also be measured.

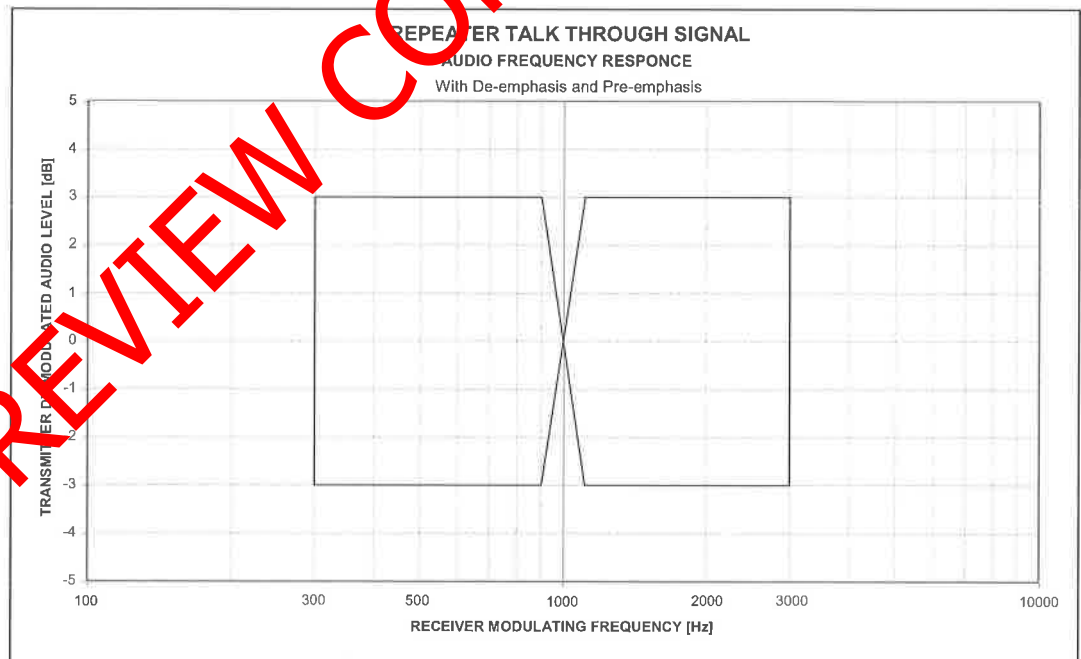

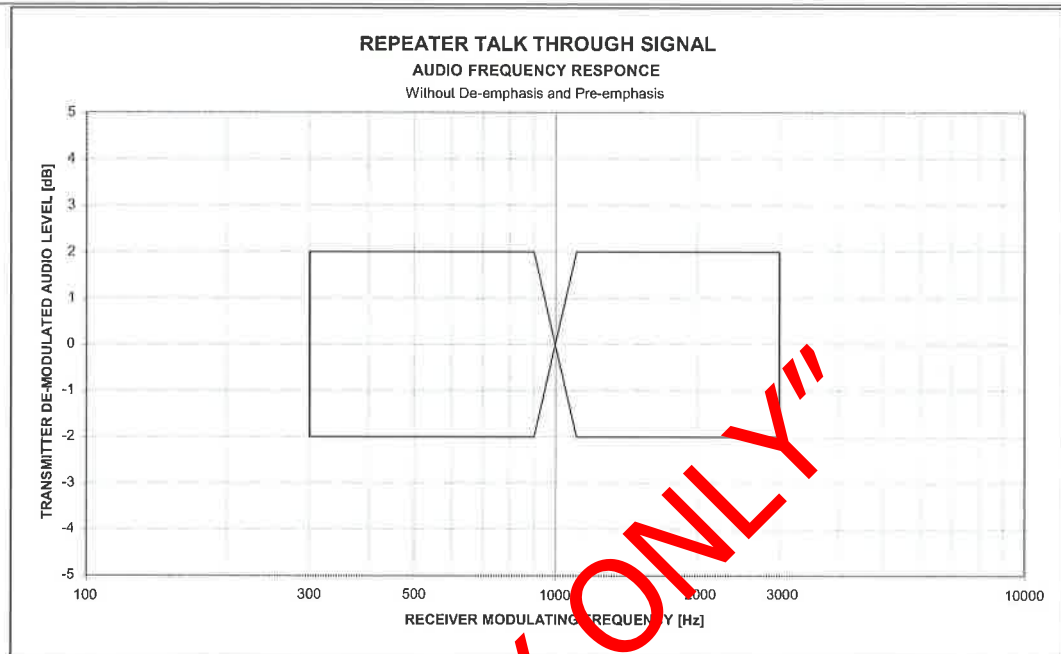

2.4.2.3 **Modulation factor linearity**

Connect the equipment as shown below:

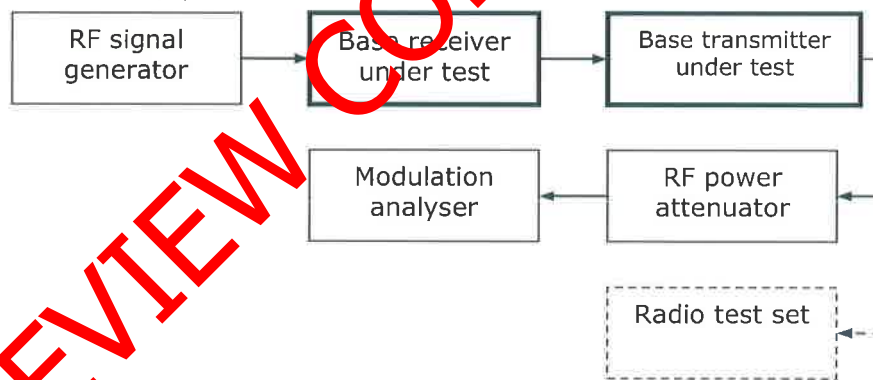

- 2.4.2.3.1 Ensure that the transmitter modulation limiting (deviation) has been set correctly (see clause 2.3.7).
- 2.4.2.3.2 Ensure that all the audio levels have been set correctly (see clause 2.4.2.1).
- 2.4.2.3.3 Apply a standard RF test signal from the RF signal generator to the receiver.
- 2.4.2.3.4 Vary the modulation of the RF input signal between 0.5 kHz and 2.5 kHz and measure the transmitter deviation.
- 2.4.2.3.5 Branches to the link radio and other links must also be measured.

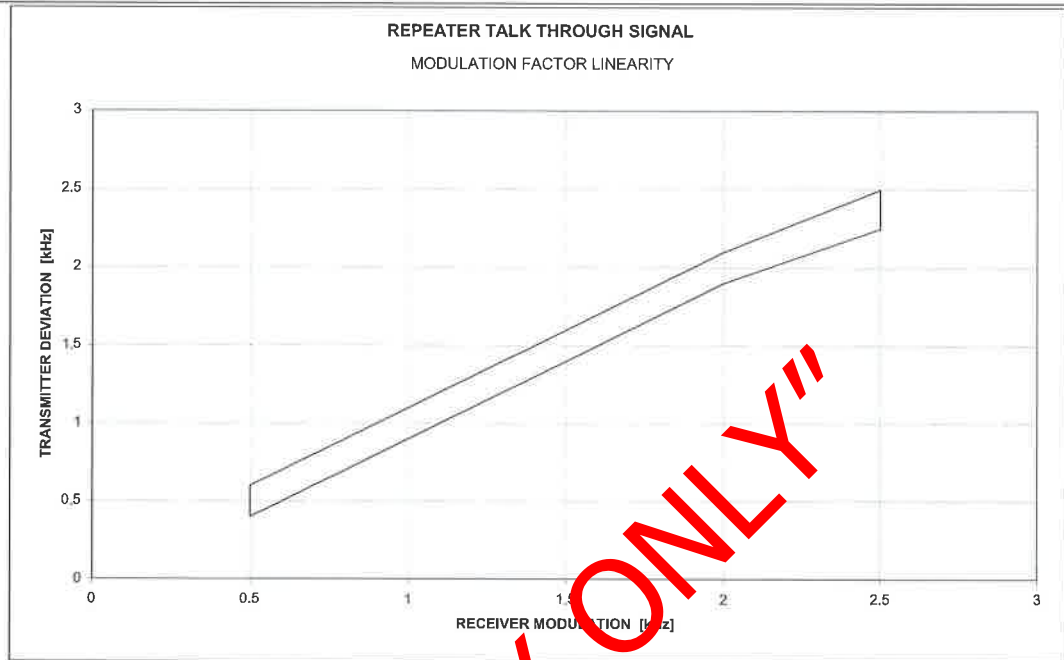

2.4.2.4

Audio frequency THD

Connect the equipment as shown below.

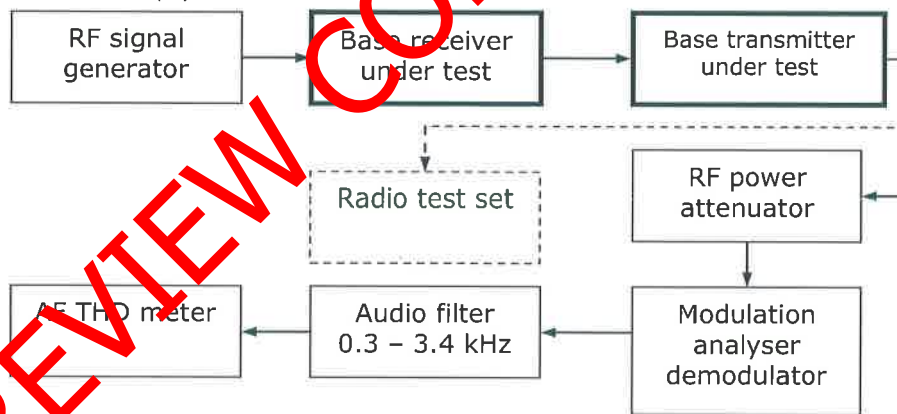

- 2.4.2.4.1 Ensure that all the audio levels are set correctly.
- 2.4.2.4.2 Apply a standard RF test signal to the receiver under test.
- 2.4.2.4.3 Record the audio total harmonic distortion from the transmitter.
- 2.4.2.4.4 Branches to the link radio and other links must also be measured.

2.4.3 Filters

2.4.3.1 Duplexer

The best method to check or tune a duplexer is to use a Transmission Line Analyser. This measuring method will not be covered in this document.

If any problem is detected the duplexer/combiner must be sent to a facility with the proper equipment and competency. Do not attempt to tune the unit.

A RF signal generator and a test receiver/spectrum analyser could be used to make measurements.

2.4.3.1.1 Calibration

2.4.3.1.1.1 Connect the RF signal generator with the two connecting cables to the test receiver or spectrum analyser.

2.4.3.1.1.2 Tune the RF signal generator and the test receiver/spectrum analyser to the in-band receiving/transmitting frequency to be measured.

2.4.3.1.1.3 Set the output level of the RF signal generator as required:

e.g. Low-level : ≤ -60 dBm
High-level : 0 dBm.

2.4.3.1.1.4 Record the difference between the applied and measured signal level. The difference must be included in the calculations.

Note: This method compensates for differences and the connecting cable losses.

2.4.3.1.2 Insertion loss - Rx

Connect the equipment as shown below.

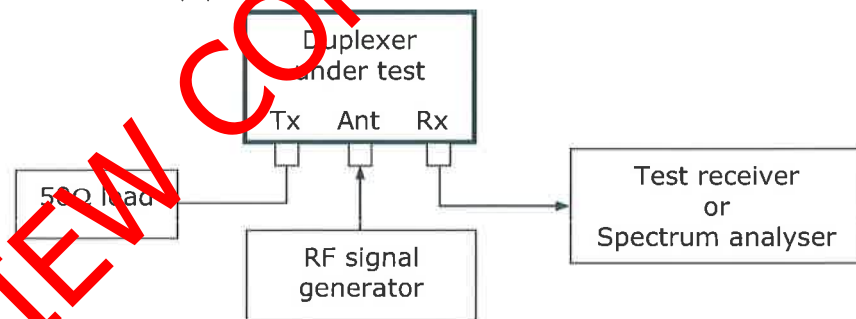

2.4.3.1.2.1 Tune the RF signal generator and the test receiver/spectrum analyser to the in-band receiving frequency to be measured.

2.4.3.1.2.2 Inject the signal at the antenna port (low level) and measure the level at the receiving port.

2.4.3.1.2.3 Calculate the insertion loss by determining the difference between the injected signal level and the measured level in dB.

2.4.3.1.2.4 The insertion loss must comply throughout the operating band.

At the high site this measurement can be made in the following way:

2.4.3.1.2.5 Connect the RF signal generator directly to the receiver.

2.4.3.1.2.6 Adjust the RF signal generator to produce a standard RF test signal.

2.4.3.1.2.7 Decrease the RF signal level till the squelch closes.

2.4.3.1.2.8 Increase the RF signal level **slowly** and note the level when the squelch open.

2.4.3.1.2.9 Connect the RF signal generator to the receiver via the duplexer (Ant port).

2.4.3.1.2.10 Repeat the procedure from clause 2.4.3.1.2.6 to 2.4.3.1.2.8.

2.4.3.1.2.11 Calculate the insertion loss by determining the difference between the two recorded signal levels in dB.

Note: When the result is within specification, the insertion loss through the coaxial cable between the receiver and duplexer can be ignored.

2.4.3.1.3 Insertion loss - Tx

Connect the equipment as shown below.

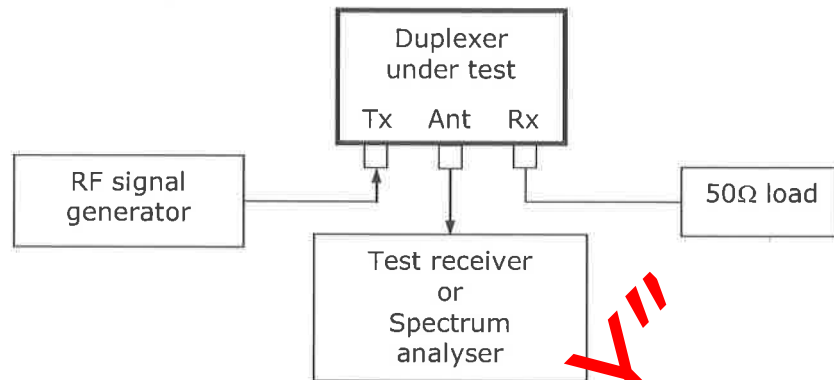

2.4.3.1.3.1 Tune the RF signal generator and the test receiver/spectrum analyser to the in-band transmitting frequency to be measured.

2.4.3.1.3.2 Inject the signal at the transmitting port (high level) and measure the level at the antenna port.

2.4.3.1.3.3 Calculate the insertion loss by determining the difference between the injected signal level and the measured level in dB.

2.4.3.1.3.4 The insertion loss must comply throughout the operating band.

At the high site this measurement can be made in the following way:

2.4.3.1.3.5 Connect a terminated wattmeter directly to the transmitter.

2.4.3.1.3.6 Measure the un-modulated carrier power from the transmitter.

2.4.3.1.3.7 Connect the same terminated wattmeter to the transmitter via the duplexer (Antenna port).

2.4.3.1.3.8 Measure the un-modulated carrier power from the transmitter.

2.4.3.1.3.9 Calculate the insertion loss by determining the difference between the two measured power levels in dB.

Note: When the result is within specification, the insertion loss through the coaxial cable between the transmitter and duplexer can be ignored.

2.4.3.1.4 Isolation between the transmitting and receiving paths

Connect the equipment as shown below.

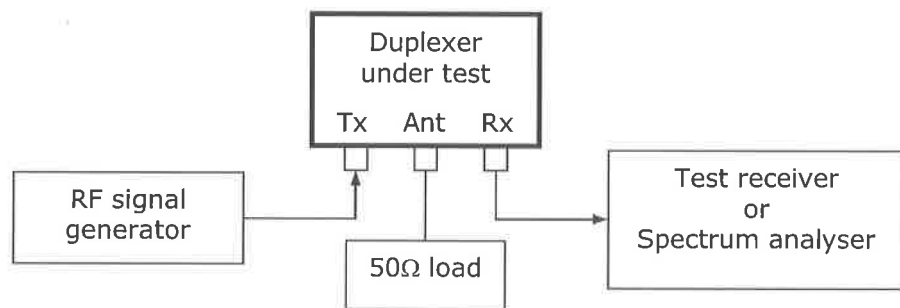

2.4.3.1.4.1 Tune the RF signal generator and the test receiver/spectrum analyser to the in-band transmitting frequency to be measured.

2.4.3.1.4.2 Inject the signal at the transmitting port (high level) and measure the level at the receiving port.

2.4.3.1.4.3 Calculate the isolation by determining the difference between the injected signal level and the measured level in dB.

2.4.3.1.4.4 The isolation must comply throughout the operating band.

2.4.3.1.5 **Impedance matching**

Connect the equipment as shown below.

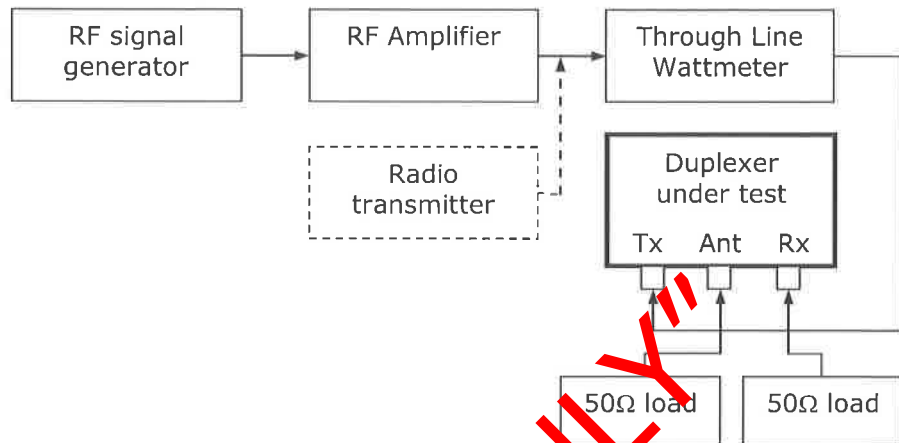

2.4.3.1.5.1 Tune the RF signal generator to the in-band transmitting frequency to be measured.

2.4.3.1.5.2 Measure the Voltage Standing Wave Ratio (VSWR) with a through line wattmeter.

2.4.3.1.5.3 If the wattmeter does not indicate the VSWR, note the forward and reflected power and calculate the VSWR

$$(1 + \sqrt{\text{Power reflected/Power forward}}) / (1 - \sqrt{\text{Power reflected/Power forward}})$$

2.4.3.1.5.4 The impedance matching must comply throughout the operating band.

2.4.3.1.5.5 Use the same method to measure the impedance at the receiver and antenna terminals.

2.4.3.2 **Combiner**2.4.3.2.1 **Insertion loss - Rx**

2.4.3.2.1.1 The insertion loss can be measured as explained in clause 2.4.3.1.2.

2.4.3.2.1.2 Fifty-ohm loads must be connected to all open transmitting and receiving ports.

2.4.3.2.1.3 The injected signal level at the antenna port must be low (≤ -80 dBm) to prevent the RF amplifier in the receiving path being saturated.

2.4.3.2.1.4 All the receiving ports must be measured.

2.4.3.2.1.5 The insertion loss must comply throughout the operating band.

2.4.3.2.2 **Insertion loss - Tx**

2.4.3.2.2.1 The insertion loss can be measured as explained in clause 2.4.3.1.3.

2.4.3.2.2.2 Fifty-ohm loads must be connected to all open transmitting and receiving ports.

2.4.3.2.2.3 All the transmitting ports must be measured.

2.4.3.2.2.4 The insertion loss must comply throughout the operating band.

2.4.3.2.3 **Isolation between the transmitting and receiving paths**

2.4.3.2.3.1 The isolation between the transmitting and receiving paths can be measured as explained in clause 2.4.3.1.4.

2.4.3.2.3.2 Fifty-ohm loads must be connected to all open transmitting and receiving ports.

2.4.3.2.3.3 All the ports must be measured.

2.4.3.2.3.4 The isolation must comply throughout the operating band.

2.4.3.2.4 Isolation between the transmitting ports

Connect the equipment as shown below

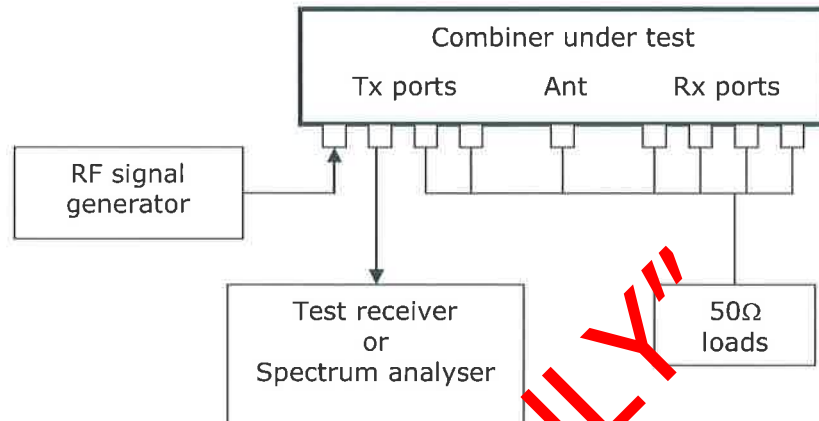

- 2.4.3.2.4.1 Tune the RF signal generator and the test receiver/spectrum analyser to the in-band transmitting frequency to be measured.
- 2.4.3.2.4.2 Fifty-ohm loads must be connected to the antenna- and all open transmitting and receiving ports.
- 2.4.3.2.4.3 Inject the signal at the first transmitting port (high level) and measure the level at the other transmitting ports.
- 2.4.3.2.4.4 Repeat step 2.4.3.2.4.3 when injecting the signal at ports 2 to 4.
- 2.4.3.2.4.5 Calculate the isolation by determining the difference between the injected signal level and the measured level in dB.
- 2.4.3.2.4.6 The isolation must comply throughout the operating band.

2.4.3.2.5 Impedance matching

- 2.4.3.2.5.1 The impedance matching can be determined as explained in clause 2.4.3.1.5.
- 2.4.3.2.5.2 Fifty-ohm loads must be connected to all open transmitting and receiving ports.
- 2.4.3.2.5.3 All the transmitting ports must be measured.

Note: **Do not** use this method to determine the impedance matching at the receiver and antenna terminals. If a problem is suspected, the combiner must be sent to a facility with the proper equipment and competency.

2.4.4 Coaxial Cable

2.4.4.1 Impedance matching

The best method to measure the impedance and insertion loss of the coaxial cable is to use a Transmission Line Analyser. This measuring method will not be covered in this document.

Connect the equipment as shown below.

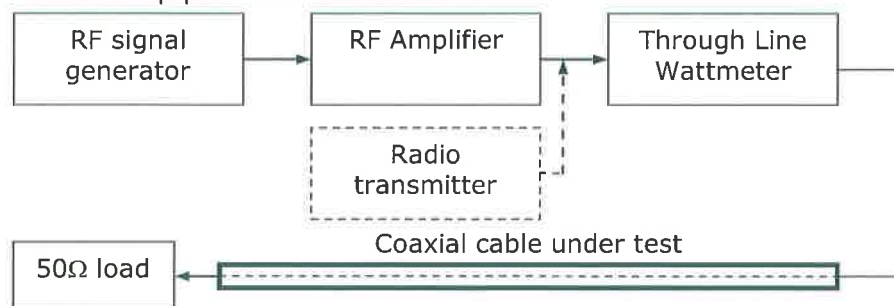

- 2.4.4.1.1 Tune the RF signal generator to the in-band transmitting frequency.
- 2.4.4.1.2 Measure the Voltage Standing Wave Ratio (VSWR) with a through line wattmeter.
- 2.4.4.1.3 If the wattmeter does not indicate the VSWR, note the forward and reflected power and calculate the VSWR (see clause 2.4.3.1.5.3).

- 2.4.4.1.4 Tune the RF signal generator to the in-band receiving frequency.
- 2.4.4.1.5 Measure the Voltage Standing Wave Ratio as above.
- 2.4.4.1.6 The impedance matching must comply throughout the operating band.
- 2.4.4.1.7 Record the worst case as the impedance matching.

2.4.4.2 **Insertion loss**

Connect the equipment as shown below.

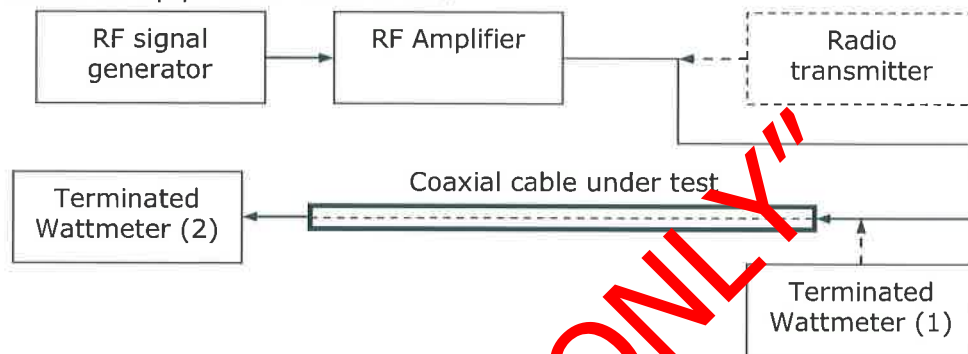

- 2.4.4.2.1 Tune the RF signal generator to the in-band transmitting frequency.
- 2.4.4.2.2 Measure the power at the near end of the coaxial cable using the terminated wattmeter (1).
- 2.4.4.2.3 Measure the power at the far end of the coaxial cable using the same terminated wattmeter (2).
- 2.4.4.2.4 Calculate the insertion loss by determining the difference between the power levels measured in dB.
- 2.4.4.2.5 Tune the RF signal generator to the in-band receiving frequency.
- 2.4.4.2.6 Repeat the measurements as above.
- 2.4.4.2.7 The insertion loss must comply throughout the operating band.
- 2.4.4.2.8 Record the highest loss measured, as the insertion loss.

2.4.5 **Antenna**

2.4.5.1 **Impedance matching**

The best method to measure the impedance of the antenna is to use a Transmission Line analyser. This measuring method will not be covered in this document.

Connect the equipment as shown below.

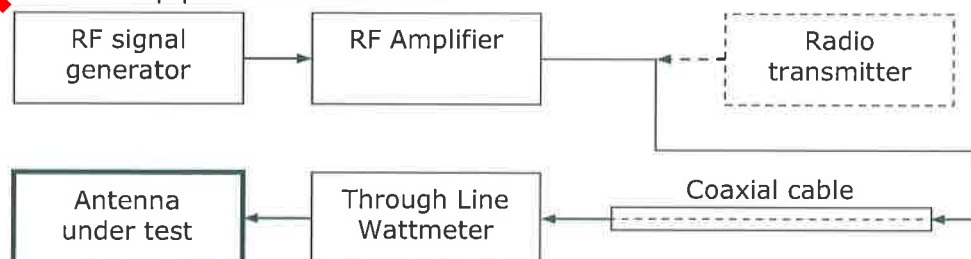

- 2.4.5.1.1 The impedance matching of the coaxial cable (clause 2.4.4.1) must be measured first.
- 2.4.5.1.2 Tune the RF signal generator to the in-band transmitting frequency.
- 2.4.5.1.3 Measure the Voltage Standing Wave Ratio (VSWR) with a through line wattmeter.
- 2.4.5.1.4 If the wattmeter does not indicate the VSWR, note the forward and reflected power and calculate the VSWR (see clause 2.4.3.1.5.3).
- 2.4.5.1.5 Tune the RF signal generator to the in-band receiving frequency.
- 2.4.5.1.6 Measure the Voltage Standing Wave Ratio as above.

- 2.4.5.1.7 The impedance matching must comply throughout the operating band.
 2.4.5.1.8 Record the worst case as the impedance matching.

2.4.5.2 **Effective Radiated Power (ERP)**

- 2.4.5.2.1 The effective radiated power is calculated as follows:
 The RF power measured into a $50\ \Omega$ load that replaces the antenna, times the gain of the antenna with reference to a Dipole antenna (dBd).
 2.4.5.2.2 The following calculation could also be used:
 Antenna gain (dBd) - Duplexer/combiner insertion loss (dB) - Coaxial cable insertion loss (dB) + Transmitting power at transmitter (dBm). Convert the result to Watts ($0.001 \times \text{Antilog}(\text{dB}/10)$).

2.4.6 **Receiver Desensitisation (Desensing)**

Connect the equipment as shown below.

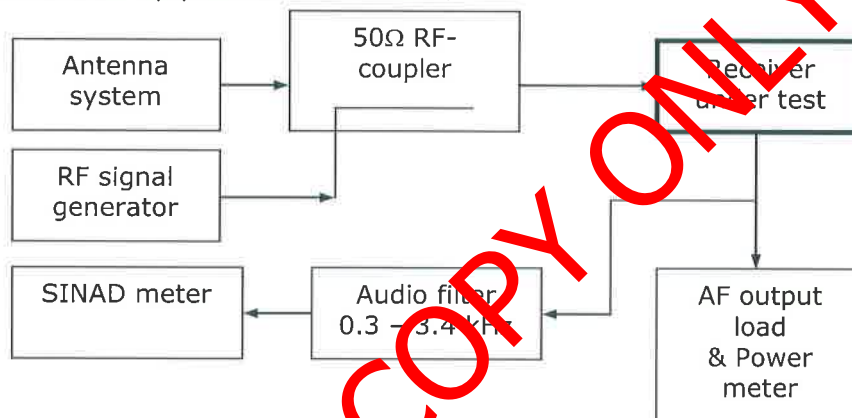

- 2.4.6.1 The transmitting power of all the transmitters must be set correctly.
 2.4.6.2 The insertion loss of the RF-coupler must be ≤ 1 dB.
 2.4.6.3 Adjust the RF signal generator to produce the standard test signal and apply it to the receiver via the RF-coupler.
 2.4.6.4 Reduce the RF signal output level until the SINAD ratio is 12 dB.
 2.4.6.5 Note the RF signal level at which the 12 dB SINAD is obtained.
 2.4.6.6 Transmit from the other transmitters situated on the site.
 2.4.6.7 Note if the SINAD ratio is degrading.
 2.4.6.8 If so, while transmitting increase the RF signal output from the generator to obtain a SINAD ratio of 12 dB.
 2.4.6.9 Note the RF signal level.
 2.4.6.10 Calculate the desensing level by determining the difference between the two measurements in dB.

2.4.7 **Audio Line Branching Unit (LBU)**

2.4.7.1 **Impedance matching**

Connect the equipment as shown below.

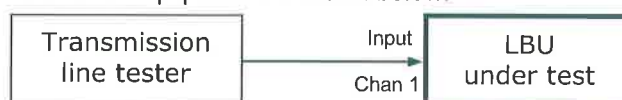

- 2.4.7.1.1 Switch the power of the LBU on.
 2.4.7.1.2 Measure the return loss of the input transformer to determine the impedance matching.

- 2.4.7.1.3 Repeat the measurement to determine the impedance matching of the other input and output terminals.

2.4.7.2 **Audio levels**

Connect the equipment as shown below.

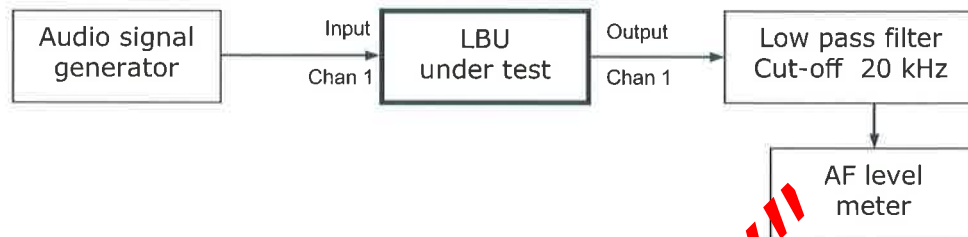

- 2.4.7.2.1 Ensure that the audio signal generator and audio level meter are set to the correct impedance.
- 2.4.7.2.2 Route all the input terminals to all the output terminals. This is required for the tests that follow.
- 2.4.7.2.3 Apply a 1 kHz signal at a level of -10 dBm into channel 1 of the LBU.
- 2.4.7.2.4 Measure the signal level at the output terminals of the LBU.
- 2.4.7.2.5 Adjust the output levels to obtain -10 dBm if necessary.
- 2.4.7.2.6 Repeat the measurements with the audio signal applied to the other input terminals.
- 2.4.7.2.7 All output levels should be -10 dBm without readjustment.

2.4.7.3 **Audio frequency response**

Connect the equipment as shown below.

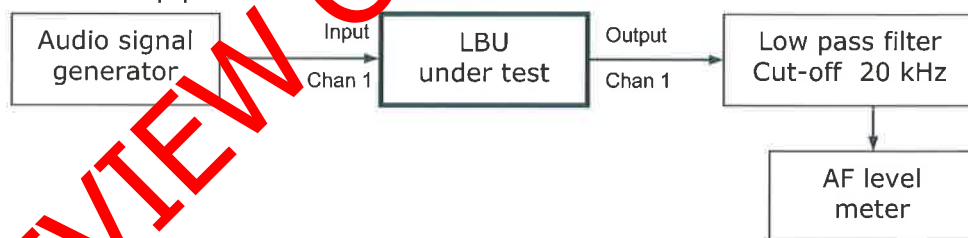

- 2.4.7.3.1 Ensure that all the audio levels are set correctly.
- 2.4.7.3.2 Apply a 1 kHz signal at a level of -10 dBm into channel 1 of the LBU.
- 2.4.7.3.3 Measure the signal level at the output terminal of channel 1.
- 2.4.7.3.4 While keeping the audio signal level constant vary the frequency from 300 Hz to 3 kHz.
- 2.4.7.3.5 Record the variation of the audio output level in dB with reference to the corresponding level at 1 kHz.
- 2.4.7.3.6 Repeat the measurements with the audio signal applied to the other input terminals.

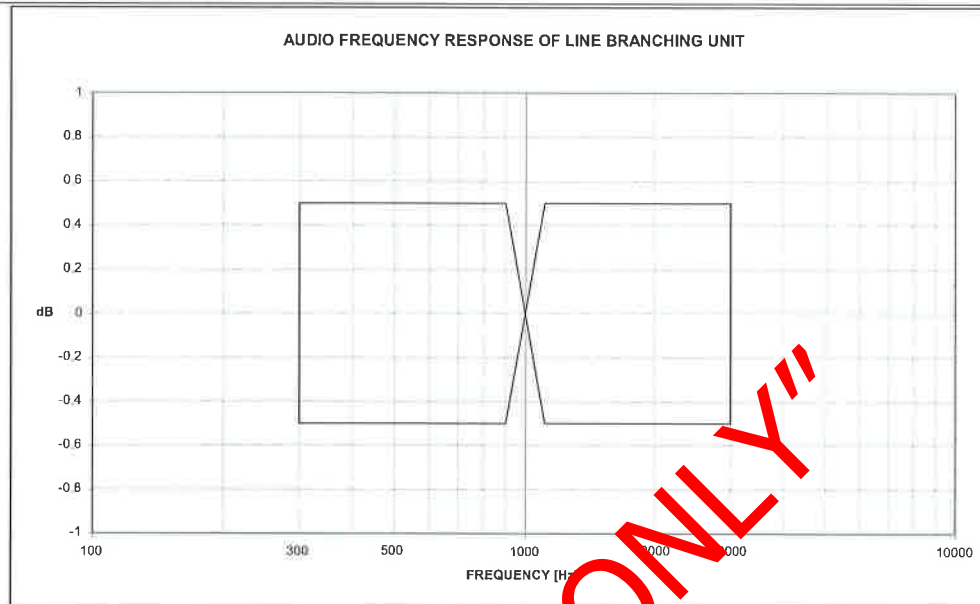

2.4.7.4 Audio total harmonic distortion (THD)

Connect the equipment as shown below.

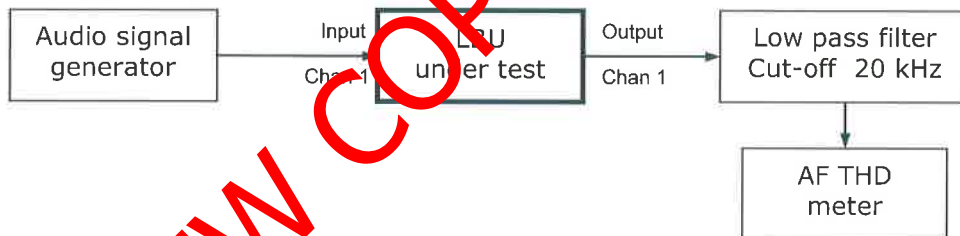

2.4.7.4.1 Ensure that all the audio levels are set correctly.

2.4.7.4.2 Route all the input terminals to all the output terminals.

2.4.7.4.3 Ensure that the audio signal generator and THD meter are set to the correct impedance.

2.4.7.4.4 Apply a 1 kHz signal at a level of -10 dBm into channel 1 of the LBU.

2.4.7.4.5 Record the audio total harmonic distortion obtained at the output terminals.

2.4.7.4.6 Repeat the measurements with the audio signal applied to the other input terminals.

2.4.7.5 Audio signal to hum and noise ratio

Connect the equipment as shown below.

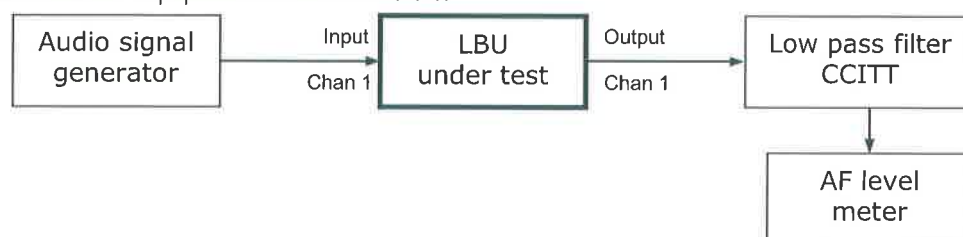

2.4.7.5.1 Ensure that all the audio levels are set correctly.

2.4.7.5.2 Route all the input terminals to all the output terminals.

2.4.7.5.3 Apply a 1 kHz signal at a level of -10 dBm into channel 1 of the LBU.

- 2.4.7.5.4 Short-circuit all the other input terminals.
- 2.4.7.5.5 Measure the signal level at the output terminals of the LBU.
- 2.4.7.5.6 Remove the audio signal generator and short circuit the input terminal (1) of the LBU.
- 2.4.7.5.7 Measure the signal level at the output terminals of the LBU.
- 2.4.7.5.8 Calculate the ratio in dB between the audio output levels obtained with and without the applied audio signal, as the signal to hum and noise ratio.
- 2.4.7.5.9 Repeat the measurements with the audio signal applied to the other input terminals.
- 2.4.7.5.10 Record the lowest ratio as the result.

2.4.7.6 **Channel cross talk**

Connect the equipment as shown below.

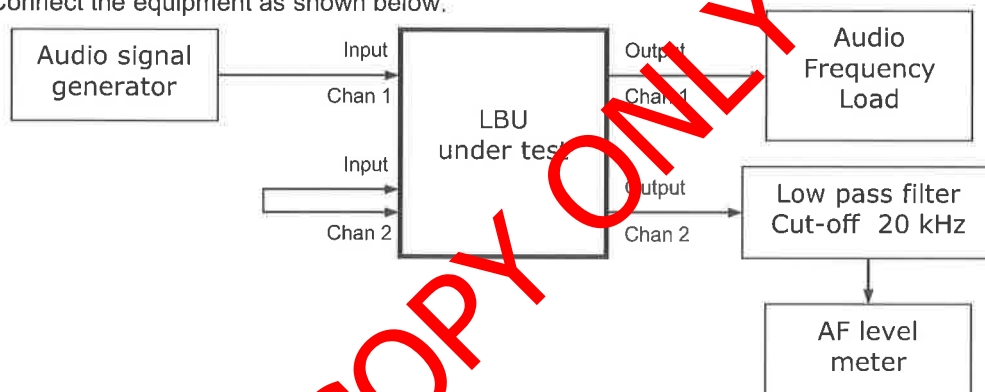

- 2.4.7.6.1 Route all the channels to operate separately e.g. Channel 1 input terminal to channel 1 output terminal; channel 2 input terminal to channel 2 output terminal; etc.
- 2.4.7.6.2 Ensure that all the level settings are correct for each channel.
- 2.4.7.6.3 Inject a 1 kHz signal at a level of -10 dBm into channel 1 of the LBU.
- 2.4.7.6.4 Short-circuit all the other input terminals.
- 2.4.7.6.5 Calculate the ratio in dB between the audio input signal level and that measured at the other output terminals, except that of channel 1.
- 2.4.7.6.6 Repeat the measurements with the audio signal injected into the other input terminals.
- 2.4.7.6.7 Record the worst case as the result.

2.4.7.7 **Common-mode rejection ratio**

Connect the equipment as shown below.

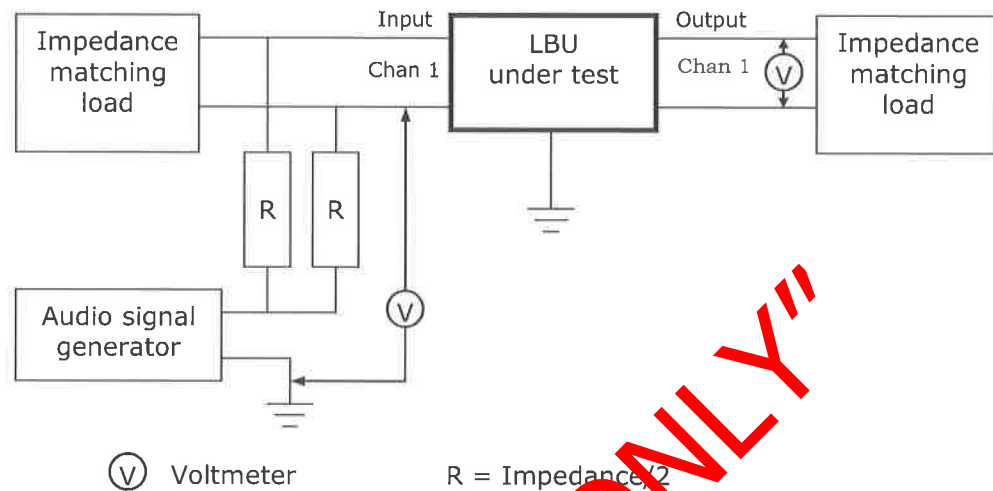

- 2.4.7.7.1 Adjust the amplification of the LBU to unity gain.
If the gain cannot be adjusted, measure the input and output voltage levels and calculate the gain.
- 2.4.7.7.2 Set the audio signal generator frequency to 1 kHz and set the output impedance to HIGH.
- 2.4.7.7.3 Increase the signal output level of the audio generator till the level measured on the output line of the LBU, also increases.
- 2.4.7.7.4 Record the input and output signal voltage levels.
- 2.4.7.7.5 If the LBU is set for unity gain, calculate the ratio in dB between the audio input signal level and that measured on the output line of the LBU.
OR
- 2.4.7.7.6 If the LBU has a gain, calculate the ratio by dividing the input voltage level by the output voltage level.
Multiply the calculated ratio with the gain of the LBU under tests and express the ratio in dB.
e.g. Input voltage/Output voltage = R:1
 $R \times \text{Gain} = T:1$
 $\text{dB} = 20\text{Log}_{10}(T/1)$
- 2.4.7.7.7 Repeat the measurement on the other channels.
- 2.4.7.7.8 Record the worst case as the result.

2.4.7.8 **E & M-signalling**

Connect the equipment as shown below.

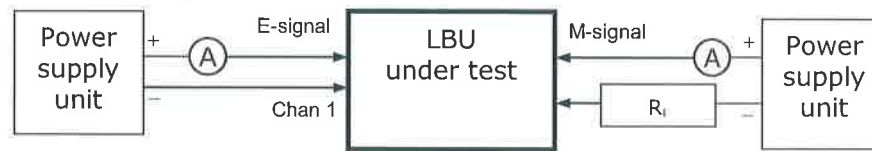

(A) Ammeter

- 2.4.7.8.1 Route the E-signal of channel 1 to activate the M-signal of all the channels.
- 2.4.7.8.2 The value of the load resistor R_L must be such to permit a current flow of 8 mA to 10 mA.
- 2.4.7.8.3 Apply a DC voltage at the appropriate level to the M signal terminal.
- 2.4.7.8.4 Apply a DC voltage at the appropriate level to the E signal terminal and measure the current.
- 2.4.7.8.5 Measure the current flow at all the M-signal terminals.
- 2.4.7.8.6 Reverse the voltage polarity at the E & M-signal terminals and repeat the test.
- 2.4.7.8.7 Repeat the above tests with other routing combinations.
- 2.4.7.8.8 Measure the resistance between the E & M-signal terminals and the LBU earth. The resistance must be infinity.

2.4.8 **Power Supply & Battery Charger Unit**2.4.8.1 **Output voltage regulation**

Connect the equipment as shown below.

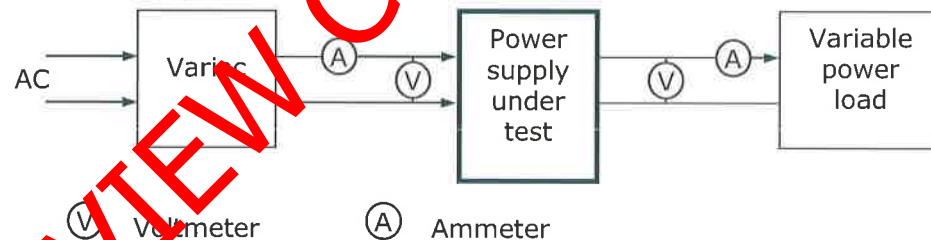

(V) Voltmeter

(A) Ammeter

- 2.4.8.1.1 Intermittent:
 - 2.4.8.1.1.1 Adjust the Variac to obtain the nominal input voltage to the power supply/battery charger.
 - 2.4.8.1.1.2 Vary the power load to obtain a current drain from 0 ampere to maximum current while recording the output voltage.
 - 2.4.8.1.1.3 The measurement shall be made under the extreme test conditions as well.
- 2.4.8.1.2 Continuous:
 - 2.4.8.1.2.1 Adjust the Variac to obtain the nominal input voltage to the power supply/battery charger.
 - 2.4.8.1.2.2 Set the power load to obtain the maximum current drain and record the output voltage level for a period of four hours.

2.4.8.2 **Efficiency**

Connect the equipment as shown below.

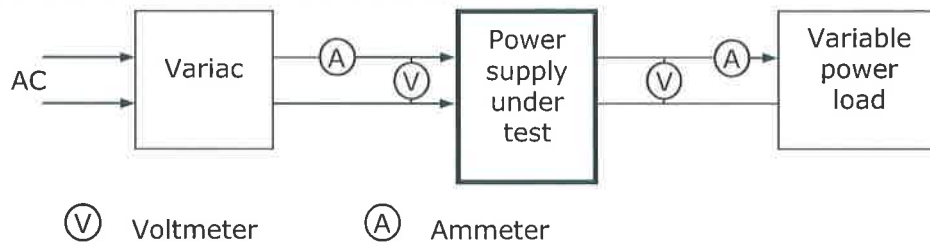

2.4.8.2.1 Adjust the Variac to obtain the nominal input voltage to the power supply/battery charger.

2.4.8.2.2 Vary the power load to obtain a current drain from 0 ampere to maximum current while recording the input and output voltages and currents.

2.4.8.2.3 Calculate the efficiency in percentage.

$$\text{Efficiency} = (\text{Power out}/\text{Power in}) \times 100\%$$

2.4.8.2.4 Repeat the test with the specified minimum, and then the maximum input voltage to the power supply/battery charger.

2.4.8.2.5 Record the worst case as the result.

2.4.8.3 **Output voltage ripple**

Connect the equipment as shown below.

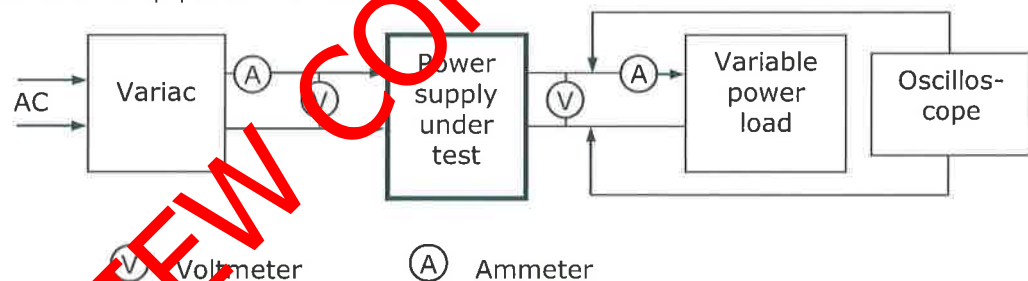

2.4.8.3.1 Adjust the Variac to obtain the nominal input voltage to the power supply/battery charger.

2.4.8.3.2 Vary the power load to obtain a current drain from 0 ampere to maximum current while recording the output voltage ripple with the oscilloscope.

2.4.8.3.3 The measurement shall be made under the extreme test conditions as well.

2.4.8.3.4 Record the worst case as the result.

Note: Some battery chargers apply high instantaneous pulses of short duration. In a Lead-acid battery, this breaks down lead-sulphate crystals, thus extending the battery service life. This function must be noted.

2.4.8.4 Radiation of spurious frequencies

Connect the equipment as shown below.

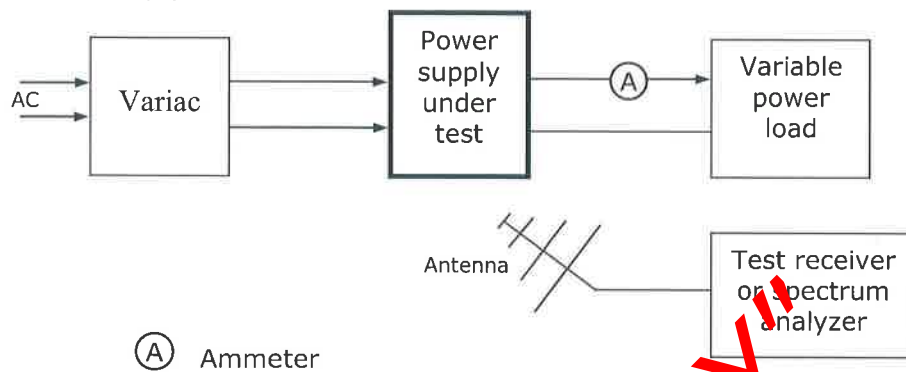

- 2.4.8.4.1 This test has to be performed inside a Faraday cage (RF shielding).
- 2.4.8.4.2 All the instruments and electrical equipment inside the cage not used for the test have to be switched off to prevent interference with the frequencies to be scanned. Ideally, all the equipment except the power supply under test and the antenna should be on the outside of the cage.
- 2.4.8.4.3 The measuring antenna to be placed 1 m from the power supply/battery charger.
- 2.4.8.4.4 Vary the power load to obtain a current drain from 0 ampere to maximum current while scanning the radio operating band (455.0000 MHz to 467.0000 MHz).
- 2.4.8.4.5 Record the frequencies and levels of all the detected signals.

2.4.8.5 Desensing of receiver (conductive)

Connect the equipment as shown below.

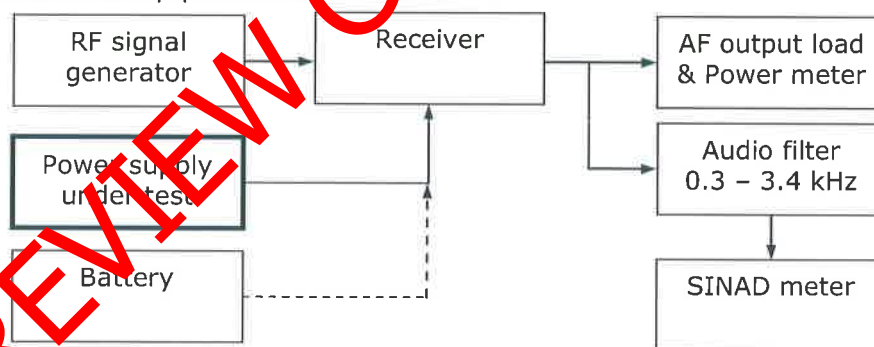

- 2.4.8.5.1 Use a battery to power the receiver.
- 2.4.8.5.2 Adjust the RF signal generator to produce a standard RF test signal.
- 2.4.8.5.3 Adjust the volume control of the radio to give SOP.
- 2.4.8.5.4 Reduce and record the RF signal input level at which 12 dB SINAD ratio is obtained.
- 2.4.8.5.5 Replace the battery with the power supply under test.
- 2.4.8.5.6 The length of the power leads to the radio must be 1.0 m.
- 2.4.8.5.7 Place the power supply as far as possible from the radio.
- 2.4.8.5.8 Readjust and record the RF signal output level at which 12 dB SINAD ratio is obtained.
- 2.4.8.5.9 Record the difference in dB between the recorded RF signal levels as the receiver desensing.

2.5 Trunking functional tests

Programme the radio under test with the correct trunking parameters and with a validated number on the trunk network.

1.5.1 On instrument

Connect the radio under test to the trunk enabled instrument.

1.5.1.1 Registration

Switch the radio on and ensure that it register on the instrument. The radio will display a registered indication and the instrument will display the radio's trunking number.

1.5.1.2 Make a call with the same prefix number (e.g. 2052001203 to 2052001204).

The instrument will display the called radio's prefix and the *derived* identification number.

1.5.1.3 Make a call with the interprefix number (e.g. interfleet call: 2052001203 to 2142001301).

The instrument will display the called radio's prefix and the *derived* identification number.

1.5.1.4 Short form dialling (e.g. 204)

Repeat 1.5.1.2 using the short form dialling.

1.5.1.5 PSTN call (e.g. 0117748227)

The dialled number must be presided with 0 (e.g. 00117748227). The instrument will display the called number.

1.5.1.6 Call the radio under test

Make a call to the radio from the instrument.

1.5.1.7 Handoff

Change the control channel on the instrument and ensure that the radio re-register on the new channel.

1.5.2 On trunk system

Two trunk radios and a PSTN telephone must be available and dedicated to the tests.

One trunk radio must be programmed with the same prefix number as the radio under test and the second radio with an interprefix number.

1.5.2.1 Registration

Switch the radio under test on and ensure that it register on the trunk system. The radio will display a registered indication.

1.5.2.2 Local call

Ensure that all the trunk radios are registered on the same local site.

1.5.2.2.1 Call a radio with the same prefix number

Call the radio having the same prefix number. Have a conversation with the second party.

1.5.2.2.2 Call a radio with an interprefix number

Call the radio having the interprefix number. Have a conversation with the second party.

1.5.2.2.3 Short form dialling

Repeat 1.5.2.2.1 using the short form dialling. Have a conversation with the second party.

1.5.2.2.4 Call the radio under test

Make a call to the radio under test from the other radios.

1.5.2.3 Intersite call

Move the radio under test to a distant site.

Ensure that the radio is registered on that site.

1.5.2.3.1 Call a radio with the same prefix number

Call the radio having the same prefix number. Have a conversation with the second party.

1.5.2.3.2 Call a radio with an interprefix number

Call the radio having the interprefix number. Have a conversation with the second party.

1.5.2.3.3 Short form dialling

Repeat 1.5.2.3.1 using the short form dialling. Have a conversation with the second party.

- 1.5.2.3.4 PSTN call
Call the PSTN telephone. Have a conversation with the second party.
- 1.5.2.3.5 Call the radio under test
Call the radio under test from the other radios. Have a conversation with the second party.
- 1.5.2.3.6 Handoff
Travel between sites and ensure that the radio under test re-register on the different sites.

Note: Call failures must be confirmed through different trunk sites.

2.6 Acoustical Measurements

2.5.1 Receiver loudspeaker sound pressure level

Connect the equipment as shown below.

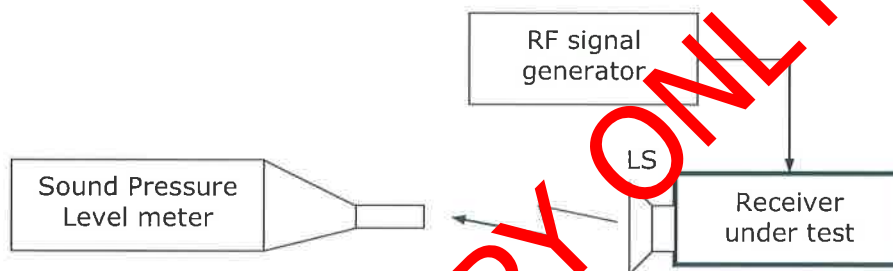

- 2.5.1.1 Adjust the RF signal generator to produce a standard RF test signal.
- 2.5.1.2 Increase the modulation to 2.5 kHz (maximum system modulation).
- 2.5.1.3 Adjust the volume control of the radio to obtain MUOP.
- 2.5.1.4 Place the Sound Pressure Level (SPL) meter at a distance of 300 mm in front of the radio loudspeaker.
- 2.5.1.5 Record the SPL in dB(A).

Note: Sound wave reflections should be kept to a minimum by measuring in an open area.

2.5.2 Transmitter modulation (deviation)

Connect the equipment as shown below.

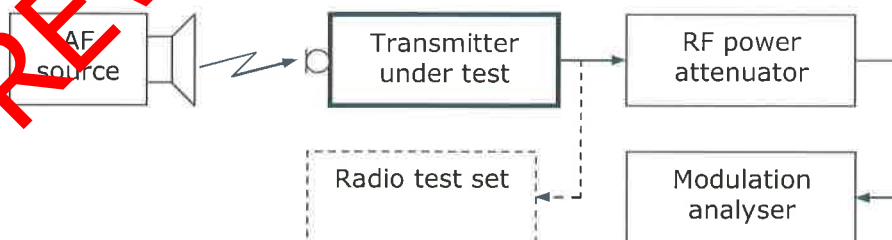

- 2.5.2.1 Ensure that the transmitter modulation limiting has been set correctly (see clauses 2.3.7).
- 2.5.2.2 Generate a 1 kHz tone with the AF source at a level of 80 dB(A), measured at the radio microphone.
- 2.5.2.3 Transmit and record the measured deviation.

Note: Sound wave reflections should be kept to a minimum by measuring in an open area.

3. RELEVANT DOCUMENTATION

APPLICABLE

DOCUMENT NO.	DESCRIPTION	LOCATION
SANS 300086-1:2005	Electromagnetic compatibility and Radio Spectrum Matters (ERM); Land Mobile Service; Radio equipment with an internal or external RF connector intended primarily for analogue speech Part 1: Technical characteristics and methods of measurement.	External

RELEVANT

DOCUMENT NO.	DESCRIPTION	LOCATION

END OF DOCUMENT

"PREVIEW COPY ONLY"



TRANSNET
freight rail

**RAIL NETWORK
TELECOMMUNICATION**

**SPECIFICATION
BBF 2516 VERSION 3.00**

**SPECIFICATION FOR UHF HANDHELD
TRUNKED AND CONVENTIONAL RADIO**

"PREVIEW COPY ONLY"

Author: Manager Rail Network
Telecommunication Radio

G. A Daly

Reviewed: Senior Engineer
Rail Network
Telecommunication Radio

M. Mmbengwa

Reviewed: Manager Regulatory
Rail Network
Telecommunication Radio

Y. Kedama

Authorised: Chief Engineer
Rail Network
Telecommunication

A. Matseke

Date 24 June 2014

Circulation Restricted To:

- Transnet Freight Rail
- Transnet and Relevant Third Parties
- Unrestricted

© This document as a whole is protected by copyright. The information herein is the sole property of Transnet Ltd. It may not be used, disclosed or reproduced in part or in whole in any manner whatsoever, except with the written permission of and in a manner permitted by the proprietors.

Contents

I.	Document Authorisation	I
II.	Distribution	I
III.	Document Change History	I
IV.	Changes since Last Revision	I
V.	List of Abbreviations and Acronyms	II
VI.	Relevant Documentation Applicable.....	III
1.	INTRODUCTION.....	1
2.	SCOPE.....	1
3.	COMPLIANCE.....	1
4.	TENDER REQUIREMENTS	2
5.	TECHNICAL REQUIREMENT.....	3
6.	TRAINING	5

"PREVIEW COPY ONLY"

I. Document Authorisation

FUNCTION	NAME	TITLE & DIVISION	DATE
Reviewed By:	Freddie Visser	Frequency Management Rail Network	26 June 2014
Reviewed By:	Chris Muller	Quality Assurance Rail Network	26 June 2014

II. Distribution

Once updated, a copy of the latest revision will be published on the document management system, "Project Wise".

III. Document Change History

ISSUE NO.	DATE ISSUED	ISSUED BY	HISTORY DESCRIPTION
1.00	October 2011	Robert Yates	New Document
2.00	November 2012	Graeme Daly	New Document
2.01	December 2012	Graeme Daly	Revised 5.17 & 5.18
2.02	May 2013	Graeme Daly	Signatory & Revision 4.1
3.00	June 2014	Graeme Daly	Revised Document

IV. Changes since Last Revision

CHANGES	DESCRIPTION
5.17 & 5.18	Channel Availability
5.17, 5.3 & Revised all clauses	Revised Document

V. List of Abbreviations and Acronyms

ABBREVIATIONS AND ACRONYMS	DESCRIPTION
AC	Alternating Current
Ah	Ampere hour
EC Amendment Act	Electronic Communications Amendment Act No.1 2014
BS	British Department of Trade and Industry Specification
dBm	Decibel relative to 1 milli watt
LED	Light Emitting Diode
m	Metre
mm	Millimetre
MPT	Minister of Post and Telecommunication
PTT	Press – To - Talk
RBU	Radio Base Unit
RCU	Remote Control Unit
RF	Radio Frequency
RTO	Radio Train Order
Rx	Receive
TFR	Transnet Freight Rail
THD	Total Harmonic Distortion
Tx	Transmit
UHF	Ultra High Frequency
V	Volt
W	Watt
Char	Character
CTC	Central Train Control
CTCSS	Continuous Tone Code Squelch System
dB(A)	Sound pressure A-weighted
DC	Direct Current
GPS	Global Positioning System
ICASA	Independent Communication Authority of South Africa
ID	Identification
IP	International Protection
mW	Milli watt
RF	Radio Frequency
TCO	Train Controlling Officer
UHF	Ultra High Frequency
VCO	Voltage Control Oscillator
VSWR	Voltage Standing Wave Ratio
NTC	National Test Centre
RFQ	Request for quotation

VI. Relevant Documentation Applicable

Where there is a conflict between the SPECIFICATION and SCHEDULE OF REQUIREMENT DOCUMENT, the SCHEDULE OF REQUIREMENT DOCUMENT takes precedence.

The equipment must comply with the latest issue of the following applicable specifications:

DOCUMENT NO.	DESCRIPTION	LOCATION
ISO 9000	Quality Management Systems.	External
ETSI EN 300 086	European Telecommunication Standards for Radios.	External
GG 3736	Electronic Communications Amendment Act No.1 2001	External
BS 3939	British Department of Trade and Industry Specification	External
MPT 1317	Code of Practice for Transmission of Digital Information over Land Mobile Radio Systems.	External
MPT 1327	A signalling Standard for Trunked Private Mobile Radio Systems	External
MPT 1343	System Interface Specification for Radio Units to be used with Commercial Trunked Networks.	External
BBD 8635 Version 8 22 May 2014	Technical specifications and methods of measurement for angle modulated equipment.	Internal
IP 54	Dust protected. Protected against splashing of water.	External
IP 55	Dust protected. Protected against water jets.	External
IP 57	Dust protected. Protected against the effect of immersion between 15 cm and 1 m.	External
IP 67	Totally protected against dust. Protected against the effect of immersion between 15 cm and 1 m.	External

1. INTRODUCTION

Transnet utilise UHF Handheld - Trunked and Conventional radio equipment, to control train shunting movements, communicate with train control officers, flagmen, shipping and harbours operations, etc.

2. SCOPE

- 2.1. This specification is for the supply of the above radio equipment and accessories as per attached Schedule of Requirements. **(Appendix A)**.
- 2.2. This specification will provide Bill of Quantities and Cost Schedule, as per attached. **(Appendix B & C)**
- 2.3. It is envisaged that equipment for this enquiry will be ordered and supplied to Transnet Freight Rail's nominated address. **(Appendix D & E)**.

3. COMPLIANCE

Item	Description	Comply Y/N	Remarks
3.1.	Tenderers shall submit a clause-by-clause statement of compliance for this Technical Specification BBF 2516 version 3.00, dated 6 June 2014, in the columns provided. *Failure to comply will exclude Tenderers from consideration.		
3.2.	Alternative offers, will be considered at Transnet Freight Rail's discretion, provided that such offers provide equivalent functionality to what has been specified in this document. Separate compliance documents must be completed for each alternative offer. (Appendix A- B & C – D & E) *Failure to comply will exclude Tenderers from consideration.		
3.3.	The successful bidder is obligated as per the Act to ensure Transnet is in possession of a valid frequency spectrum licence, for the Radio's to be supplied. A reference must be obtained from Transnet Frequency Spectrum Manager Mr Freddie Visser, at Freddie.Visser@Transnet.net or at 011 583 0125 prior to the delivery. *Failing to adhere to the above will result in the cancelation of this transaction and the matter will be reported to ICASA.		
3.4.	Radio's that comply with Technical Specifications BBD 8635 version 8, dated 21 May 2014 and this specification BBF 2516 version 3.00, dated 6 June 2014, but have not yet been submitted to Transnet for evaluation, must be submitted to the Transnet National Test Centre (NTC) to 2 Foley St. Factoria, Krugersdorp, Gauteng, attention Mr Chris Muller 011 774 8229 prior to, or, within 5 (Five) working days after the tender has closed. Approval letter from Transnet NTC must be included in the Tender/RFQ for each product offered. *Failure to comply will exclude Tenderers from consideration.		

Item	Description	Comply Y/N	Remarks
3.5.	All programming software, accessories, test interface box / cables, service manuals, ICASA certificate, etc. must submitted with the radio when being delivered to the NTC for evaluation. Refer to document BBD 8635, for requirements. *Failure to comply will exclude Tenderers from consideration		
3.6.	This Specification BBF 2516 must be read in conjunction with Technical Specification and Method of Measurement for Angle Modulated Radio Equipment BBD 8635 Version 8, dated 21 May 2014. *Failure to comply will exclude Tenderers from consideration		
3.7.	The equipment offered must be ICASA equipment type approved and a certificate per model offered must be submitted. *Failure to comply will exclude Tenderers from consideration.		
3.8.	Tenderers must provide a copy of their current ICASA Radio Dealers certificate. *Failure to comply will exclude Tenderers from consideration.		
3.9.	Radio's will be required to be batch tested by Transnet NTC prior to delivery or shipment. *Failure to comply will result in the termination of the order when radio equipment is delivered.		

4. TENDER REQUIREMENTS

Item	Description	Comply Y/N	Remarks
4.1.	Tenderers shall submit a clause-by-clause statement of compliance for equipment / items offered on the attached Schedule of Requirements (Appendix A) in the columns provided. *Failure to comply will exclude Tenderers from consideration.		
4.2.	Tenderers shall complete the attached Cost Schedule (Appendix B & C) for equipment. *Tenderers will be excluded from supplying any items not priced.		
4.3.	Tenderers shall complete the attached Delivery Schedule (Appendix D & E) for equipment. *Tenderers will be excluded from supplying if delivery dates are not included, as this will be a deciding factor.		

5. TECHNICAL REQUIREMENT

Item	Description	Comply Y/N	Remarks
5.1.	Technical specifications for items offered must be submitted. *Failure to comply will exclude Tenderers from consideration.		
5.2.	The Receiver loudspeaker must comply with a sound pressure level equal to or better than ≤ 84 dB (A) at 300 mm. Refer to document BBD 8635 version 8, dated 21 May 2014 for test method.		
5.3.	The Transmitter deviation must be between 300 - 500 Hz from sound pressure level of 80 dB (A) at the microphone. Refer to document BBD 8635 version 8, dated 21 May 2014 for test method.		
5.4.	Radios must be capable of handling a frequency switching bandwidth of 15 MHz on both transmit and receive between channels with no degradation.		
5.5.	Radios must be programmable in the 400 – 470 MHz band without signal degradation for component or board changes - to be specified.		
5.6.	Radio's must operate with 2, 5 kHz channel spacing.		
5.7.	The handheld radio RF output power must be software selectable between 1 and 4 watts, or to be specified.		
5.8.	In conventional mode, the handheld radio must have a maximum of 16 channels. (Can specify alternative number of channels)		
5.9.	The display on the radio must have a minimum of twelve alpha numeric characters.		
5.10.	It must be possible to assign an alpha – numeric label to each conventional channel.		
5.11.	Radios must be IP54 compliant or better.		
5.12.	Battery capacity must be capable of sustaining an 8 hour shift, with a duty cycle of 20, 20, 60. (Transmit, Receive, Standby)		
5.13.	Battery capacity to be declared in mAh.		

Item	Description	Comply Y/N	Remarks
5.14.	Battery chemical composition to be provided.		
5.15.	Battery Model number must be provided.		
5.16.	Radio key pad must have a lock - out facility after a channel has been selected.		
5.17.	Rotary channel selector switch must be able to be disabled with software.		
5.18.	Birth date of radio. (when was it released into the market)		
5.19.	Date expected to be withdrawn, superseded or replaced from the market. (Manufacture official letter to be provided)		
5.20.	Warranty period, exceptions, terms and conditions to be indicated.		
5.21.	Warranty period of radio to be indicated.		
5.22.	Warranty turn - around time for repairs to be specified in working days.		
5.23.	Supplier must prove that warranty repairs and technical support can be carried out on its own premises.		
5.24.	Spares and technical support must be readily available locally for a period of at least seven years from date of purchase.		
5.25.	All equipment returned from repairs must be fully aligned to meet the specification of compliance. Certification must be issued and random batch testing will be performed.		
5.26.	Service manuals must be in English and available on CD-ROM.		
5.27.	Programming software must be on CD-ROM.		
5.28.	Programming software must be Microsoft Windows 7 compatible.		
5.29.	The selection between Trunked and Conventional modes must be easily selectable.		

Item	Description	Comply Y/N	Remarks
5.30.	Trunked handheld radio must operate in accordance with MPT 1327 and MPT 1343 standards.		
5.31.	Trunked radio handheld must have a User Selectable inclusive and exclusive Group call facility catering for 100 Groups.		

6. TRAINING

Item	Description	Comply Y/N	Remarks
6.1.	Tenderers must be in a position to provide training on all products offered, country wide.		
6.2.	Training required on products will be indicated in the schedule of requirements.		

END OF DOCUMENT

"PREVIEW COPY ONLY"

RADIO SUPPLIERS

VENDOR No	VENDOR	CONTACT	TELEPHONE	E-MAIL
RADIO				
72024938	Multisource	Doret Saunders	011 321 0333 083 641 9284	Doret@multisource.co.za
72065532	Verstay	Bennie du Toit	011 979 3752 072 777 5150	bennie@verstay.co.za admin@verstay.co.za
72056353	Emcom SA	Rob Fryer	031 312 9288 083 346 5880	rob@emcom.co.za
72065845	Global Communications	Dumisani Nkosi	012 621 0427 082 326 6477	dnkosi@kenwoodsa.co.za
72059400	Altech	Noel Watermeyer	011 807 3185 083 893 4968	nwatermeyer@alcom.co.za
	Africa Radio Distributors	Johan Venter	011 777 8300 083 708 3418	Johan@ARadioD.co.za
	E & BC Agencies	Brian Cripwell	083 619 3333	enquiry@ebcom.co.za

"PREVIEW COPY ONLY"