

RFQ / TENDER

Tender No: AGG258



Vendor No: 11001386

BOARD LIST
BOARD LIST
TRANSNET FREIGHT RAIL
PROCUREMENT DEPARTMENT
2000

Purchaser : Antony Goldstone
Telephone : 033 897 2190
Fax Number: 086 522 6399

Please quote reference:
E60/6000621441

Deliver to:
The Manager
TRANSNET FREIGHT RAIL
INFRA; SIGNALS; LADYSMITH
MISS DINEO SERETLO 083-391-4478
3880 CNR LYLELL & ALEXANDRA STR L/S

Closing Date : 29.07.2016
Validity Date : 29.10.2016
RFQ No : 6000621441

12PM
Σ

PREVIEW COPY

1. RETURN OF QUOTATION/S:

SUPPLY & DELIVERY OF VDU & TOKEN BOARD SIGNAGE; AS PER SPECS;
FOR TFR TRACK WARRANT SYSTEM; FOR TFR INFRA SIGNALS LADYSMITH

PaDB REF:CRAC: _____ DEPOT REF: AGG258/LAY/SIG/010.

QUOTATIONS MUST BE EMAILED: TFRTENDERSDURBAN@transnet.net OR FAXED TO 011-584-1364

1.1 QUOTATION/S MUST BE SUBMITTED PUNCTUALLY AT 12:00 ON OR BEFORE CLOSING DATE AND LATE QUOTATIONS WILL NOT BE CONSIDERED.

1.2 IF POSTED: TFR SUPPLY CHAIN SERVICES TENDER ADMIN OFFICE
100 EEL ROAD
BAYHEAD
DURBAN
4000

1.3, IF DELIVERED BY HAND:
TRANSNET FREIGHT RAIL-SUPPLY CHAIN SERVICES
OFFICE D21; 100 EEL ROAD
BAYHEAD
DURBAN, 4000, TELEPHONE: 031-361-4123 CARROLL OR
: 031-361-4023 LINDIWE

2. CONDITIONS:

2.2 ANY PURCHASE ORDER PLACED AS A RESULT OF YOUR QUOTATION WILL BE SUBJECT TO THE STANDARD TERMS AND CONDITIONS OF CONTRACT, FORM US7, (LATEST), GENERAL TENDER CONDITIONS, FORM CSS5 (LATEST) AND

DATE:

SIGNATURE OF TENDERER(S):

CONTACT PERSON: TFI No:

RFQ / TENDER

Tender No: AGG258
Date : 20.07.2016

Page
2

BOARD LIST
TRANSNET FREIGHT RAIL
PROCUREMENT DEPARTMENT

CONDITIONS MENTIONED HEREIN.

2.3 TENDERERS MAY OFFER AN EARLIER VALIDITY DATE, BUT THEIR QUOTATION MAY, IN THAT EVENT, BE DISREGARDED FOR THIS REASON.

2.4 TENDERERS ARE REQUIRED TO OFFER ONLY FIRM PRICES. PRICES SUBJECT TO REVIEW IN TERMS OF CLAUSE 32 OF FORM U37 WILL ONLY BE CONSIDERED SHOULD THE DELIVERY PERIOD REQUIRED EXCEED 6 MONTHS.

2.5 BEST DELIVERY TIME MUST BE OFFERED.

2.6 DISCOUNT (TRADE DISCOUNT) CASH DISCOUNT (CONDITIONAL DISCOUNT) VALUE VALUE ADDED TAX (VAT) MUST BE SHOWN SEPARATELY.

2.7 TRANSNET RESERVES THE RIGHT TO NEGOTIATE PRICES AND COMMERCIAL ASPECTS AFTER THE CLOSING DATE OF THE QUOTATION.

PREVIEW COPY

DATE:

SIGNATURE OF TENDERER(S):

RFQ / TENDER

Tender No: AGG258
Date : 20.07.2016

Page
3

BOARD LIST
TRANSNET FREIGHT RAIL
PROCUREMENT DEPARTMENT

2.8 DIRECT DELIVERY INTIMATES DELIVERY BEING EFFECTED INTO THE WAREHOUSE OR THE ACTUAL POINT OF SUPPLY AND SHOULD THEREFORE INCLUDE ANY TRANSPORTATION MODE DEEMED NECESSARY IN EXECUTING THIS METHOD OF DELIVERY BASIS IN ORDER TO MEET THE REQUIRED DELIVERY DATE.

TAX CLEARANCE CERTIFICATES:

The Regulations in terms of the Public Finance Management Act, 1999: Framework for Supply Chain Management as published in Government Gazette No. 25767 dated 5 December 2003, Clause 9 (1) (d), stipulates that the accounting officer or accounting authority of an institution to which these regulations apply must reject any bid from a supplier who fails to provide written proof from the South African Revenue Service that the supplier either has no outstanding tax obligations or has made arrangements to meet outstanding tax obligations.

Tenderers will be disqualified if a valid tax clearance certificate or written proof from the South African Revenue Service that supplier has made arrangements to meet outstanding tax obligations is not submitted with the tender.

COMPANY DETAILS:

NAME OF COMPANY: _____

CONTACT PERSON: _____

TEL. NO. _____ FAX NO: _____

REG. NO. _____

EMAIL ADDRESS: _____

BROAD BASED BLACK ECONOMIC EMPOWERMENT (BBBEE)

Transnet fully endorses and supports the Government's Broad-based Black Economic Empowerment Programme and it is strongly of the opinion that all South African Business Enterprises have an equal obligation to redress the imbalances of the past. Transnet will therefore prefer to do business with local business enterprises who share those same values. Transnet will endeavour to do business with local business enterprises that possess a BBBEE "recognition level" of at least a level 5. Transnet urges Tenderers (large enterprises and QSE's - see below) to have themselves accredited by any one of the various Accreditation Agencies available, who do their BBBEE ratings in accordance with the latest Codes (i.e. those promulgated on 9 February 2007) and whose names appear on the present ABVA (Association of BEE Verification Agencies) - "List of Full Members" as displayed on the ABVA website (www.abva.co.za).

Although no agencies have, as yet, been accredited by SANAS (SA National Accreditation System), Transnet will, in the interim, accept rating certificates of tenderers who have been verified by any of the listed agencies.

Enterprises will be rated by such agency based on the following:

1. Large Enterprises (i.e. annual turnover > R35million:

" Rating level based on all seven elements of the BBBEE scorecard.

2. Qualifying Small Enterprises - (QSE) (i.e. annual turnover > R5million but < R35million:

" Rating based on any four elements of the BBBEE scorecard.

NB:

3. Emerging Micro Enterprises - (EME) (i.e. annual turnover < R5m) are exempted from being rated/verified:

DATE:

SIGNATURE OF TENDERER(S):

.....

RFQ / TENDER

Tender No: AGG258 Page
Date : 20.07.2016 4

BOARD LIST TRANSNET FREIGHT RAIL PROCUREMENT DEPARTMENT

- " Automatic rating of Level 4 BBEE irrespective of race of ownership, i.e. 100% BBEE recognition
- " Black ownership >50% or Black Women ownership >30% automatically qualifies as Level 3 BBEE, i.e. 110% BBEE recognition
- " EME's should provide certified documentary proof of annual turnover (i.e. audited financials) plus proof of Black ownership if Black ownership >50% or Black Women ownership >30% from the EME's Auditor/Accounting Officer.

4. In addition to the above, Tenderers who wish to enter into a Joint Venture or subcontract portions of the contract to BBEE companies, must state in their tenders the percentage of the total contract value that will be allocated to such BBEE companies, should they be successful in being awarded any business. A rating certificate in respect of such BBEE JV-partners and / or sub-contractor/s, as well as a breakdown of the distribution of the aforementioned percentage must also be furnished

In view of the high emphasis which Transnet places on Broad-based Black Economic Empowerment, Transnet will allow certain preference points for BBEE in the evaluation of all responses. Depending upon the value of the ensuing business award (i.e. below or in excess of R2m), the 80/20 or 90/10 point preference systems will be utilized where BBEE will count out of 20 or 10 respectively in the evaluation process.

EACH RESPONDENT IS REQUIRED TO FURNISH PROOF OF THE ABOVE TO TRANSNET. FAILURE TO DO SO WILL RESULT IN A SCORE OF ZERO BEING ALLOCATED FOR BBEE.

Turnover: Kindly indicate your company's annual turnover for the past year R_____

- " If annual turnover <R5m, please attach certified confirmation from your Auditor/Accounting Officer
- " If annual turnover >R5m please attach original or certified copy of accreditation certificate and detailed scorecard by an ABVA accreditation agency (registered as a "Full Member")

PAYMENT TERMS

The following payment terms will apply as from 1 October 2008.

- " All suppliers will be paid 30 days from receipt of month end statement, i.e. payment term F055.

CONDITIONS:

This quotation is subject to the provisions of the Standard Terms and Conditions of Contract, Form US7, (Latest) and the General Tender Conditions, Form CSS5 (Latest) and any other standard or special conditions mentioned and/or embodied in the quotation request.

SCHEDULE OF REQUIREMENTS

PRICES TENDERED ARE TO BE "DIRECT" AND EXCLUDE VAT.

IN THIS REGARD THE TENDERER'S ATTENTION IS DIRECTED TO PARAGRAPH 16 OF FORM CSS5 (LATEST).

DATE:

SIGNATURE OF TENDERER(S):

.....

RFQ / TENDER

Tender No: AGG258 Page
Date : 20.07.2016 5

BOARD LIST TRANSNET FREIGHT RAIL PROCUREMENT DEPARTMENT

TRANSNET INSISTS ON HONESTY AND INTEGRITY BEYOND REPROACH AT ALL TIMES AND WILL NOT TOLERATE ANY FORM OF IMPROPER INFLUENCING, BRIBERY, CORRUPTION, FRAUD, OR ANY OTHER UNETHICAL CONDUCT ON THE PART OF BIDDERS/ TRANSNET EMPLOYEES. IF, IN THE OPINION OF TRANSNET'S CHIEF OPERATING OFFICER, A TENDERER / CONTRACTOR / SUPPLIER HAS OR HAS CAUSED TO BE PROMISED, OFFERED OR GIVEN TO ANY TRANSNET EMPLOYEE, ANY BRIBE, COMMISSION, GIFT, LOAN, ADVANTAGE OR OTHER CONSIDERATION, TRANSNET SHALL BE ENTITLED TO REVOKE THE TENDER / CONTRACT BY FOLLOWING ITS INTERNAL POLICIES THAT GOVERN THE EXCLUSION PROCESS. IN SUCH AN EVENT TRANSNET WILL BE ENTITLED TO PLACE ANY TENDERER / CONTRACTOR / SUPPLIER WHO HAS CONTRAVENED THE PROVISIONS OF TRANSNET'S BUSINESS ETHICS ON ITS LIST OF EXCLUDED TENDERERS. THIS LIST WILL ALSO BE DISTRIBUTED TO ALL OTHER STATE OWNED ENTERPRISES AND GOVERNMENT DEPARTMENTS.

TRANSNET INVITES ITS VALUED SUPPLIERS TO REPORT ANY ALLEGATIONS OF FRAUD & CORRUPTION OR OTHER UNETHICAL ACTIVITIES TO TRANSNET TIP-OFFS ANONYMOUS, AT ANY OF THE FOLLOWING ADDRESSES / CONTACT NUMBERS:-

TOIL-FREE ANONYMOUS HOTLINE - 0800 003 056
EMAIL - Transnet@tip-offs.com
FAX NUMBER - 0800 007 788
FREEPOST DN 298, UMHLANGA ROCKS, 4320

CONFIDENTIALITY IS GUARANTEED

Item	Qty	Material	Description	R.....
00010	1		SUPPLY & DELIVER VDU & TOKEN BOARDS	Each

Delivery Date: 30.08.2016

FULL DETAILS OF DESCRIPTION TO SUPPLY & DELIVERY OF

2 EACH: VDU BOARDS
9 EACH: TOKEN BOARDS

AS PER SPECS SUPPLIED & AS PER TRANSNET SAFETY SIGNAGE MANUAL SPECIFICATIONS.

DATE:

SIGNATURE OF TENDERER(S):



TRANSNET
freight rail

A Division of Transnet Limited

**RAIL NETWORK
TECHNICAL
TRAIN AUTHORISATION SYSTEMS
PURCHASE SPECIFICATION**

**SUPPLY AND DELIVERY OF VDU & TOKEN BOARDS FOR
VDU TRACK WARRANT SYSTEM
(LADYSMITH DEPOT)**

PREVIEW COPY

1. **SCOPE**

SUPPLY AND DELIVERY OF VDU & TOKEN BOARDS FOR VDU TRACK WARRANT (LADYSMITH DEPOT).

2. **SPECIFICATIONS AND STANDARDS**

The required material shall comply with the specifications and standards as set out in this document. These will be installed in the Ladysmith area. Token boards must also have mounting clamps and uni strut, below is what must be written on the VDU boards.

DANSKRAAL CTC VDU 5 CONTACT TCO

VDU & TOKEN BOARDS for VDU track Warrant	
Description	Quantity
VDU Boards	8
TOKEN Boards	9

PREVIEW COPY

END OF SPECIFICATION

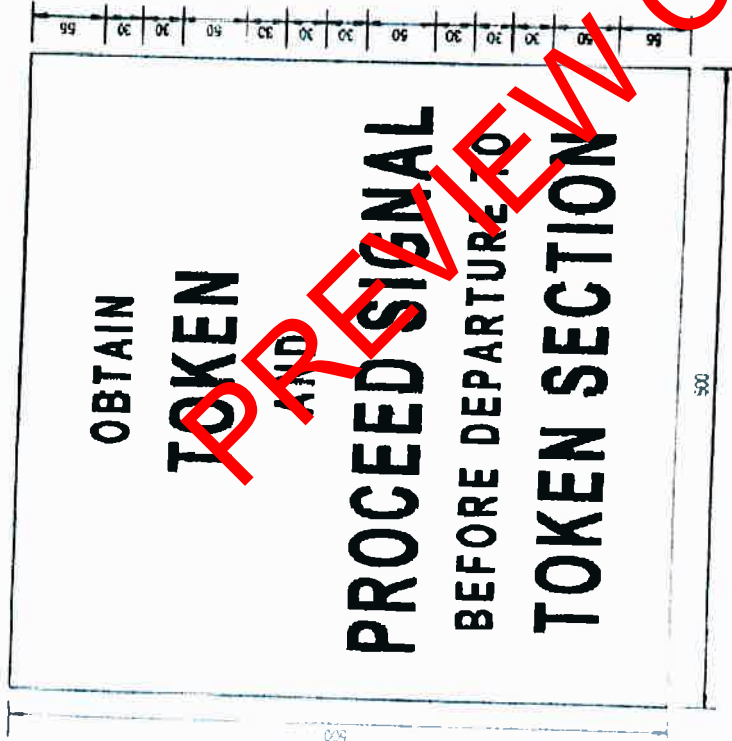

NOTES

- 1) BOARD TO BE FAINTED WRITE ON BOTH SIDES
- 2) LETTERING TO BE BLACK
- 3) BOARD TO BE FITTED TO A SUITABLE METAL FRAME
- 4) WHERE NECESSARY THE BOARD CAN BE MOUNTED OFF-CENTRE ON THE SIGNAL POLE TO COMPLY WITH STRUCTURE GAUGE CLEARANCES.



© COPYRIGHT PROTECTED

DIMENSIONS
TOLERANCE
MATERIAL
CP REF
VERSION INF
ITEM NO

SCALE 1:5

COO REF CDD/1034
DRAWN SR
DESIGNED
CHECKED PK

DATE: 02/01/04-04
APPROVED
AUTHORISED

CENTRAL DRAWING OFFICE (INFRASTRUCTURE)

**BOARD: SIGNAGE AT STARTER SIGNALS
AT COLOUR LIGHT -
TOKEN SYSTEMS INTERFACE**

SPOORNET
BBB1723
VERSION :
M

Document Reference: VDU Board Specifications

Safety Signage Manual

PREVIEW COPY

TRANSNET



delivering on our commitment to you

freight rail

Emergency Black

Pantone®: PMS Black

Process: oc om oy 100k

Vinyl: Avery 801 Black or an
SABS-approved vinyl to
match PMS Black

White Reflective finish to signboard

PREVIEW COPY

All frames, and
clamps to be galvanised
prior to painting.
Any sections cut post
galvanising must be
re-treated for anti-
corrosive purposes.

COLOUR:

- 1 PMS 5767
- 2 REFLECTIVE WHITE
- 3 PROCESS BLACK
- 4 PMS 165
- 5 AVERY 856
- 6 PMS 2728

PLEASE NOTE:

- This drawing is issued for quotation purposes only, not for construction.
- All dimensions in millimetres unless otherwise stated.
- Do not scale from drawing.
- All dimensions to be checked by contractor before commencing production.
- Any change in specification or manufacture procedure or material choice, must be approved prior to full manufacture being commissioned.
- No reproductions are permitted without written consent.

2. The basics

Typography

Typography or the technique of arranging the type and type design plays an important role in ensuring legibility of signs. By using a font consistently, it is possible to create a cohesive language across all safety signage. Where words are needed to give further explanation of safety signs, the same family of font should be used. The Apex Sans typeface was chosen because it is legible, reproduces well and has a good family of weights. Apex Sans is also Transnet's corporate font.

Apex Sans

Aa

FRONT VIEW

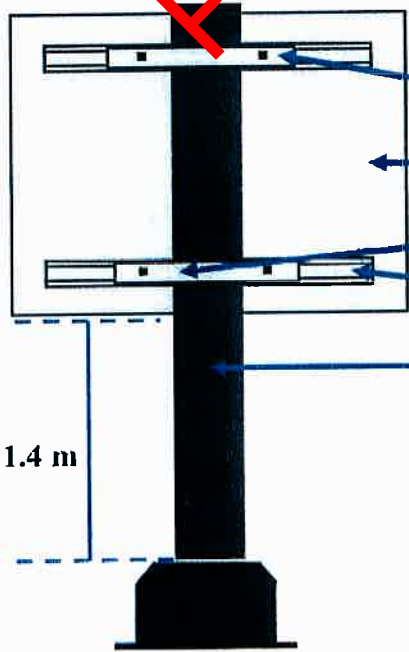

Nut & bolt

1.4 Chromadek

Mounting clamp

Uni strut

Mast

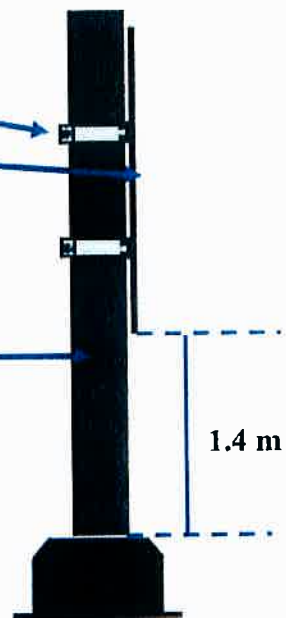

6. Application guidelines

Rail sign placement

Each Infrastructure depot engineer must sign off the placement of rail line signage. The placement of rail line signage is subject to the regulations as outlined in:

- 1 THE MANUAL FOR TRACK MAINTENANCE 2000 (BBB0481)
- 2 RELEVANT ELECTRICAL SAFETY INSTRUCTIONS
- 3 SADC ROAD TRAFFIC SIGNS MANUAL, VOLUME 7

PREVIEW COPY