

1 2 3 4 5 6 7 8

A

B

C

D

E

F

A

B

C

D

E

F

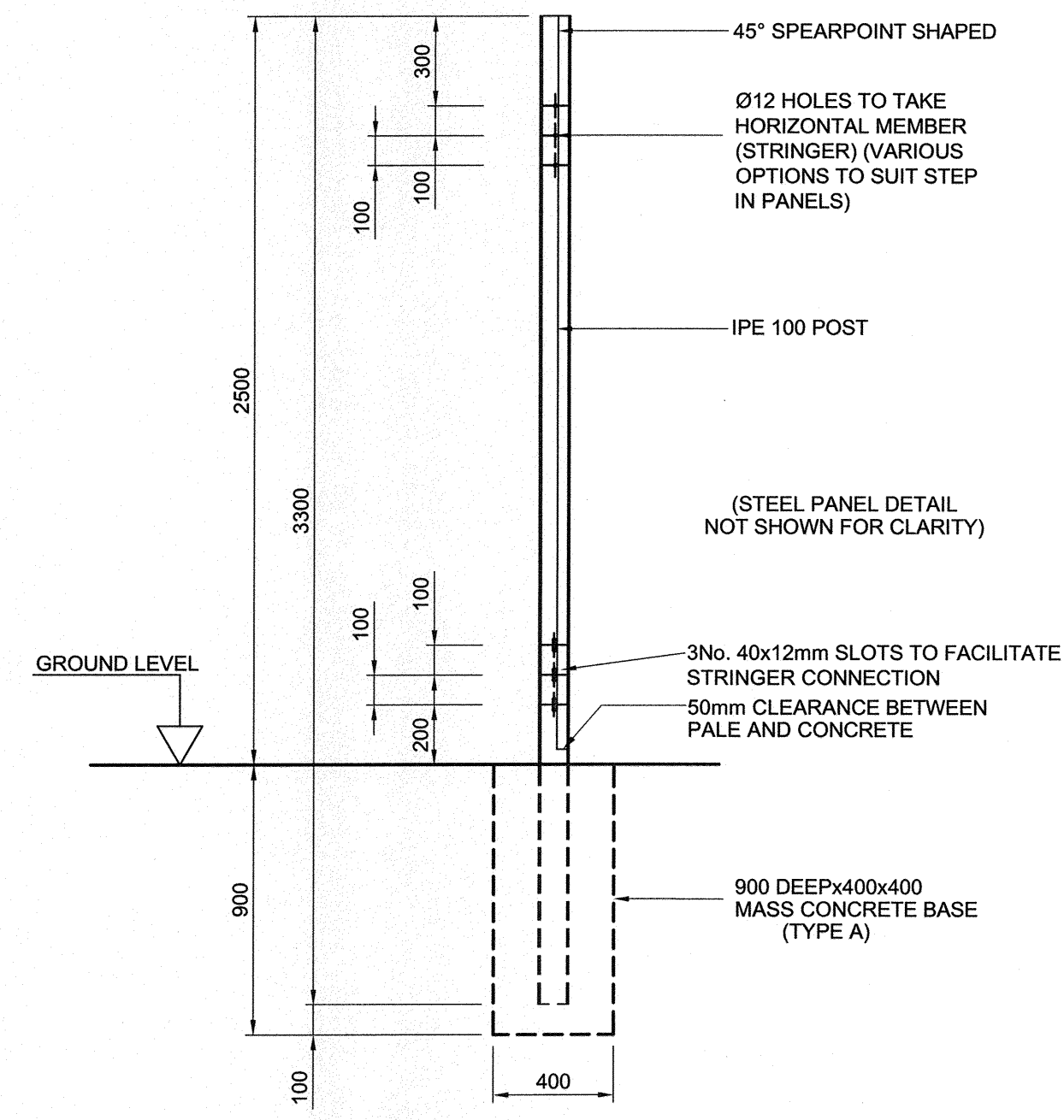

TYPICAL SECTION A-A
1:20

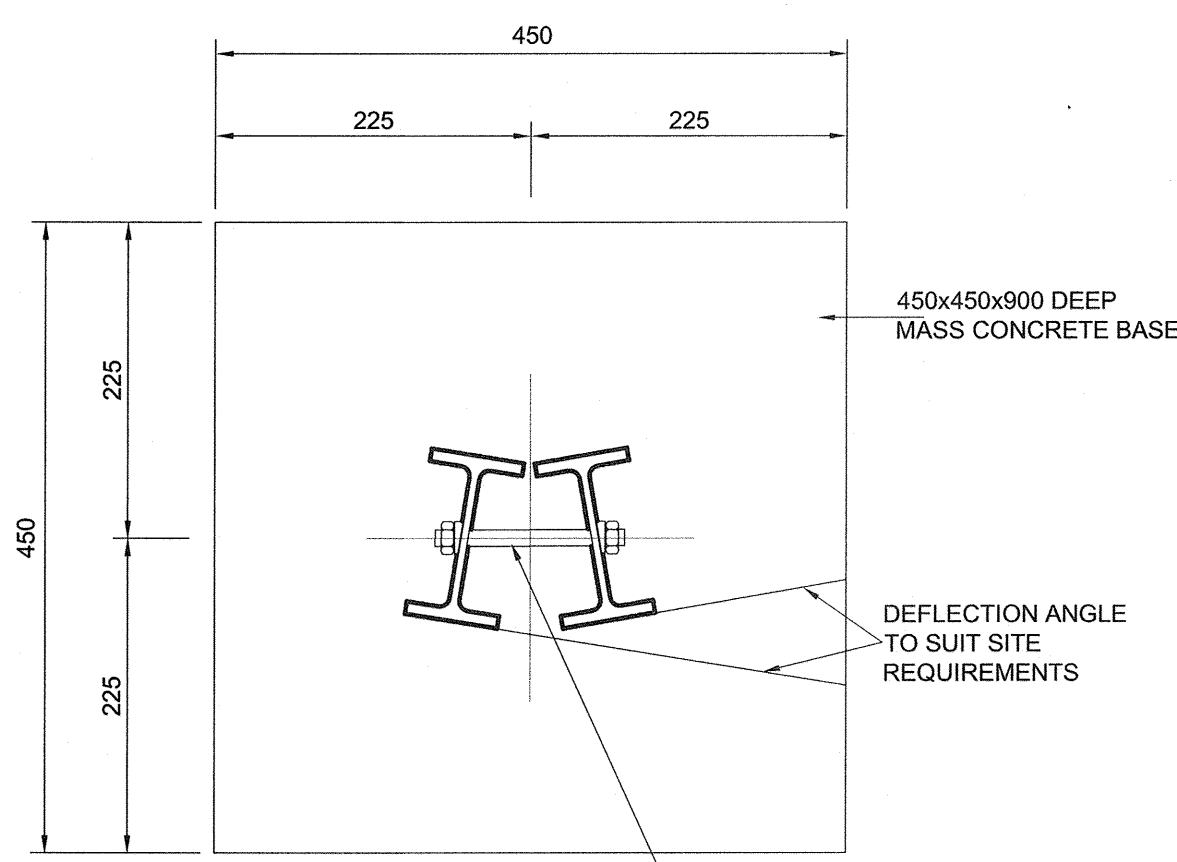

DETAIL OF MASS CONCRETE BASE WITH CHANGE OF DIRECTION TYPE "A2"
1:5

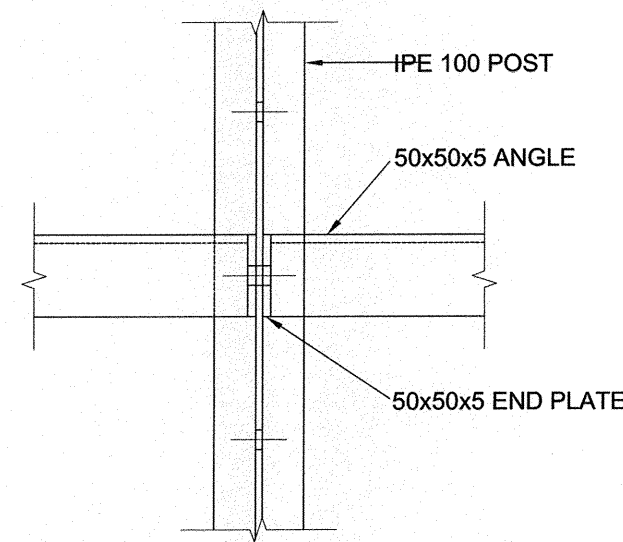

DETAIL 1
TYPICAL CONNECTION DETAIL
1:5

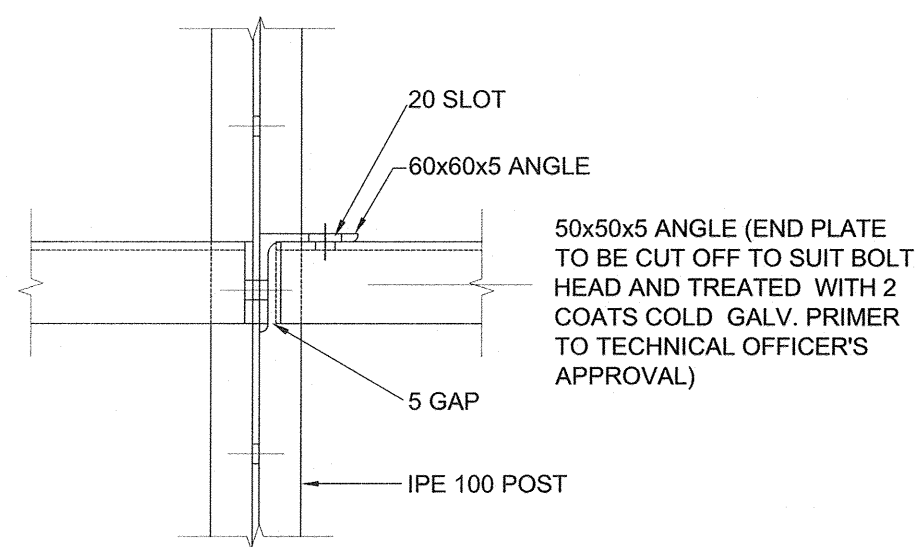

DETAIL 2
TYPICAL EXPANSION JOINT DETAIL
1:5

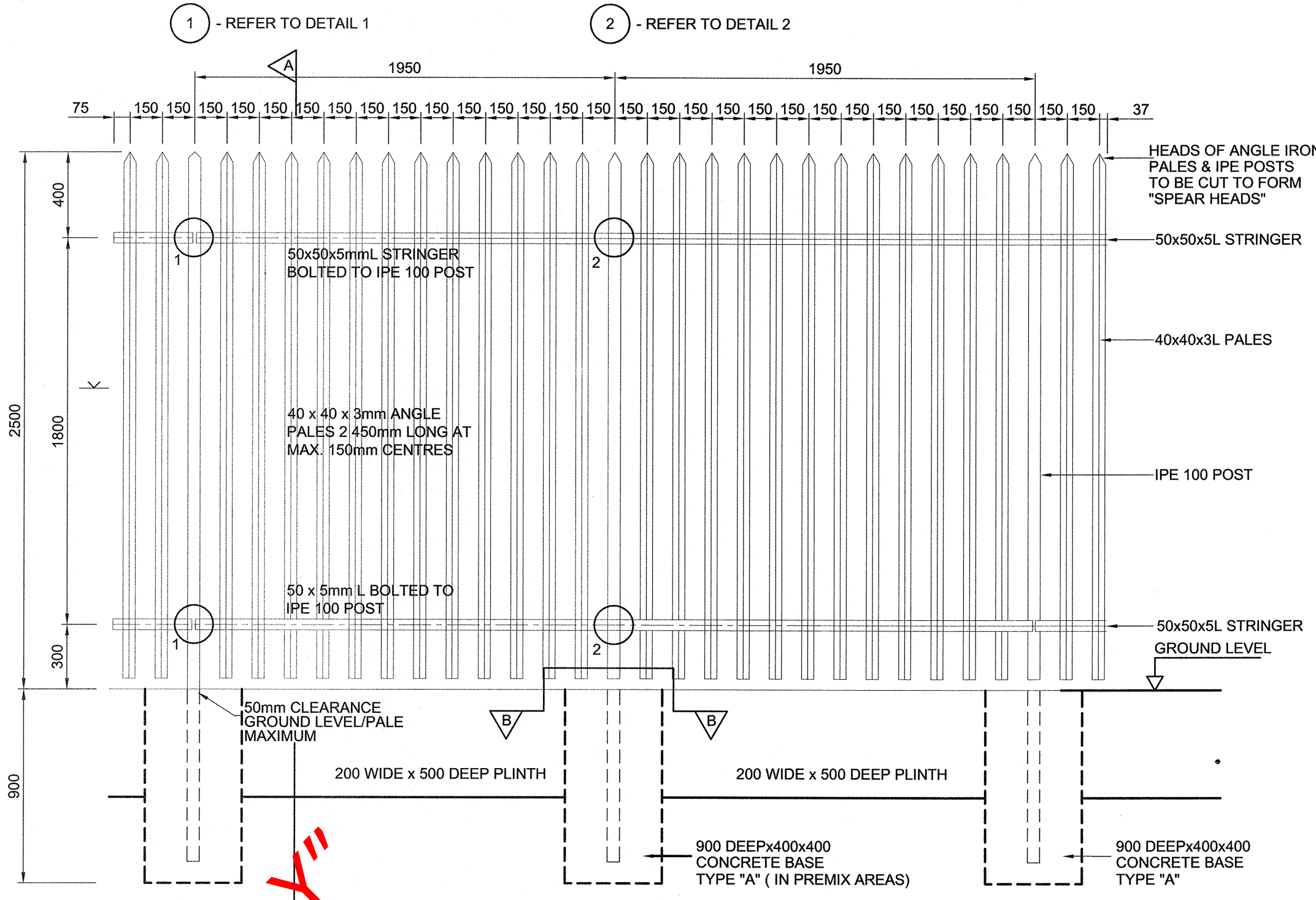

ELEVATION
1:20

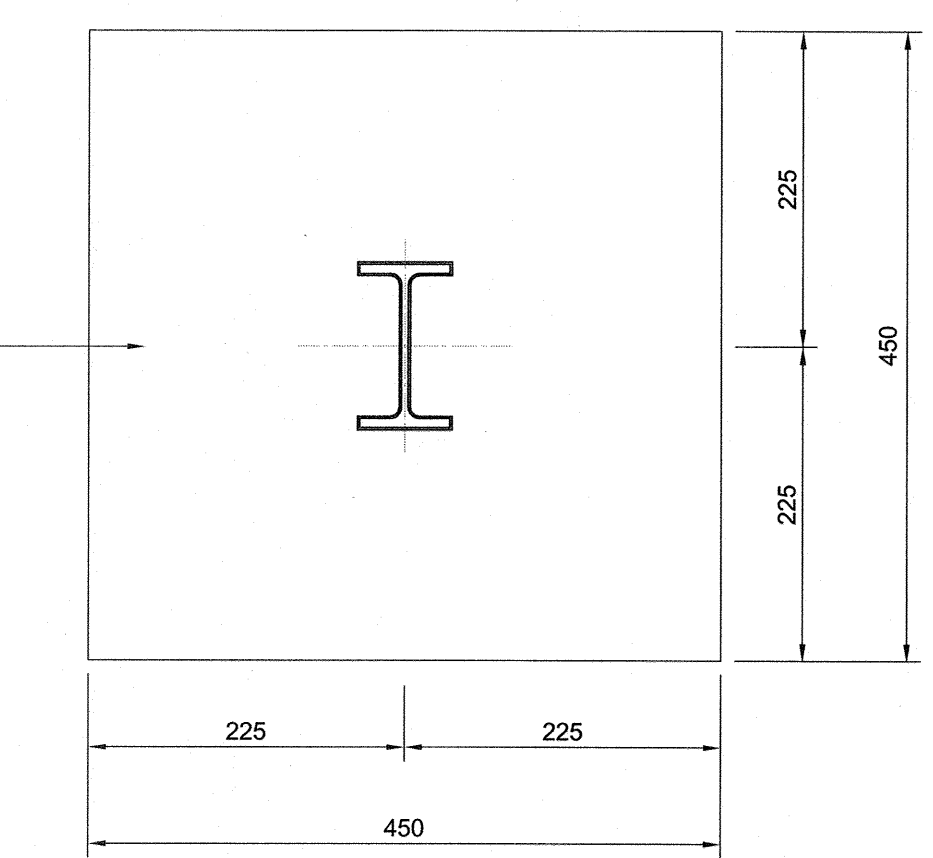

SECTIONAL PLAN B-B TYPE "A1"
1:5

"PREVIEW COPY ONLY"

- NOTES**
- SETTING OUT
 - THE CONTRACTOR IS TO SET THE FENCE OUT BY SURVEY INSTRUMENT AND AS DIRECTED BY THE TECHNICAL OFFICER ON SITE. MANUFACTURED LENGTH AND DISTANCES OF FENCE TO CONFORM TO THE ABOVE APPROVED SETTING OUT SURVEYED DIMENSIONS. NO CONCRETING OF THE POSTS WILL BE ALLOWED UNTIL THE ENTIRE FENCE IS SET OUT AND APPROVED BY THE TECHNICAL OFFICER.
 - A 20mm EXPANSION JOINT IN THE STEEL PANEL MUST BE ALLOWED FOR AT EVERY 6TH POST.
 - FOUNDATIONS
 - EXCAVATIONS TO BE DONE BY HAND.
 - ALL INSITU FOUNDING MATERIAL TO BE COMPACTED TO 93% MOD, AND INSPECTED BY THE TECHNICAL OFFICER PRIOR TO POURING CONCRETE.
 - CONCRETE
 - ALL CONCRETE TO BE MIN. 25MPa AT 28 DAYS PFC CONTAINING NOT LESS THAN 40% BLASTFURNACE SLAG OR A 50/50 BLEND OF EITHER OPC OR PC15 AND BLASTFURNACE BLEND.
 - STEEL PANELS
 - STEEL TO BE HOT-DIPPED GALVANISED WITH MINIMUM ZINC COATING THICKNESS BEING 105 MICRONS (HEAVY DUTY GALVANISING). (ISO 1461)
 - ALL WELDS 6mm CONTINUOUS FILLET.
 - ALL FENCE BOLTS, WASHERS & NUTS TO BE GALVANISED. ALL BOLTS TO BE 10mm DIA. ALL NUTS TO HAVE A SPECIAL BREAK OFF FACILITY FOR SECURITY MEASURES: ANCHOR BOLTS TO BE Ø24 STAINLESS STEEL WITH MIN EFFECTIVE 190mm ANCHOR DEPTH HILT- HIT- RE 500HAS- M24X215 OR SIMILAR APPROVED
 - NO CUTTING OF STEEL OR WELDING ON SITE WILL BE ALLOWED WITHOUT PRIOR APPROVAL FROM THE TECHNICAL OFFICER.
 - CONTRACTOR TO CALCULATE ALL CUTTING DIMENSIONS AND TO PRODUCE SHOP DETAILS FOR APPROVAL BY THE TECHNICAL OFFICER PRIOR TO FABRICATION. FENCE POSTS ALLOW FOR STEPS IN INCREMENTS OF 100mm
 - WHERE 100mm VERTICAL STEPS ARE REQUIRED, 100mm IS TO BE CUT OFF THE BOTTOM OF THE FIRST POST AND PROTECTED WITH 2 COATS COLD GALVANIZING.
 - ALL COLD GALVANIZING TO BE DONE WITH ZINCFIX AS SUPPLIED BY HOT DIP GALVANIZING ASSOCIATION OF SOUTH AFRICA.
 - 3x Ø12 POST HOLES TO TAKE HORIZONTAL BOTTOM ONLY STRINGER TO BE MANUFACTURED WITH 35mm VERTICAL SLOTS

DRAWING NO.	REFERENCE

NOTES

- DO NOT SCALE DRAWING - ONLY DIMENSIONS SHOWN TO BE USED.
- THE CONTRACTOR SHALL VERIFY ALL CONDITIONS, DIMENSIONS AND LEVELS ON THE SITE AND NOTIFY THE NEC SUPERVISOR OF ANY VARIATIONS BEFORE CONSTRUCTION.

REVISIONS	
NO.	DESCRIPTION
0A	ISSUED FOR TENDER

CONTRACTOR / CONSULTANT				TRANSNET CAPITAL PROJECTS			
TITLE	NAME	SIGN	DATE	TITLE	NAME	SIGN	DATE
				DRAWN	LM	[Signature]	14 09 11
				CHECKED	MM	[Signature]	14 09 11
				DESIGNED			
				CHECKED			
OPERATING DIVISIONS				PR.ENG. / PR.TECH./PR. ARCH			
TITLE	NAME	SIGN	DATE	TITLE	NAME	SIGN	DATE

Transnet Capital Projects
TRANSNET LTD (TRADING AS TRANSNET CAPITAL PROJECTS) - REG. NO. 199500090006
 237 MAHATMA GANDHI ROAD
 DURBAN TEL: 031 361 1696
 P.O. BOX 1073, DURBAN FAX: 0866 770615

PORT OF RICHARDS BAY
 TRANSNET NATIONAL PORT AUTHORITY

PALISADE FENCE DETAILS

PROJECT NUMBER: A141229601001CDE
 DRAWING NO.: 0002010A
 SHEET: 01
 REV: 0
 ID: TD

1 2 3 4 5 6 7 8



Transnet SOC Limited
Transnet RME

REQUEST FOR QUOTATION

BOARD LIST TFR RME
TRANSNET FREIGHT RAIL - RME
PROCUREMENT DEPARTMENT
2000

Registration Number: 1990/000900/30
Vat Number : 4720103177

Attention:

Telephone Number :
Fax Number :
Vendor Number :2004815

Quotation Deadline Date : 23.09.2015
Quotation Deadline Time : 12:00

REQUEST for QUOTATION
Transnet RME
RFQ Number / Date
6000234692 / 11.09.2015
Contact Person / Telephone
Mari Maritz / 035 906 7348
Return to FAX Number/EMAIL
0865 65997 / TCPtendersRichardsBay@Transnet.net

Item	Material	Description	RFQ Qty	UoM	Required Del date	Confirm Del date	Unit Price Excl	Total Price Excl
00010		Supply and install Bayv	1		30.09.2015			

Supply and install Bayview sliding gate motor with 25 sensors, anti-theft bracket, padlock and wireless safety beams. (New railing will be installed by Transnet)

Transnet Limited t/a Transnet Freight Rail RME # Richards Bay, hereby invite your company to attend a compulsory site meeting to supply a detailed quotation to provide the following:

Supply and deliver gate motors

Notes:

1. Compulsory site meeting will be on the 18th of September 2015 at 10:00am at Transnet offices, Old Naval base, Commodores close, Meerensee, Richards Bay
2. The specifications or technical data sheet of the products offered should be submitted with the quotation; if not it will result in a bid being disqualified
3. Prices should include delivery to the Port Richards Bay
4. Refer to the attached specification of Goods

All technical queries relating to this request may be addressed to: Sbu Luvuno - 035 905 4607 / 073 043 3265 or Lindelwa Majenge - 060 539 6638. All procurement relating queries can be addressed to the Mari Maritz - 035 906 7348.

The closing time for receipt of your official quotations is: 12:00 hrs on Wednesday, the 23rd of September 2015.



Transnet SOC Limited
Transnet RME
 BOARD LIST TFR RME
 TRANSNET FREIGHT RAIL - RME
 PROCUREMENT DEPARTMENT
 2000
 YOUR VAT NUMBER WITH US: NOT

REQUEST FOR QUOTATION

Registration Number: 1990/000900/30
Vat Number : 4720103177

Attention:
 Telephone Number :
 Fax Number :
 Vendor Number :2004815

Quotation Deadline Date : 23.09.2015
Quotation Deadline Time : 12:00

REQUEST for QUOTATION
 Transnet RME
RFQ Number / Date
 6000234692 / 11.09.2015
Contact Person / Telephone
 Mari Maritz / 035 906 7348
Return to FAX Number/EMAIL
 0865 5997 / TCPtendersRichardsBay@Transnet.net

Item	Material	Description	RFQ Qty	UoM	Required Del date	Confirm Del date	Unit Price Excl	Total Price Excl
------	----------	-------------	---------	-----	-------------------	------------------	-----------------	------------------

Telephonic and late quotes will not be accepted. All quotations should be submitted via fax to 086 515 9978 or alternatively e-mailed to tcpptendersrichardsbay@transnet.net

Procurement Official - Attention: Futhi Sefehle

Identification details:

Quotation / Reference number: ERAC-RCB-19303-MM-015

Description: Supply and deliver gate motors

The supplier's/ contractor's address and identification details have to be shown on each quotation received.

a) Respondents are required to submit with their Quotations the following Returnable Documents, as detailed below:

1. The specifications or technical data sheet of the products offered should be submitted; if not it will result in a bid being disqualified
2. Valid Tax Clearance certificate.
3. Copy of your latest B.B.B.E.E. Certificate

Failure to provide the above mentioned Returnable Documents at the Closing Date and time of this RFQ could result in a Respondent's bid being disqualified.

Notes:

1. #Transnet may not necessarily accept the lowest or any other offer and reserves the right to select in its favor any or, a portion of any offer made". If you are unable to quote for this survey, please submit a NO QUOTE, with a short reasons, if possible, for not being able to quote. Otherwise we look forward to receive your quote by the date and time stated.
2. The "preview copy only" posted on Transnet's website are not allowed to be priced on. The original copy needs to be requested from Transnet to be recorded on a collection register. Should pricing be received on a "preview copy only" document or if the original copy was not requested from Transnet, it will result in a bid being disqualified



Transnet SOC Limited
 Transnet RME
 BOARD LIST TFR RME
 TRANSNET FREIGHT RAIL - RME
 PROCUREMENT DEPARTMENT
 2000
 YOUR VAT NUMBER WITH US: NOT

REQUEST FOR QUOTATION

Registration Number: 1990/000900/30
 Vat Number : 4720103177

Attention:
 Telephone Number :
 Fax Number :
 Vendor Number :2004815

Quotation Deadline Date : 23.09.2015
Quotation Deadline Time : 12:00

REQUEST for QUOTATION
 Transnet RME
RFQ Number / Date
 6000234692 / 11.09.2015
Contact Person / Telephone
 Mari Maritz / 055 906 7348
Return to FAX Number/EMAIL
 0865 5997 / TCPtendersRichardsBay@Transnet.net

Item	Material	Description	RFQ Qty	UoM	Required Del date	Confirm Del date	Unit Price Excl	Total Price Excl
Delivery address: Port of Richards Bay								
00020		Supply and install Pion	1	ea	30.09.2015			
Supply and install Pioneer centre sliding gate motor with 40 remotes, anti-theft bracket padlock and wireless safety beams, (Power point will be supplied at the gate by Transnet)								
00030		Supply and install stor	1	ea	30.09.2015			
Supply and install Store swing gate motor, with 10 remotes and wireless safety beams (Power point will be supplied at the gate by Transnet)								
00040		Supply and install CCTV	1	ea	30.09.2015			
Supply and install CCTV control room swing gate motor with 15 remotes and wireless safety beams. (Power point will be supplied at the gate by Transnet)								

PREVIEW COPY



Transnet SOC Limited
Transnet RME
 BOARD LIST TFR RME
 TRANSNET FREIGHT RAIL - RME
 PROCUREMENT DEPARTMENT
 2000
 YOUR VAT NUMBER WITH US: NOT

REQUEST FOR QUOTATION

Registration Number: 1990/000900/30
Vat Number : 4720103177

Attention:
 Telephone Number :
 Fax Number :
 Vendor Number : 2004815

Quotation Deadline Date : 23.09.2015
Quotation Deadline Time : 12:00

REQUEST for QUOTATION
 Transnet RME
RFQ Number / Date
 6000234692 / 11.09.2015
Contact Person / Telephone
 Mari Maritz / 053 906 7348
Return to FAX Number/EMAIL
 0865 5997 / TCPtendersRichardsBay@Transnet.net

Delivery Address

TFR RME Richards Bay
 Old Naval Base, Commodores Clo
 Meerensee, Richards Bay
 3900

This RFQ is subject to the following conditions:

1. Price/s : The price/s quoted in SA currency and is excluding of V.A.T.
2. Delivery : The price/s quoted should include delivery cost to the delivery address stated on the RFQ
3. Returnables : A valid tax clearance certificate and BBBEE certificate from a SANAS accredited verification agency attached to quotation for all quotes above R30 000.
 Please note that only the official Transnet RFQ will be accepted and all other correspondence to be attached to the original
4. Safety : To confirm to Transnet Freight Rail RME Health & Safety plan and specification; HAS-std-0001, copy available on request.
5. Confirmation: To confirm your participation in this tender process please sign and return this document as immediate effect prior to the quotation deadline.
6. Negotiations: The Employer may elect to negotiate the final terms of the contract/order with the preferred tenderer in accordance with Clauses F.2.17 and F.3.13 of the CIDB Standard Conditions of Tender. A copy of which is available upon request.
7. Quotes will not be acceptable if not sending to the given fax or e-mail (please do not CC any buyer)
8. Should your company not receive any response from Transnet within 30 days of closing of a RFQ, please accept that your quotation was unsuccessful.

 Signature

 Date

PRELIMINARY COPY