



Transnet SOC Limited
Transnet RME

REQUEST FOR QUOTATION

BOARD LIST TFR RME
TRANSNET FREIGHT RAIL - RME
PROCUREMENT DEPARTMENT
2000

Registration Number: 1990/000900/30
Vat Number : 4720103177

Attention:
TFR Tender Board.
Telephone Number :
Fax Number :
Vendor Number :2004815

Quotation Deadline Date : 26.05.2015
Quotation Deadline Time : 12:00

REQUEST for QUOTATION
Transnet RME
RFQ Number / Date
6000225558 / 15.05.2015
Contact Person / Telephone
Eddie Quinn / 035 906 7347
Return to VAX Number/EMAIL
0865159978 / TCPtendersRichardsBay@Transnet.net

"PREVIEW COPY ONLY"

Item	Material	Description	RFQ Qty	UoM	Required Del date	Confirm Del date	Unit Price Excl	Total Price Excl
00010		Clamp Assembly purpose	50	ea	01.07.2015			
Supply & Deliver, 50 x Complete H.D. Galv. Cantilever Clamp Assemblies, as per the attached Drawing No: CEE-TNB-4, Sheets: 1 & 2. Delivered to: 1 Morris Road - Empangeni Rail - Old Goods Shed. Contact: Mr Pierre Crocker Tel: 035-905 3638 / 083 279 0437.								
00020		Wedge Block only as per	30	ea	01.07.2015			
Supply & Deliver, 30 x H.D. Galv. Wedge Blocks, as per the attached Drawing No: CEE-TX-85. Delivered to: 1 Morris Road - Empangeni Rail - Old Goods Shed. Contact: Mr Pierre Crocker Tel: 035-905 3638 / 083 279 0437.								
00030		Wedge Block only as per	30	ea	01.07.2015			
Supply & Deliver, 30 x H.D. Galv. Wedge Blocks, as per the attached Drawing No: CEE-TX-86.								



Transnet SOC Limited
 Transnet RME
 BOARD LIST TFR RME
 TRANSNET FREIGHT RAIL - RME
 PROCUREMENT DEPARTMENT
 2000
 YOUR VAT NUMBER WITH US: NOT

REQUEST FOR QUOTATION

Registration Number: 1990/000900/30
 Vat Number : 4720103177

Attention:
 TFR Tender Board.
 Telephone Number :
 Fax Number :
 Vendor Number :2004815

Quotation Deadline Date : 26.05.2015
Quotation Deadline Time : 12:00

REQUEST for QUOTATION
 Transnet RME
RFQ Number / Date
 6000225558 / 15.05.2015
Contact Person / Telephone
 Eddie Quinn / 035 906 7347
Return to VAX Number/EMAIL
 0865159978 / TCPtendersRichardsBay@Transnet.net

Item	Material	Description	RFQ Qty	UoM	Required Del date	Confirm Del date	Unit Price Excl	Total Price Excl
------	----------	-------------	---------	-----	-------------------	------------------	-----------------	------------------

Delivered to: 1 Morris Road - Empangeni Rail - Old Goods Shed.
 Contact: Mr Pierre Crocker Tel: 035-905 3638 / 083 279 0437.

Transnet Limited t/a Transnet Freight Rail (R.M.E.) # Richards Bay, hereby invite your company to submit a detailed quotation for:

The Supply & Delivery of Various H.D. Galv. Cantilever Clamping Items. (As requested above.)

All technical queries relating to this invitation may be addressed to;
 Mr. Pierre Crocker Tel: 083 279 0437 / 035-905 3638.

All tender related queries pertaining to this invitation may be addressed to;
 Mr. Eddie Quinn, Tel: 035 # 905 3664.

The closing time for receipt of your official quotations is 12:00 hours on Thursday, 26 May 2015.

Transnet desires a validity period of 90 (Ninety) days from the closing date of this RFQ.

Telephonic, Hand delivered and Late quotes will not be accepted.
 All quotations should be clearly marked, and may be faxed or e-mailed to:
 Miss Yogeshnie Gengan, Tender & Fax Assistant,
 Fax No: 086 515 9978 and / or
 e-mailed to: TCPtendersRichardsBay@transnet.net

"PREVIEW COPY ONLY"



Transnet SOC Limited
 Transnet RME
 BOARD LIST TFR RME
 TRANSNET FREIGHT RAIL - RME
 PROCUREMENT DEPARTMENT
 2000
 YOUR VAT NUMBER WITH US: NOT

REQUEST FOR QUOTATION

Registration Number: 1990/000900/30
 Vat Number : 4720103177

Attention:
 TFR Tender Board.
 Telephone Number :
 Fax Number :
 Vendor Number : 2004815

Quotation Deadline Date : 26.05.2015
Quotation Deadline Time : 12:00

REQUEST for QUOTATION
 Transnet RME
RFQ Number / Date
 6000225558 / 15.05.2015
Contact Person / Telephone
 Eddie Quinn / 035 906 7347
Return to VAX Number/EMAIL
 0865159978 / TCPtendersRichardsBay@Transnet.net

Item	Material	Description	RFQ Qty	UoM	Required Del date	Confirm Del date	Unit Price Excl	Total Price Excl
------	----------	-------------	---------	-----	-------------------	------------------	-----------------	------------------

N.B.

The contractor's address and identification details have to be shown on each quotation submitted.

- Please submit the following documents with your quotation;
- Valid Tax Clearance certificate.
 - Copy of your latest B.B.B.E.E. Certificate.

Failing to submit any of the documents mentioned above, could result in your quotation to be disqualified / not accepted.

Note: #Transnet may not necessarily accept the lowest or any other offer and reserves the right to select in its favor any or, a portion of any offer made"

If you have been contacted directly by the Supply Chain Office (Via a RFQ.), and you are unable to quote for these items, please submit a NO QUOTE.

Otherwise we look forward to receive your detailed quote by the date and time stated.

Yours faithfully,

PREVIEW COPY ONLY



REQUEST FOR QUOTATION

Transnet SOC Limited
 Transnet RME
 BOARD LIST TFR RME
 TRANSNET FREIGHT RAIL - RME
 PROCUREMENT DEPARTMENT
 2000
 YOUR VAT NUMBER WITH US: NOT

Registration Number: 1990/000900/30
 Vat Number : 4720103177

Attention:
 TFR Tender Board.
 Telephone Number :
 Fax Number :
 Vendor Number :2004815

Quotation Deadline Date : 26.05.2015
Quotation Deadline Time : 12:00

REQUEST for QUOTATION
 Transnet RME
RFQ Number / Date
 6000225558 / 15.05.2015
Contact Person / Telephone
 Eddie Quinn / 035 906 7347
Return to VAX Number/EMAIL
 0865159978 / TCPtendersRichardsBay@Transnet.net

Delivery Address

TFR RME Richards Bay
 Old Naval Base, Commodores Clo
 Meerensee, Richards Bay
 3900

This RFQ is subject to the following conditions:

1. Price/s : The price/s quoted in SA currency and is excluding of V.A.T.
2. Delivery : The price/s quoted should include delivery cost to the delivery address stated on the RFQ
3. Returnables : A valid tax clearance certificate and BBEE certificate from a SANAS accredited verification agency attached to quotation for all quotes above R30 000.
Please note that only the official Transnet RFQ will be accepted and all other correspondence to be attached to the original
4. Safety : To confirm to Transnet Freight Rail RME Health & Safety plan and specification; HAS-std-0001, copy available on request.
5. Confirmation: To confirm your participation in this tender process please sign and return this document as immediate effect prior to the quotation deadline.
6. Negotiations: The Employer may elect to negotiate the final terms of the contract/order with the preferred tenderer in accordance with Clauses F.2.17 and F.3.13 of the CIDB Standard Conditions of Tender. A copy of which is available upon request.
7. Quotes will not be acceptable if not sending to the given fax or e-mail (please do not CC any buyer)
8. Should your company not receive any response from Transnet within 30 days of closing of a RFQ, please accept that your quotation was unsuccessful.

 Signature

 Date

REQ 10463646

ITEM	DESCRIPTION / BESKRYWING	QTY HVLD	STORES ITEM NO	DRG. NO. CEE. TEK	AMENDMENTS MYSIGINGS
1	CLAMP BODY KLAMPROMP	1	54/	TNB-4 SH VEL 2	NO NAME DATE
2	WEDGE BLOCK WIGBLK	1	54/	TX-85	6 6 Abraham 88-03-04
3	WEDGE BOLT WIGBOU	1		TX-86	REVISED, REDRAWN AND RENUMBERED. DRG NO WAS CEE-54/110238
4	SPRING WASHER M16 VEERWASTER M16	1			HERSTEN, OORGETEKEN EN HERNOMMER. TEK NO WAS CEE-54/110238
5	NUT, STEEL M16-7H MOER, STAAL M16-7H	1			DO REF T87/103 TK-VERW

7 J.V.T. 89-10-16
ITEM NOS (54/1039054/110241) REMOVED / VERWYDER.
D O REF T 89/005
TK-VERW

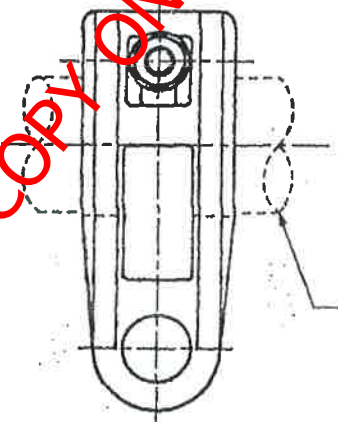
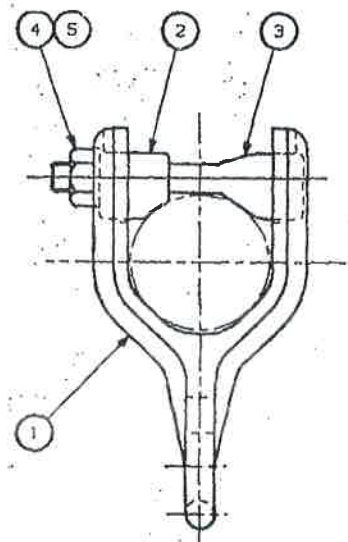

TUBULAR CANTILEVER ARM
BUISVORMIGE-VRYDRAERARM

"PREVIEW COPY ONLY"



DIMENSIONS, MILLIMETRES AFMETINGS, MILLIMETER		GEN TOLERANCES, LINES ALG TOLERANSIES, LINS/HOEK+	
DRN	SET	DO REF	ENG
TRCD	CAD	TK-VERW	IR
CKD		DATE 65/06/29	R. BARNES For
NGS		DATUM	DS.
CHIEF ELECTRICAL ENGINEER ELEKTRIESE HOOFINGENIEUR		JOHANNESBURG	
SOUTH AFRICAN TRANSPORT SERVICES SUID-AFRIKAANSE VERVOERDIENSTE			

ELECTRIFICATION TYPE: A, B & C
CLAMP ASSEMBLY-SINGLE PURPOSE
TUBULAR CANTILEVERS
ELEKTRIFIKASIE TIEPE: A, B & C
KLAMPSAMESTEL-EENDOELIG
BUISVORMIGE VRYDRAERS

ASSY DRG
SAMEST-TEK
ELECTRIFICATION TYPES
REFERENCE DRG NO
CEE-MA-26 SH 7B
ELEKTRIFIKASIE TIEPE
VERWYSINGSTEK-NO
CEE-MA-369 VEL 7B
STORES ITEM NO
MAGASYNITEM NO
54/4905
DRAWING NO CEE-
TEKENING TNB-4
SHEET 1 OF 2
VEL VAN 2

Req: 10463647

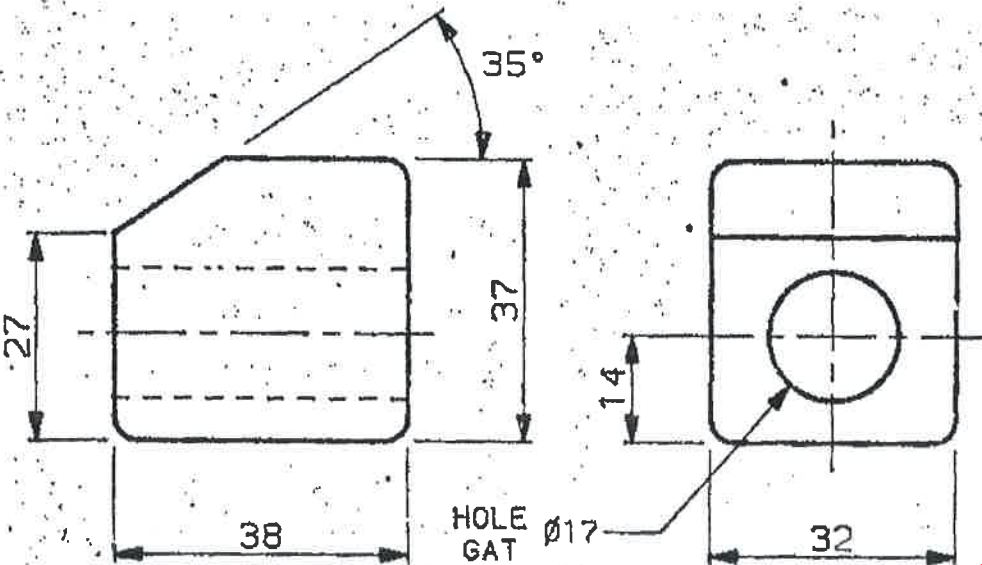

NOTES/OPMERKINGS

1. THIS ARTICLE MUST BE MANUFACTURED UNDER THE MARK OF THE SABS. HIERDIE ARTIKEL MOET VERVAARDIG WORD VOLGENS 'N PROSES WAT ONDER INSPEKSIE VAN DIE SABS STAAN.
2. THIS ARTICLE MUST BE ZINC COATED UNDER THE MARK OF THE SABS TO SPEC SABS 763 (H.D.G.). HIERDIE ARTIKEL MOET SINKBEDEK WORD VOLGENS 'N PROSES WAT ONDER INSPEKSIE VAN DIE SABS STAAN (SPES SABS 763) (H.D.G.).
3. ALL UNSPECIFIED RADII R3. ALLE ONGESPEFISEERDE RADIUSSE R3.

DIMENSIONS, MILLIMETRES
AFMETINGS, MILLIMETER

MATERIAL / MATERIAAL

MALLEABLE CAST IRON TO SABS 1190
BLACKHEART GRADE B340, WHITEHEART
GRADE W410 OR PEARLITIC GRADE P440
SMEEBARE GIETYSER VOLG. SABS 1190
SWARTKERN GRAAD B340, WITKERN GRAAD
W410 OF PERLITIES GRAAD P440



DRN _____	GEN TOL, LIN ± 1
GET _____	ALG TOL, ANG/HOEK ± 0°30'
TRCD _____	DO REF _____
NGT CAD	TK-VERW _____
CKD _____	DATE 55/03/18
NGS _____	DATUM _____

CHIEF ELECTRICAL ENGINEER
ELEKTRIESE HOOFINGENIEUR JOHANNESBURG

SOUTH AFRICAN TRANSPORT SERVICES
SUID-AFRIKAANSE VERVOERDIENSTE

WEDGE BLOCK
FOR CLAMP ON TUBULAR CANTILEVERS

WIGBLOK
VIR KLAMP AAN BUISVORMIGE VRYDRAERS

AMENDMENTS
WYSIGINGS

NO	NAME NAAM	DATE DATUM
2	GJA	88-3-A

REDRAWN AND RE-NUMBERED. DRG NO WAS CEE-TN-412 OORGETEKEN EN HERNOMMER. TEK NO WAS CEE-TN-412 DO REF T87/103 TK-VERW

3	J.V.T.	89-10-16
---	--------	----------

ITEM NO (54/11024) REMOVED / VERWYDER. DO REF T89/005 TK-VERW

CEE-TNB-5 SH/VEL 1
CEE-TNB-4 SH/VEL 1

ASSY DRG
SAMEST-TEK

STORES ITEM NO
MAGASYNITEM

DRG NO CEE-
TEK TX-85

SHEET 1 OF 1
VEL VAN 1

Rev: 10463648

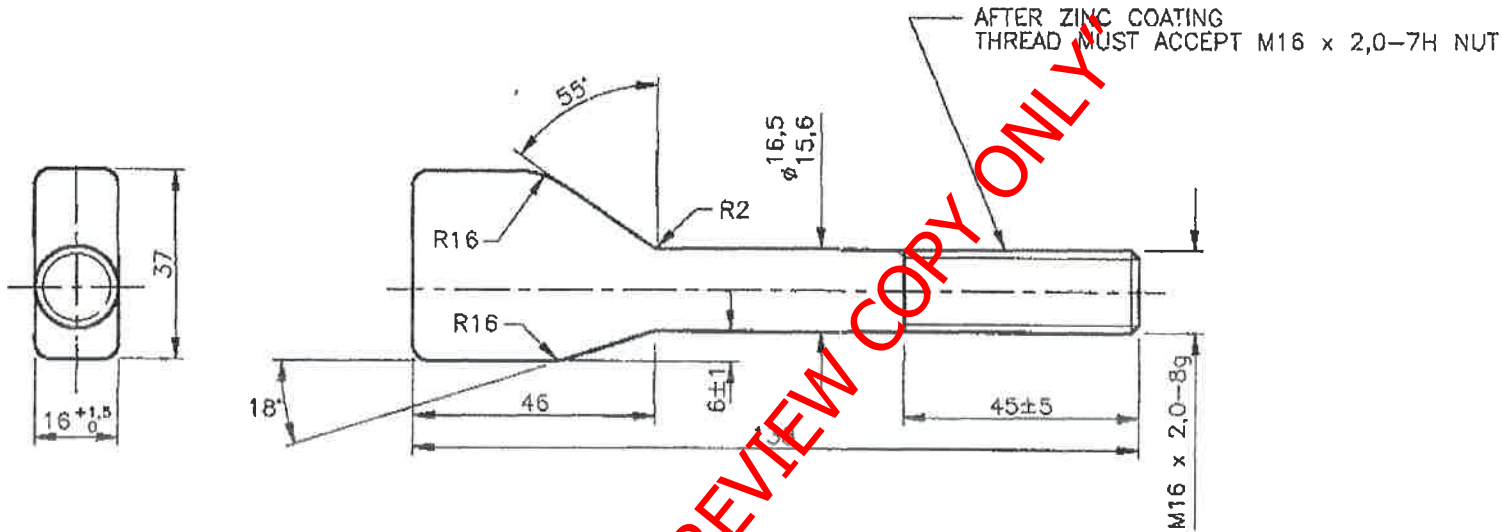

FINISH
ZINC COAT TO SPEC SABS 763 FOR CONDITIONS IN SITU.

(H.D.G.)

NOTE
ALL UNSPECIFIED RADII R3.

AMENDMENTS

NO	NAME	DATE
5	G ABRAHAM	88-03-04
REDRAWN AND RENUMBERED. DRG NO WAS CEE 54/110235 DO REF T87/103		
6	JP du P	96-02-07
REVISED, THREAD PITCH WAS 1,5. DO REF: T96/003		

MATERIAL: ITEM NO _____, STEEL TO BS 916		
DO REF: -	GEN TOL: LIN ± 1,5	ANG ± 0° 30'
DRN: -	CKD: -	DATE: 65-03-18
ENG: -	R BARNES for CHIEF ENG	

WEDGE BOLT
FOR CLAMP ON TUBULAR CANTILEVERS

INFRASTRUCTURE
(ELECTRICAL)



DIMENSIONS: mm
SCALE: 1:1



DRAWING NO CEE-
TX-86

SHEET - OF -

56600021