

TRANSNET



freight rail

A Division of Transnet SOC Limited Registration number 1990/00900/30

**REQUEST FOR
QUOTATION**

KBY/53130

"PREVIEW COPY ONLY"

Senior Buyer
Supply Chain Services
TRANSNET FREIGHT RAIL
Austen Street
KIMBERLEY
8301

Transnet Freight Rail, a division of

TRANSNET SOC LTD

Registration Number 1990/000900/30

[Hereinafter referred to as **Transnet**]

REQUEST FOR QUOTATION [RFQ] No KBY/53130

FOR THE AS WHEN REQUIRED, REPAIRS AND ERECTION OF FENCE FOR A PERIOD OF SIX (6) MONTHS.

**FOR DELIVERY TO : TRANSNET FREIGHT RAIL, VARIOUS SUBSTATIONS
AT INFRA KIMBERLEY NORTH DEPOT.**

ISSUE DATE : 07 AUGUST 2014

CLOSING DATE : 07 SEPTEMBER 2014

CLOSING TIME : 10:00

COMPULSORY INFORMATION MEETING DETAILS:

DATE : 19 AUGUST 2014

TIME : 11:00

**VENUE : TRANSNET FREIGHT RAIL, REAL ESTATE BUILDING
(FORMERLEY CALLED PROPERTY MANAGEMENT-
BUILDING), GROUND FLOOR BOARDROOM,
AUSTEN STREET, BEACONSFIELD, KIMBERLEY.**

N.B! Failure to attend a COMPULSORY information meeting will result in your bid being overlooked during the award process.

TENDER QUIRIES : Ms Refilwe Ramothwala Tel: 053 838 3309

DOCUMENT COLLECTION : Ms Leonie Visagie Tel: 053 838 3119

E-mail Leonie.Visagie@transnet.net

Section 1
NOTICE TO BIDDERS

Quotations which must be completed as indicated in Section 2 of this RFQ are to be submitted as follows:

METHOD: [Tender box or courier]
CLOSING VENUE: [Tender box at physical address for hand delivery and courier:
 Transnet Freight Rail, Real Estate Building (Formerly known as Property Management Building), Supply Chain Services, Office no. 2, Austen Street, Beaconsfield]

1 Responses to RFQ

Responses to this RFQ [Quotations] must not include documents or reference relating to any other quotation or proposal. Any additional conditions must be embodied in an accompanying letter.

2 Broad-Based Black Economic Empowerment [B-BBEE]

Transnet fully endorses and supports the Government's Broad-Based Black Economic Empowerment Programme and it would therefore prefer to do business with local business enterprises who share these same values. Transnet will accordingly allow a "preference" to companies who provide a valid B-BBEE Verification Certificate. All procurement transactions will be evaluated accordingly.

2.1 B-BBEE Scorecard and Rating

As prescribed in terms of the Preferential Procurement Policy Framework Act (PPPFA), Act 5 of 2000 and its Regulations, Respondents are to note that the following preference point system is applicable to all bids:

- The 80/20 system for requirements with a Rand value of up to R1 000 000.00 (all applicable taxes included).
- Bidders are to note that if the 80/20 preference point system is stipulated in this RFQ and all Bids received exceed R1 000 000.00, the RFQ must be cancelled.

The value of this bid is estimated to be below R1000 000.00 (all applicable taxes included) and therefore the **80/20** system shall be applicable.

When Transnet invites prospective suppliers to submit Proposals for its various expenditure programmes, it requires Respondents to have their B-BBEE status verified in compliance with the Codes of Good Practice issued in terms of the Broad Based Black Economic Empowerment Act No. 53 of 2003.

The Department of Trade and Industry recently revised the Codes of Good Practice on 11 October 2013 [Government Gazette No. 36928]. The Revised Codes will replace the Black Economic Empowerment Codes of Good Practice issued on 9 February 2007. The Revised Codes provide for a one year transitional period starting 11 October 2013. During the transitional period, companies may elect to be measured in terms of the Revised Codes or the 2007 version of the Codes. After the first year of the implementation of the Revised Codes, B-BBEE compliance will be measured in terms of the Revised Codes without any discretion. Companies which are governed by Sector-specific Codes will be measured in terms of those Sector Codes.

As such, Transnet will accept B-BBEE certificates issued based on the Revised Codes. Transnet will also continue to accept B-BBEE certificates issued in terms of the 2007 version of the Codes provided it was issued before 10 October 2014. Thereafter, Transnet will only accept B-BBEE certificates issued based on the Revised Codes.

Respondents are required to complete Annexure A [the B-BBEE Reference Point Claim Form] and submit it together with proof of their B-BBEE Status as stipulated in the Claim Form in order to obtain preference points for their B-BBEE status.

Note: Failure to submit a valid and original B-BBEE certificate or a certified copy thereof at the Closing Date of this RFQ will result in a score of zero being allocated for B-BBEE.

[Refer clause 19 below for Returnable Documents required]

2.2 B-BBEE Improvement Plan

Transnet encourages its Suppliers/Service Providers to constantly strive to improve their B-BBEE rating. Whereas Respondents will be allocated points in terms of a preference point system based on its B-BBEE scorecard to be assessed as detailed in paragraph 2.1 above, in addition to such scoring, Transnet also requests that Respondents submit a B-BBEE improvement plan. Respondents are therefore requested to indicate the extent to which they will maintain or improve their B-BBEE status over the contract period.

Respondents are requested to submit their B-BBEE Improvement Plan as an additional document with their Proposals by completion of **Annexure A** appended hereto. *[Refer to Annexure A for further instructions]*

Guidance Notes

- Note that for low value transactions, opportunities for B-BBEE Improvement are limited. Focus should be placed on longer term contracts.

3 Communication

- a) Respondents are warned that a response will be liable for disqualification should any attempt be made by a Respondent either directly or indirectly to canvass any officer(s) or employee of Transnet in respect of this RFQ between the closing date and the date of the award of the business.
- b) A Respondent may, however, before the closing date and time, direct any written enquiries relating to the RFQ to the following Transnet employee:

Name: Refilwe Ramothwala Email: Refilwe.Ramothwala@transnet.net

- c) Respondents may also, at any time after the closing date of the RFQ, communicate with Maggie Pain on any matter relating to its RFQ response:

Telephone 053 838 3341 Email Maggie.Pain@transnet.net

The Respondent's original and valid Tax Clearance Certificate must accompany the Quotation. Note that no business shall be awarded to any Respondent whose tax matters have not been declared by SARS to be in order.

4 VAT Registration

The valid VAT registration number must be stated here: _____ [if applicable].

5 Legal Compliance

The successful Respondent shall be in full and complete compliance with any and all applicable national and local laws and regulations.

6 Changes to Quotations

Changes by the Respondent to its submission will not be considered after the closing date and time.

7 Pricing

All prices must be quoted in South African Rand on a fixed price basis, excluding VAT.

8 Prices Subject to Confirmation

Prices quoted which are subject to confirmation will not be considered.

9 Negotiations

Transnet reserves the right to undertake post-tender negotiations with selected Respondents or any number of short-listed Respondents.

10 Binding Offer

Any Quotation furnished pursuant to this Request shall be deemed to be an offer. Any exceptions to this statement must be clearly and specifically indicated.

11 Disclaimers

Transnet is not committed to any course of action as a result of its issuance of this RFQ and/or its receipt of a Quotation in response to it. Please note that Transnet reserves the right to:

- modify the RFQ's goods / service(s) and request Respondents to re-bid on any changes;
- reject any Quotation which does not conform to instructions and specifications which are detailed herein;
- disqualify Quotations submitted after the stated submission deadline;
- not necessarily accept the lowest priced Quotation;
- reject all Quotations, if it so decides;
- place an order in connection with this Quotation at any time after the RFQ's closing date;
- award only a portion of the proposed goods / service/s which are reflected in the scope of this RFQ;
- split the award of the order/s between more than one Supplier/Service Provider; or

- make no award at all.

12 Transnet’s supplier integrity pact

Transnet’s Integrity Pact requires a commitment from suppliers and Transnet that they will not engage in any corrupt and fraudulent practices, anti-competitive practices; and act in bad faith towards each other. The Integrity Pact also serves to communicate Transnet’s Gift Policy as well as the remedies available to Transnet where a Respondent contravenes any provision of the Integrity Pact.

Respondents are required to familiarise themselves with the contents of the Integrity Pact which is available on the Transnet Internet site [www.transnet.net/Tenders/Pages/default.aspx] or on request. Furthermore, Respondents are required to certify that they have acquainted themselves with all the documentation comprising the Transnet Integrity Pact and that they fully comply with all the terms and conditions stipulated in the Transnet Supplier Integrity Pact as follows:

| | | | |
|------------|--|-----------|--|
| YES | | NO | |
|------------|--|-----------|--|

Should a Respondent need to declare previous transgressions or a serious breach of law in the preceding 5 years as required by Annexure A to the Integrity Pact, such declaration must accompany the Respondent’s bid submission.

13 Respondent’s Samples

Respondents are required to submit samples of the Goods tendered for by it **only in cases where Transnet has specifically requested samples**. The sample(s) must be endorsed with the RFQ number and description and forwarded on or before the deadline date to the following addressee:

N/A

14 Evaluation Criteria

Transnet will utilise the following criteria [not necessarily in this order] in choosing a Supplier/Service Provider, if so required:

| Criterion/Criteria | Explanation |
|--|--|
| Administrative responsiveness | Completeness of response and returnable documents |
| Substantive responsiveness | Prequalification criteria, if any, must be met and whether the Bid materially complies with the scope and/or specification given |
| Final weighted evaluation based on 80/20 preference point system as | <ul style="list-style-type: none"> • Pricing and price basis [firm] - whilst not the sole factor for consideration, competitive pricing and overall level of unconditional discounts¹ will be critical • B-BBEE status of company - Preference points will be awarded to a bidder for attaining the B-BBEE status level of contribution in accordance with the table indicated in Annexure A. |

¹ Only unconditional discounts will be taken into account during evaluation. A discount which has been offered conditionally will, despite not being taken into account for evaluation purposes, be implemented when payment is effected.

| | |
|-----------------------------------|--|
| indicated in paragraph 2.1 | |
|-----------------------------------|--|

15 Validity Period

Transnet desires a validity period of 30 [thirty] days from the closing date of this RFQ.
This RFQ is valid until _____.

16 Banking Details

BANK: _____
BRANCH NAME / CODE: _____
ACCOUNT HOLDER: _____
ACCOUNT NUMBER: _____

17 Company Registration

Registration number of company / C.C. _____
Registered name of company / C.C. _____

18 Disclosure of Prices Quoted

Respondents must indicate here whether Transnet may disclose their quoted prices and conditions to other Respondents:

YES NO

19 Returnable Documents

Returnable Documents means all the documents, Sections and Annexures, as listed in the tables below.

a) Respondents are required to submit with their Quotations the **Returnable Documents**, as detailed below.

Failure to provide all these Returnable Documents at the Closing Date and time of this RFQ may result in a Respondent's disqualification. Respondents are therefore urged to ensure that all these Documents are returned with their Quotations.

All Sections, as indicated in the footer of each page, must be signed, stamped and dated by the Respondent. Please confirm submission of these Returnable Documents by so indicating [Yes or No] in the table below:

Respondent's Signature

b

Date & Company Stamp

| Returnable Documents | Submitted [Yes or No] |
|---|--------------------------|
| SECTION 1 : Notice to Bidders | |
| <ul style="list-style-type: none"> - Valid and original B-BBEE Verification Certificate or certified copy thereof [Large Enterprises and QSEs] Note: failure to provide a valid B-BBEE Verification Certificate at the closing date and time of the RFQ will result in an automatic score of zero for preference | |
| <ul style="list-style-type: none"> - Valid and original B-BBEE certificate/sworn affidavit or certified copy thereof from auditor, accounting officer or SANAS accredited Verification Agency [EMEs] Note: failure to provide a valid B-BBEE Verification Certificate at the closing date and time of the RFQ will result in an automatic score of zero being allocated for preference | |
| <ul style="list-style-type: none"> - In the case of Joint Ventures, a copy of the Joint Venture Agreement or written confirmation of the intention to enter into a Joint Venture Agreement | |
| <ul style="list-style-type: none"> - Original valid Tax Clearance Certificate [Consortia / Joint Ventures must submit a separate Tax Clearance Certificate for each party] | |
| SECTION 2 : Quotation Form | |
| SECTION 3: Vendor Application Form | |
| <ul style="list-style-type: none"> • Original cancelled cheque or bank verification of banking details • Certified copies of IDs of shareholder/directors/members [as applicable] • Certified copies of the relevant company registration documents from Companies and Intellectual Property Commission (CIPC) • Certified copies of the company's shareholding/director's portfolio • Entity's letterhead • Certified copy of VAT Registration Certificate [RSA entities only] • Certified copy of valid Company Registration Certificate [if applicable] | |
| Financial Statements signed by your Accounting Officer or Audited Financial Statements for previous 3 years | |
| ANNEXURE A – B-BBEE Preference Points Claim Form | |

b) In addition to the requirements of paragraph a) above, Respondents are further requested to submit with their Proposals the following **additional documents** as detailed below.

Please confirm submission of these additional documents by so indicating [Yes or No] in the table below:

| Additional Documents | SUBMITTED [Yes or No] |
|-------------------------------------|--------------------------|
| ANNEXURE B: B-BBEE Improvement Plan | |

Section 2
QUOTATION FORM

I/We _____
hereby offer to supply the goods/services at the prices quoted in the Price Schedule below, in accordance with the conditions related thereto.

I/We agree to be bound by those terms and conditions in:

- the Standard Terms and Conditions for the Supply of Goods or Services to Transnet [available on request]; and
- any other standard or special conditions mentioned and/or embodied in this Request for Quotation.

I/We accept that unless Transnet should otherwise decide and so inform me/us, this Quotation [and, if any, its covering letter and any subsequent exchange of correspondence], together with Transnet's acceptance thereof shall constitute a binding contract between Transnet and me/us.

I/We further agree that if, after I/we have been notified of the acceptance of my/our Quotation, I/we fail to deliver the said goods/service/s within the delivery lead-time quoted, Transnet may, without prejudice to any other legal remedy which it may have, cancel the order and recover from me/us any expenses

Price Schedule

I/We quote as follows for the goods required, on a "delivered nominated destination" basis, excluding VAT:

KINDLY REFER TO THE ATTACHED PRICING SCHEDULE:

Delivery Lead Time from date of purchase order: _____ [week]

Notes to Pricing:

- a) All Prices must be quoted in South African Rand, exclusive of VAT
- b) To facilitate like-for-like comparison bidders must submit pricing strictly in accordance with this price schedule and not utilise a different format. Deviation from this pricing schedule could result in a bid being disqualified.
- c) Please note that should you have offered a discounted price(s), Transnet will only consider such price discount(s) in the final evaluation stage if offered on an unconditional basis.

Section 3
VENDOR APPLICATION FORM

Respondents are to furnish the following documentation and complete the Vendor Application Form below:

1. **Original** cancelled cheque **OR** letter from the Respondent's bank verifying banking details [with bank stamp]
2. **Certified** copy of Identity Document(s) of Shareholders/Directors/Members [where applicable]
3. **Certified copies** of the relevant company registration documents from Companies and Intellectual Property Commission (CIPC)
4. **Certified copies** of the company's shareholding/director's portfolio
5. A letter on the company's letterhead confirm physical and postal addresses
6. **Original** valid SARS Tax Clearance Certificate
7. **Certified copy** of VAT Registration Certificate
8. **A valid and original** B-BBEE Verification Certificate / sworn affidavit **or certified copy** thereof meeting the requirements for B-BBEE compliance as per the B-BBEE Codes of Good Practice
9. **Certified copy** of valid C
10. Company Registration Certificate [if applicable]

"PREVIEW COPY ONLY"



| | | | | | | | |
|---|-------------------------|---------------|-------------------------------|---------------|---------------------|-----------------|--|
| Company Trading Name | | | | | | | |
| Company Registered Name | | | | | | | |
| Company Registration Number Or ID Number If A Sole Proprietor | | | | | | | |
| Form of entity | CC | Trust | Pty Ltd | Limited | Partnership | Sole Proprietor | |
| VAT number (if registered) | | | | | | | |
| Company Telephone Number | | | | | | | |
| Company Fax Number | | | | | | | |
| Company E-Mail Address | | | | | | | |
| Company Website Address | | | | | | | |
| Bank Name | | | | | Bank Account Number | | |
| Postal Address | | | | | | Code | |
| Physical Address | | | | | | Code | |
| Contact Person | | | | | | | |
| Designation | | | | | | | |
| Telephone | | | | | | | |
| Email | | | | | | | |
| Annual Turnover Range (Last Financial Year) | | < R5 million | R5-35 million | > R35 million | | | |
| Does Your Company Provide | | Products | Services | Both | | | |
| Area Of Delivery | | National | Provincial | Local | | | |
| Is Your Company A Public Or Private Entity | | Public | | Private | | | |
| Does Your Company Have A Tax Directive Or IRP30 Certificate | | Yes | | No | | | |
| Main Product Or Service Supplied (E.G.: Stationery/Consulting) | | | | | | | |
| BEE Ownership Details | | | | | | | |
| % Black Ownership | % Black women ownership | | % Disabled person/s ownership | | | | |
| Does your company have a BEE certificate | | Yes | | No | | | |
| What is your broad based BEE status (Level 1 to 9 / Unknown) | | | | | | | |
| How many personnel does the firm employ | | Permanent | | Part time | | | |
| Transnet Contact Person | | | | | | | |
| Contact number | | | | | | | |
| Transnet operating division | | | | | | | |
| Duly Authorised To Sign For And On Behalf Of Firm / Organisation | | | | | | | |
| Name | | Designation | | | | | |
| Signature | | Date | | | | | |
| Stamp And Signature Of Commissioner Of Oath | | | | | | | |
| Name | | Date | | | | | |
| Signature | | Telephone No. | | | | | |

DUPLICATE COPY ONLY

KIMBERLEY NORTH DEPOT
SPECIAL CONDITIONS OF CONTRACT AND SPECIFICATION
FOR AS AND WHEN CONTRACT FENCING
PART A : GENERAL

A1 SCOPE OF WORK

This contract covers the removing, repairing and erecting of new fence or other fencing as specified by Technical Officer. (North Depot) The necessary equipment and machinery to be supplied by Contractor.

Bloemfontein – Beaconsfield – Kamfersdam – Hotazel.
Beaconsfield – Transcape

A2 DURATION OF CONTRACT

The work provides for the provision of services commencing on the date of notification of acceptance of tender and ending within a reasonable time specified by the contractor to do the work within 183 calendar days or when the money for the Contract is depleted

A3 TO BE PROVIDED BY TRANSNET

Material will be supplied by Transnet ,at Infra Depot, Beaconsfield to contractor for work to be done. The contractor to supply transport and labour.

A4 TO BE PROVIDED BY CONTRACTOR

In addition to all labour and incidental needed to complete the work, the Contractor shall provide transport , accommodation and food for his employees.

No accommodation on Transnet Property in the section or within station yards.

The Contractor shall provide at his own cost any security measures he may deem necessary for safe and effective execution of the work within the contract area.

All water for the usage during the Contract, shall be provided by the Contractor .

All excess material to be returned to Transnet at Beaconsfield depot, after completion of work.

A suitable vehicle, on contract site for dispersing of material and removing of any injured person, in case of emergency and returning of material to depot. If a second team is necessary, the contractor must arrange accordingly

A5 SCHEDULE OF QUANTITIES AND PRICES

The contractor shall submit with his tender a complete and detailed price schedule (Prepared in ink) for the works No changes will be allowed on Schedule form.

A6 VELD FIRES

Under no circumstances may the Contractor or his employees make open fires within the Transnet reserve that may lead to veld fires. The contractor will be liable for any damages cause by such fires caused by staff on site.

Under no circumstances may the Contractor or his employees collect wood on the Transnet reserve or the adjacent farm land.

A7 REACTION TIME

The Contractor will be available and punctual for callouts throughout the contract period. After being ordered to be on site by the Technical Officer or his/her Deputy, the contractor will start work, as soon as possible, within 24 hours (weekends included).(refer to A4- A6)

PART B : WORKMANSHIP

B1 STANDARDS OF WORKMANSHIP

All work must be done according to the relevant specifications. Where material has been supplied by Transnet and the material has been spoilt or damaged during execution of the work the contractor will be held responsible to make good. All work will be approved by Transnet's representative before payment will be executed.

No payments will be made if work is not according to the specifications of the contract.

Work to be done as per specifications as seen on:-

KY-100-I-67 B erection of 8 wire fence
KY-100-I-67 F Method of securing the fence
KY-100-I-76E Gate posts depth
KY-100-I-67K Method of securing a gate in service road , distance to check
KY-100-I-67L repairing fence with steel sleepers as poles
Culvert both sides and in culvert
Pipe Culvert both sides and in pipe culvert

B2 PERFORMANCE MONITORING AND EVALUATION

The Contractor shall at all times be responsible for supervision of the work and for follow-up inspections and remedial work.

Transnet's representative shall at any time carry out inspections of the Contractors performance, methods and procedures.

B3 REMEDIAL WORK

Remedial work will be performed by the Contractor where the work does not meet the standard of work as specified by the specifications of this contract.

Remedial work will be for the Contractors own costs at no extra charge to Transnet.

B4 PAYMENT

On completion of the work, the Contractor must submit a tax invoice with a copy of the relevant work order attached.

Transnet's representative will certify that the work has been successfully completed and sign the work off.

Payment for work done will be according to the schedule of quantities and prices.

Payment will be made in accordance with clause 25 of the General Conditions of Contract (Minor Works Contracts).

Penalties of R500 per day will be paid for late completion of work.

Payment 30 days after invoice date.

PART C: SAFETY

C1 ASSESSMENT

Prior to the start of the contract the contractor is required to do a risk assessment of each task and to provide a safety plan to address these risks.

C2 SAFETY PLAN

This safety plan is to be provided and implemented by the contractor before the work commences.

C3 RISKS

Provision for the following risks must be made in the safety plan.

1. Working adjacent to passing trains.
2. Loading and off-loading of both new and old material.
3. Travelling to and from work sites on public and mechanization roads.
4. Working close to Overhead Traction equipment. Electrical shock.
5. Uneven surfaces.
6. Transport of staff to and from the work site.
7. Blue asbestos.
8. Veld fires.
9. Transport of injured staff from work site to nearest hospital.

C4 PERSONAL PROTECTION EQUIPMENT

The contractor is to provide personal protection equipment (PPE) in relation to the risk and type of work to be executed.

All workers on this contract shall be required to wear reflective orange vests but not red vests at all times, safety boots. And all necessary PPE as required for the different needs.

(To be supplied by contractor)

C5 TRAINING

Before the contractor may start any work, the contractor supervisor and his entire team will be required to attend a compulsory 3 hour long Safety Induction given by a designated Transnet Safety representative and also the Electric Safety Induction Course, for 3 days. Transnet will supply all the training, but accommodation and transport, to be paid by the Contractor

C6 LIMITS

No work is to be done within a 3 metres distance of a railway line without the presence of a flagman.

C7 SAFETY TALK

The contractor or his supervisor will hold a Safety Talk every morning before work begins to remind the workers to be on the look out for trains and of the dangers of working underneath electrified traction lines. Safety Talk to be recorded in site diary.

C8 TEAM WORK

All workers shall work as a team in one area in the Transnet reserve.

C9 WORK AFTER HOURS

Any work to be done after 18:00 hours the Technical Officer should be notified before hand.

C10. REACTION TIME

Reaction time of the Contractor to site must be as soon as possible ,within 24 hours after receiving an telephone call from Technical Office. Speed limit on service roads is 40 km/h maximum.

C2 SAFETY FILE INFORMATION (to be on site)

1.

Company Registration details/ CK / reg document

Proof of Coida registration

Letter of good standing

Risk assessment

MSDS (material safety data sheet) for each chemical on site

Emergency contact information (list)

Letters of appointment and proof of training for First Aider, fire fighter, and she rep

PPE requirement list to be used for the job being done

List of machinery to be used on site

Working at heights training for persons working above 2m from the ground (scaffolding)

First aid box must be on site with an inspection list

Fire equipment must be on site with an inspection list

Safety talk template and schedule

Proof of induction

Proof of Electification awareness

Training certificates for any person handling machinery

2. Copy of the Contract

"PREVIEW COPY ONLY"



KIMBERLEY NORTH

AS & WHEN FENCING CONTRACT

Project Specifications

CONTENTS

| | | |
|-----------------------------------|---------------------------------------|--------|
| A1 | SCOPE OF WORK | PAGE 1 |
| A2 | DURATION OF CONTRACT | |
| A3 | TO BE PROVIDED BY TRANSNET | |
| A4 | TO BE PROVIDED BY CONTRACTOR | |
| A5 | SCHEDULE OF QUANTITIES AND PRICES | |
| A6 | VELD FIRES | |
| A7 | REACTION TIME | |
| <u>PART B: WORKMANSHIP</u> | | |
| B1 | STANDARDS OF WORKMANSHIP | PAGE 2 |
| B2 | PERFORMANCE MONITORING AND EVALUATION | |
| B3 | REMEDIAL WORK | |
| B4 | PAYMENT | |
| <u>PART C: SAFETY</u> | | |
| C1 | ASSESSMENT | PAGE 3 |
| C2 | SAFETY PLAN | |
| C3 | RISKS | |
| C4 | PERSONAL PROTECTION EQUIPMENT | |
| C5 | TRAINING | |
| C6 | LIMITS | |
| C7 | SAFETY TALK | |
| C8 | TEAM WORK | |
| C9 | WORK AFTER HOURS | |
| C10 | REACTION TIME | |
| C11 | SAFETY FILE ON SITE. | |



KBY/53130 : PRICING SCHEDULE

| ITEM | DESCRIPTION | UNIT OF MEASURE | QUANTITY | TOTAL AMOUNT |
|------|---|-----------------|----------|-----------------|
| 1 | Loading of material at Beaconsfield Depot to site | Kilometre | | |
| 2 | General travelling to site/back (bakkie) | Kilometre | | |
| 3 | Remove old fence | Metres | | |
| 4 | Roll-up old fence into rolls | Metres | | |
| 5 | Clean 1 metre on both sides of fence, remove all bushes etc. | Metres | | |
| 6 | Dig holes for poles 450 mm deep x 400mm diameter | Each | | |
| 7 | Concrete 101mm anchor poles for gate@ 4,2 m(stand 7 days) | Each | | |
| 8 | Concrete 50mm struts for anchor poles(stand 7 days) | Each | | |
| 9 | Concrete 75 mm anchor poles @60 metres crs (stand 7days) | Each | | |
| 10 | Concrete 50mm struts at every 6th pole (stand 7days) | Each | | |
| 11 | Span fence barbed wire | Metres | | |
| 12 | Span Steel Wire | Metres | | |
| 13 | Install Y Standards @ 15 Metres apart & tie to specifications | Each | | |
| 14 | Install Droppers @ 2,5 metres apart & tie to specifications | Each | | |
| 15 | Rail Mast : planting and securing | Each | | |
| 16 | Rail Mast: removing and loading on vehicle | Each | | |
| 17 | Diamond mesh 1,2m high span per metre length | Each | | |
| 18 | Diamond mesh 1,8m high span per metre length | Each | | |
| 19 | Razor mesh 1,2 m span per metre length | Metre | | |
| 20 | Razor Mesh 1.8 m span per metre length | Metre | | |
| 21 | Veldspan 1,2m high | Metres | | |
| 22 | Welding chain,lock and studs | Metres | | |
| 23 | Erecting gate to poles 4,2m x 1,8m gates | Metres | | |
| 24 | Painting of gates | Each | | |
| 25 | Repair of existing fence (where fence is cut or stolen) | Per metre | | |
| 26 | Remove old material to Infra Depot , Beaconsfield | Each | | |
| 27 | Remove access material to Infra Depot , Beaconsfield | Each | | |
| 28 | Paint of poles (complete) | Each | | |
| 29 | Paint of y standards & droppers (200mm from top) | Each | | |
| 30 | To clear area above ,recommended use of TLF | Hour reading | | |
| 31 | Placing of Warning boards on gates or fence | Each | | |
| 32 | Re-alignment of existing gates | Each | | |
| 33 | Safety Requirements | Each | | |
| 34 | P & G 's (include accommodation) | Per hour | | |
| | | | | SUBTOTAL |
| | | | | VAT@14% |
| | | | | TOTAL |

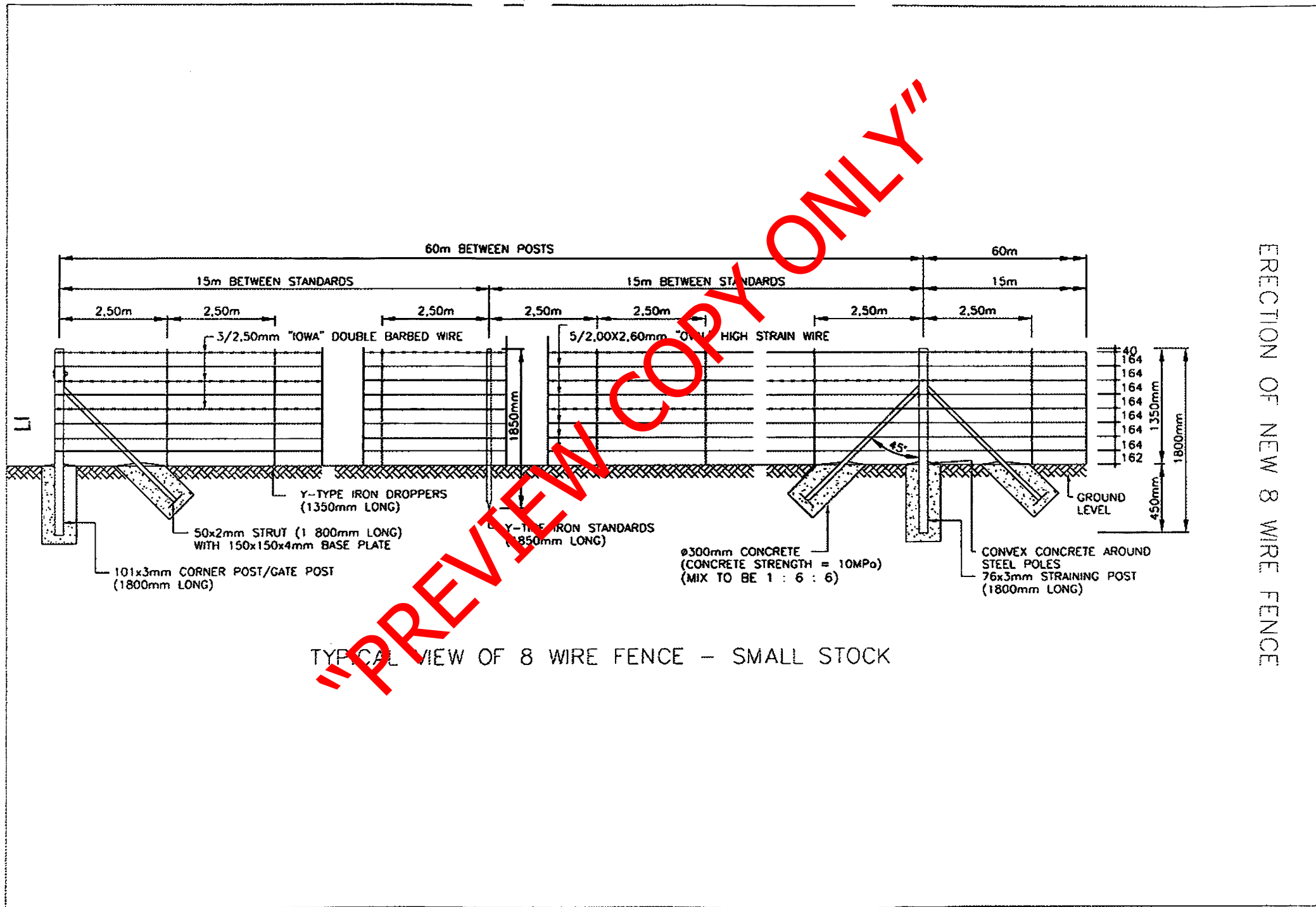

TYPICAL VIEW OF 8 WIRE FENCE - SMALL STOCK

ERECTION OF NEW 8 WIRE FENCE

METHOD OF SECURING WIRE

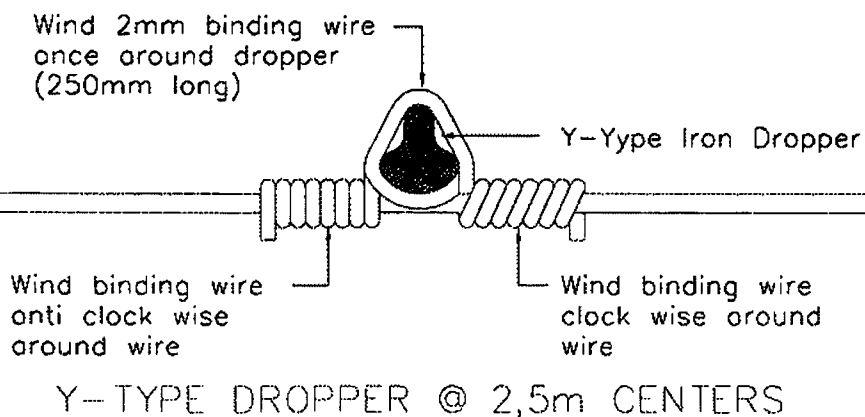
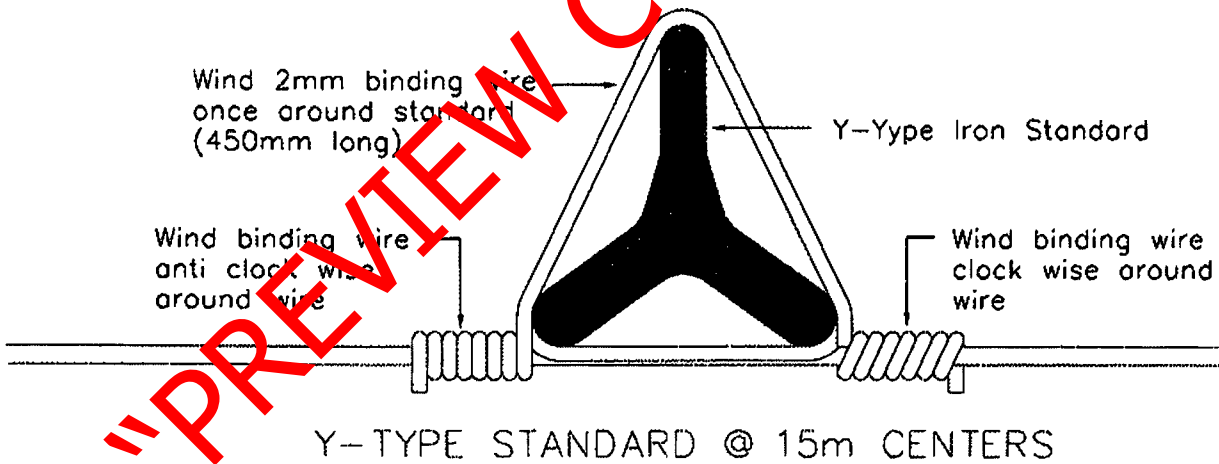
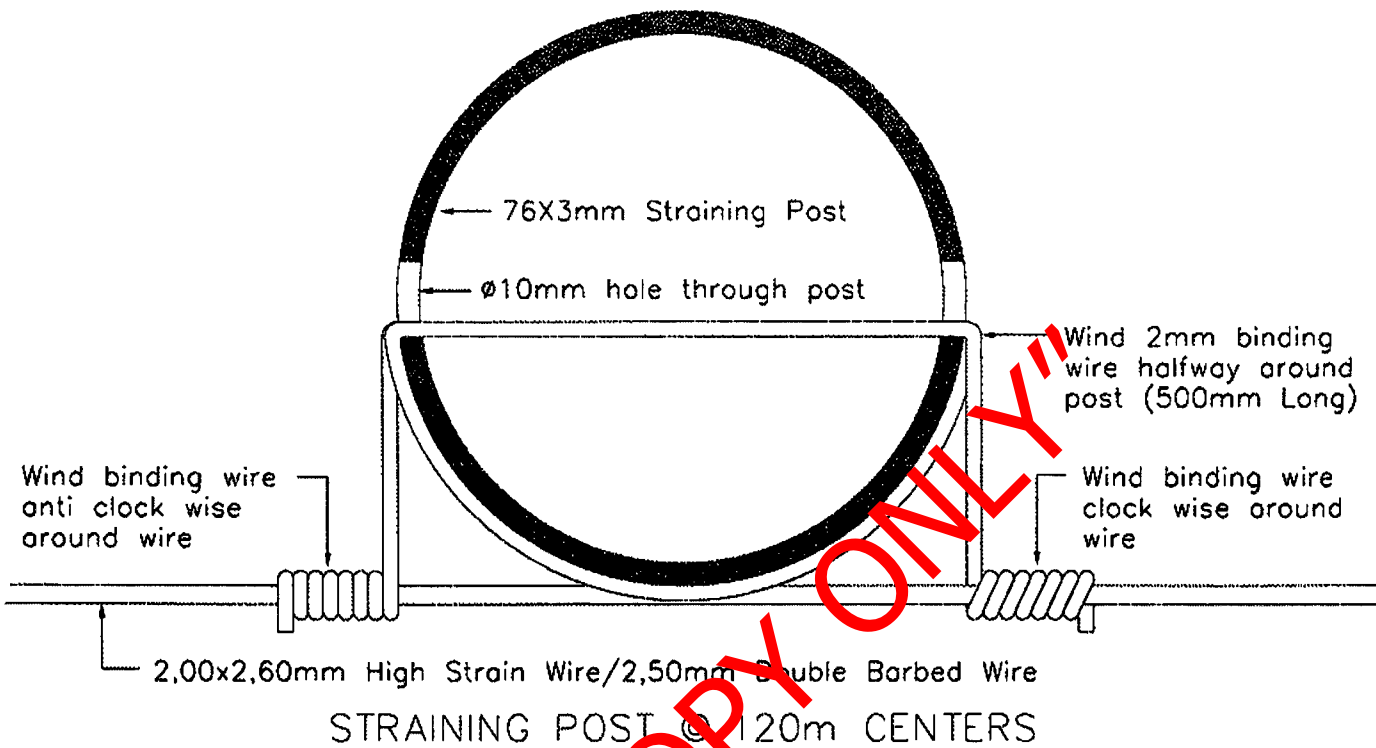

a=erect an addition barbed wire (2 lengths)
b=erecting of veldspan fence

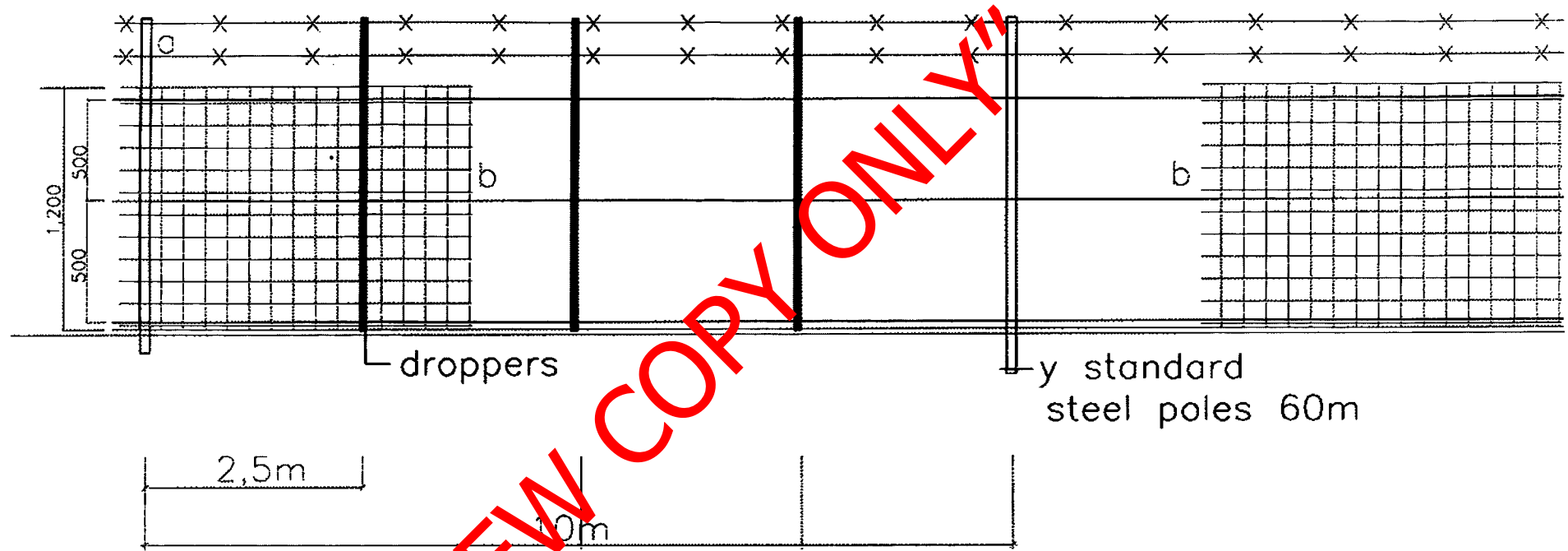

TYPICAL VIEW OF A VELDSPAN FENCE

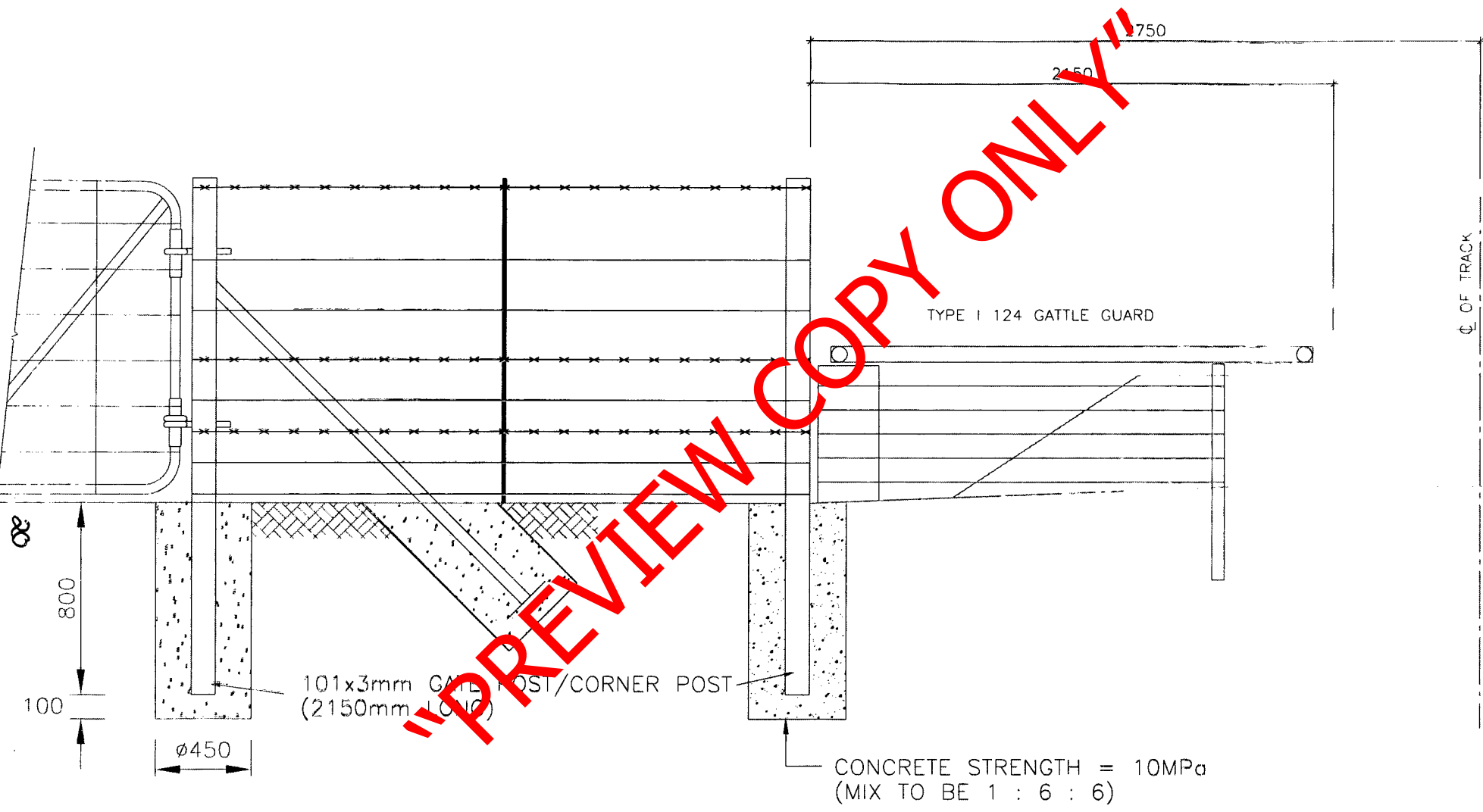

TYPICAL VIEW OF GATTLE POSTS AT CATTLE GUARDS

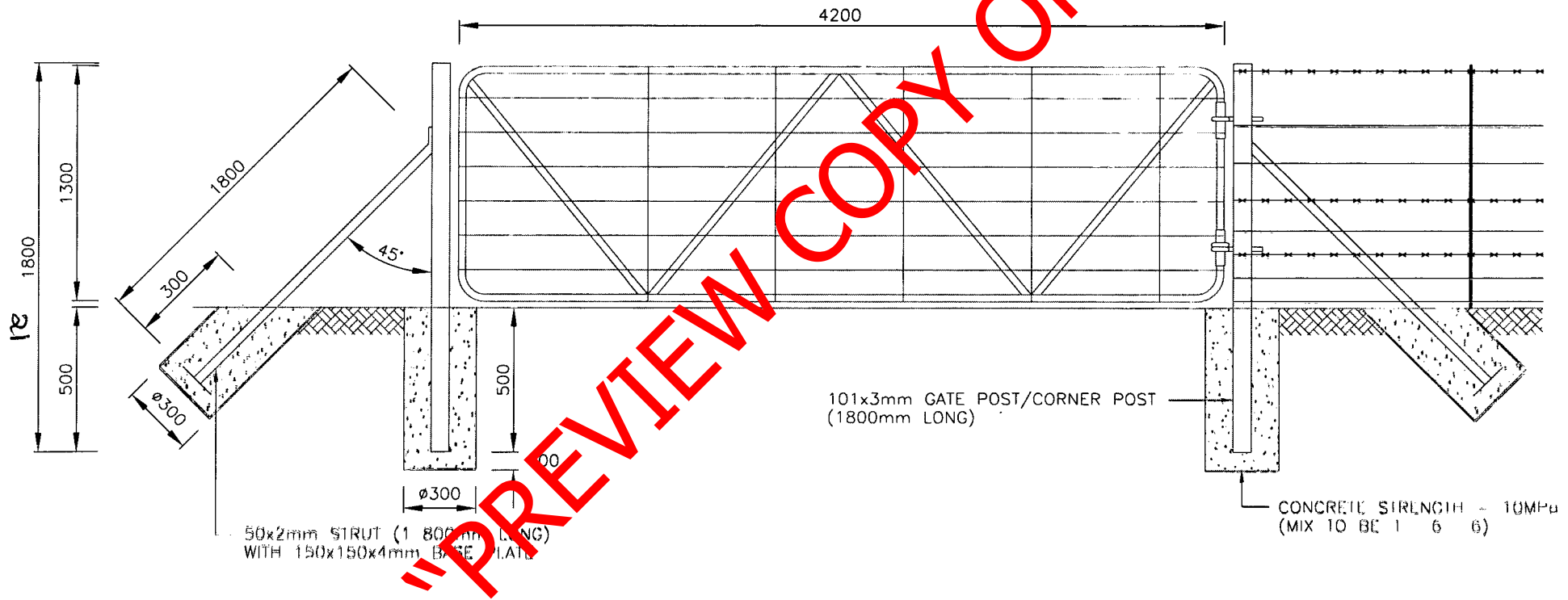

TYPICAL VIEW OF GATE POSTS/CORNER POSTS

TYPICAL VIEW OF GATE POSTS/CORNER POSTS

REV 100 1 67E

"PREVIEW COPY ONLY"

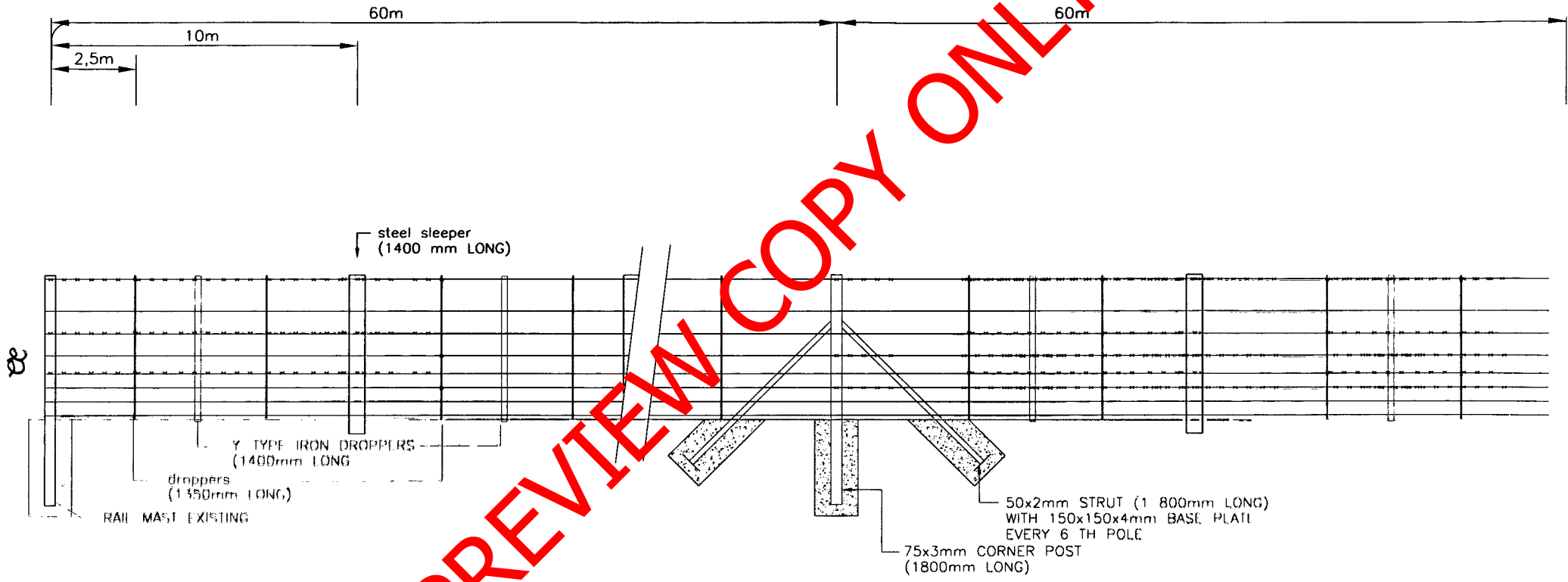

TYPICAL VIEW OF 8 WIRE FENCE
EXISTING STEEL SLEEPERS



ANNEXURE B: B-BBEE IMPROVEMENT PLAN

Transnet encourages its Suppliers/Service Providers to constantly strive to improve their B-BBEE rating. Whereas Respondents will be allocated points in terms of a preference point system based on its B-BBEE scorecard, in addition to such scoring, Transnet also requests that Respondents submit a B-BBEE improvement plan. Respondents are therefore requested to indicate the extent to which their ownership, management control, Supplier Development, Preferential Procurement and Enterprise Development will be maintained or improved over the contract period.

Respondents are requested to submit their B-BBEE Improvement Plan as an additional document with their Proposals.

Respondents are to insert their current status (%) and future targets (%) for the B-BBEE Improvement Plan [i.e. not the % change but the end-state quantum expressed as a percentage] in the table below. This will indicate how you intend to sustain or improve your B-BBEE rating over the contract period. In agreement, this will represent a binding commitment to the successful Respondent.

Transnet reserves the right to request supporting evidence to substantiate the commitments made in the B-BBEE Improvement Plan.

| OWNERSHIP INDICATOR | Required Responses | Current Status (%) | Future Target (%) |
|---|--|--------------------|-------------------|
| 1. The percentage of the business owned by Black ¹ persons. | <i>Provide a commitment based on the extent to which ownership in the hands of Black persons as a percentage of total ownership of the organisation would be sustained or increased over the contract period.</i> | | |
| 2. The percentage of your business owned by Black women. | <i>Provide a commitment based on the extent to which ownership in the hands of Black women as a percentage of total ownership of the organisation would be sustained or increased over the contract period.</i> | | |
| 3. The percentage of the business owned by Black youth | <i>Provide a commitment based on the extent to which ownership in the hands of Black youth as a percentage of total ownership of the organisation would be sustained or increased over the contract period.</i> | | |
| 4. The percentage of the business owned by Black persons living with disabilities | <i>Provide a commitment based on the extent to which ownership in the hands of Black disabled persons as a percentage of total ownership of the organisation would be sustained or increased over the contract period.</i> | | |
| 5. New Entrants ³ (Early stage business) | <i>Provide a commitment based on the extent to which new entrants will be supported over the contract period.</i> | | |

1 **"Black"** means South African Blacks , Coloureds and Indians , as defined in the B-BBEE Act, 53 of 2003

2 **"Black youth"** means Black persons from the age of 16 to 35

3 **"New Entrants"** means an early stage business which is similar to a start-up. However, an early stage business is typically 3 years old or less.

| MANAGEMENT CONTROL INDICATOR | Required Responses | Current Status (%) | Future Targets (%) |
|--|--|---------------------------|---------------------------|
| 6. The percentage of Black Board members in relation to the total number of Board members | <i>Provide a commitment based on the extent to which the number of Black Board members, as a percentage of the total Board, would be sustained or increased over the contract period.</i> | | |
| 7. The percentage of Black female Board members in relation to the total number of Board members | <i>Provide a commitment based on the extent to which the number of Black female Board members, as a percentage of the total Board, would be sustained or increased over the contract period.</i> | | |
| 8. Black Executives directors as a percentage of all executive directors | <i>Provide a commitment based on the extent to which the number of Black executive Directors as a percentage of all Executive Directors would be sustained or increased over the contract period.</i> | | |
| 9. Black female Executives directors as a percentage of all executive directors | <i>Provide a commitment based on the extent to which the number of Black female executive Directors as a percentage of all Executive Directors would be sustained or increased over the contract period.</i> | | |
| Other Executive Management | Required Response | Current Status (%) | Future Targets (%) |
| 10. Black Executive Management as a percentage of all executive directors | <i>Provide a commitment based on the extent to which the number of Black executive Managers as a percentage of all Executive Directors would be sustained or increased over the contract period.</i> | | |
| 11. Black Female Executive Management as a percentage of all executive directors | <i>Provide a commitment based on the extent to which the number of Black female executive Managers as a percentage of all Executive Directors would be sustained or increased over the contract period.</i> | | |
| Senior Management | Required Response | Current Status (%) | Future Targets (%) |
| 12. Black employees in Senior Management as a percentage of all senior management | <i>Provide the percentage of Blacks that would be appointed or retained by the Board and would be operationally involved in the day to day senior management of the business, with individual responsibility for overall and/or financial management of the business and actively involved in the development and implementation of overall strategy, over the contract period.</i> | | |
| 13. Black female employees in Senior Management as a percentage of all senior management | <i>Provide the percentage of Black females that would be appointed or retained by the Board and would be operationally involved in the day to day senior management of the business, with individual responsibility for overall and/or financial management of the business and actively involved in the development and implementation of overall strategy, over the contract period.</i> | | |
| Middle Management | Required Response | Current | Future |

Respondent's Signature

Date & Company Stamp

| | | Status (%) | Targets (%) |
|---|---|---------------------------|---------------------------|
| 14. Black employees in Middle Management as a percentage of all middle management | <i>Provide the percentage of Blacks that would be retained or appointed by the organisation in the middle management cadre and would be operationally involved in the day to day management of the business, with individual responsibility for a particular area within the business and actively involved in the day to day management of the organisation, over the contract period.</i> | | |
| 15. Black female employees in Middle Management as a percentage of all middle management | <i>Provide the percentage of Blacks females that would be retained or appointed by the organisation in the middle management cadre and would be operationally involved in the day to day management of the business, with individual responsibility for a particular area within the business and actively involved in the day to day management of the organisation, over the contract period.</i> | | |
| Junior Management | Required Responses | Current Status (%) | Future Targets (%) |
| 16. Black employees in Junior management as a percentage of all junior management | <i>Provide a commitment based on the extent to which the number of Black Junior Managers as a percentage of the total junior Managers, would be sustained or increased over the contract period.</i> | | |
| 17. Black female employees in Junior management as a percentage of all junior management | <i>Provide a commitment based on the extent to which the number of Black female Junior Managers as a percentage of the total junior Managers, would be sustained or increased over the contract period.</i> | | |
| Employees with disabilities | Required Response | Current Status (%) | Future Targets (%) |
| 18. Black employees with disabilities as a percentage of all employees | <i>Provide a commitment based on the extent to which the percentage of Black disabled employees, in relation to the total of all employees in the organisation, would be sustained or increased over the contract period.</i> | | |
| PREFERENTIAL PROCUREMENT INDICATOR | Required Responses | Current Status (%) | Future Targets (%) |
| 19. B-BBEE procurement spend from all Empowering Suppliers ⁴ based on the B-BBEE procurement | <i>Provide a commitment based on the extent to which B-BBEE spend from all Empowering Suppliers would be sustained or increased over the contract period.</i> | | |

⁴ "Empowering Suppliers" means a B-BBEE compliant entity, which should meet at least three of the following criteria if it is a Large Enterprise or one if it is a QSE:

(a) At least 25% of cost of sales excluding labour cost and depreciation must be procured from local producers or local supplier in SA, for service industry labour cost are included but capped to 15%.

(b) Job creation - 50% of jobs created are for Black people provided that the number of Black employees since the immediate prior verified B-BBEE Measurement is maintained.

(c) At least 25% transformation of raw material/beneficiation which include local manufacturing, production and/or assembly, and/or packaging.

(d) Skills transfer - at least spend 12 days per annum of productivity deployed in assisting Black EMEs and QSEs beneficiaries to increase their operation or financial capacity.

Respondent's Signature

26

Date & Company Stamp

| | | | |
|--|--|--|--|
| recognition level as a percentage of total measured procurement spend | | | |
| 20. 20 B-BBEE procurement spend from all Empowering Suppliers QSEs based on the applicable B-BBEE Procurement Recognition Levels as a percentage of Total Measured Procurement Spend | <i>Provide a commitment based on the extent to which B-BBEE spend from Empowering Supplier QSEs would be sustained or increased over the contract period</i> | | |
| 21. B-BBEE procurement spend from Exempted Micro-Enterprise based on the applicable B-BBEE procurement recognition Levels as a percentage of Total Measured Procurement Spend | <i>Provide a commitment based on the extent to which B-BBEE spend from EMEs would be sustained or increased over the contract period</i> | | |
| 22. B-BBEE procurement spend from Empowering Suppliers that are at least 51% black owned based on the applicable B-BBEE Procurement Recognition Levels as a percentage of Total Measured Procurement Spend | <i>Provide a commitment based on the extent to which spend from Empowering Suppliers who are more than 51% Black-owned would be maintained or increased over the contract period.</i> | | |
| 23. B-BBEE procurement spend from Empowering Suppliers that are at least 30% black women owned based on the applicable B-BBEE Procurement Recognition Levels as a percentage of Total Measured Procurement Spend | <i>Provide a commitment based on the extent to which spend from Empowering Suppliers who are more than 30% Black women-owned would be maintained or increased over the contract period.</i> | | |
| 24. B-BBEE procurement Spent from Designated Group ⁵ Suppliers that are at least 51% Black owned | <i>Provide a commitment based on the extent to which spend from suppliers from Designated Group Suppliers that are at least 51% Black owned would be maintained or increased over the contract period.</i> | | |

⁵ "Designated Groups" means:

- a) unemployed black people not attending and required by law to attend an educational institution and not awaiting admission to an educational institution;
- b) black people who are youth as defined in the National Youth Commission Act of 1996;
- c) black people who are persons with disabilities as defined in the Codes of Good Practice on employment of people with disabilities issued under the Employment Equity Act;
- d) black people living in rural and under developed areas; and
- e) black military veterans who qualifies to be called a military veteran in terms of the Military Veterans Act 18 of 2011.

Respondent's Signature

21

Date & Company Stamp

| SUPPLIER DEVELOPMENT INDICATOR | Required Response | Current Status (%) | Future Target (%) |
|---|--|---------------------------|--------------------------|
| 25. Annual value of all Supplier Development ⁶ Contributions made by the Measured entity as a percentage of the target | <i>Provide a commitment based on the percentage in your organisation's annual spend on Supplier Development initiatives, will be maintained or improved over the contract period.</i> | | |
| ENTERPRISE DEVELOPMENT INDICATOR | Required Response | Current Status (%) | Future Target (%) |
| 26. The organisation's annual spend on Enterprise Development ⁷ as a percentage of Net Profit after Tax [NPAT] | <i>Provide a commitment based on the retention or increase in your organisation's annual spend on Enterprise Development initiatives, as a percentage of its Net Profit after Tax, over the contract period.</i> | | |

"PREVIEW COPY ONLY"

⁶ **"Supplier Development"** means monetary or non-monetary contributions carried out for the benefit of value-adding suppliers to the Measured Entity, with the objective of contributing to the development, sustainability and financial and operational independence of those beneficiaries:

(a) Supplier Development Contributions to suppliers that are Exempted Micro-Enterprises or Qualifying Small Enterprises which are at least 51% black owned or at least 51% black women owned.

Supplier Development within the contest of the B-BBEE scorecard must be differentiated from Transnet's Supplier Development Initiatives. Whereas the former relates to the definition above, the latter relates to improving the socio-economic environment through initiatives that are committed to as part of a contract award that contribute to the development of a competitive supplier base in relation to a particular industry.

⁷ **"Enterprise Development"** means monetary and non-monetary contributions carried out for the following beneficiaries, with the objective of contributing to the development, sustainability and financial and operational independence of those beneficiaries:

(a) Enterprise Development Contributions to Exempted Micro-Enterprises or Qualifying Small Enterprises which are at least 51% Black owned or at least 51% Black women owned;

Respondent's Signature

28

Date & Company Stamp

RFQ NO. KBY/53130
FOR THE AS WHEN REQUIRED, REPAIRS AND ERECTION OF FENCE AT THE
KIMBERLEY NORTH SUBSTATIONS FOR A PERIOD OF SIX (6) MONTHS.

ANNEXURE A: B-BBEE PREFERENCE POINTS CLAIM FORM

This preference form contains general information and serves as a claim for preference points for Broad-Based Black Economic Empowerment [**B-BBEE**] Status Level of Contribution.

1. INTRODUCTION

- 1.1 A total/maximum of 20 preference points shall be awarded for B-BBEE Status Level of Contribution.
- 1.2 Failure on the part of a Bidder to fill in and/or to sign this form and submit a B-BBEE Verification Certificate from a Verification Agency accredited by the South African Accreditation System [**SANAS**] or a Registered Auditor approved by the Independent Regulatory Board of Auditors [**IRBA**] or an Accounting Officer as contemplated in the Close Corporation Act [**CCA**] together with the bid will be interpreted to mean that preference points for B-BBEE Status Level of Contribution are not claimed.
- 1.3 Transnet reserves the right to require of a Bidder, either before a Bid is adjudicated or at any time subsequently, to substantiate any claim in regard to preferences, in any manner required by Transnet.

2. GENERAL DEFINITIONS

- 2.1 "**all applicable taxes**" include value-added tax, pay as you earn, income tax, unemployment insurance fund contributions and skills development levies;
- 2.2 "**B-BBEE**" means broad-based black economic empowerment as defined in section 1 of the Broad-Based Black Economic Empowerment Act;
- 2.3 "**B-BBEE status of contributor**" means the B-BBEE status received by a measured entity based on its overall performance using the relevant scorecard contained in the Codes of Good Practice on Black Economic Empowerment, issued in terms of section 9(1) of the Broad-Based Black Economic Empowerment Act;
- 2.4 "**Bid**" means a written offer in a prescribed or stipulated form in response to an invitation by Transnet for the provision of goods, works or services;
- 2.5 "**Broad-Based Black Economic Empowerment Act**" means the Broad-Based Black Economic Empowerment Act, 2003 [Act No. 53 of 2003];
- 2.6 "**comparative price**" means the price after the factors of a non-firm price and all unconditional discounts that can be utilised have been taken into consideration;
- 2.7 "**consortium or joint venture**" means an association of persons for the purpose of combining their expertise, property, capital, efforts, skills and knowledge in an activity for the execution of a contract;

- 2.8 **"contract"** means the agreement that results from the acceptance of a bid by Transnet;
- 2.9 **"EME"** means any enterprise with an annual total revenue of R5 [five] million or less as per the 2007 version of the B-BBEE Codes of Good Practice and means any enterprise with an annual total revenue of R10 [ten] million or less as per the Revised Codes of Good Practice issued on 11 October 2013 in terms of Government Gazette No. 36928;
- 2.10 **"firm price"** means the price that is only subject to adjustments in accordance with the actual increase or decrease resulting from the change, imposition, or abolition of customs and excise duty and any other duty, levy, or tax, which, in terms of the law or regulation, is binding on the contractor and demonstrably has an influence on the price of any supplies, or the rendering costs of any service, for the execution of the contract;
- 2.11 **"functionality"** means the measurement according to predetermined norms, as set out in the bid documents, of a service or commodity that is designed to be practical and useful, working or operating, taking into account, among other factors, the quality, reliability, viability and durability of a service and the technical capacity and ability of a bidder;
- 2.12 **"non-firm prices"** means all prices other than "firm" prices;
- 2.13 **"person"** includes reference to a juristic person;
- 2.14 **"QSE"** means any enterprise with an annual total revenue between R5 [five] million and R35 [thirty five] million as per the 2007 version of the B-BBEE Codes of Good Practice and means any enterprise with an annual total revenue of between R10 [ten] million and R50 [fifty] million as per the Revised Codes of Good Practice issued on 11 October 2013 in terms of Government Gazette No. 36928
- 2.15 **"rand value"** means the total estimated value of a contract in South African currency, calculated at the time of bid invitations, and includes all applicable taxes and excise duties;
- 2.16 **"subcontract"** means the primary contractor's assigning or leasing or making out work to, or employing another person to support such primary contractor in the execution of part of a project in terms of the contract;
- 2.17 **"total revenue"** bears the same meaning assigned to this expression in the Codes of Good Practice on Black Economic Empowerment, issued in terms of section 9(1) of the Broad-Based Black Empowerment Act and promulgated in the Government Gazette on 9 February 2007;
- 2.18 **"trust"** means the arrangement through which the property of one person is made over or bequeathed to a trustee to administer such property for the benefit of another person; and
- 2.19 **"trustee"** means any person, including the founder of a trust, to whom property is bequeathed in order for such property to be administered for the benefit of another person.

3. ADJUDICATION USING A POINT SYSTEM

- 3.1 The Bidder obtaining the highest number of total points for the evaluation criteria as enumerated in Section 2 of the RFP will be awarded the contract, unless objective criteria justifies the award to another bidder.
- 3.2 Preference points shall be calculated after prices have been brought to a comparative basis taking into account all factors of non-firm prices and all unconditional discounts.

- 3.3 Points scored will be rounded off to 2 [two] decimal places.
- 3.4 In the event of equal points scored, the Bid will be awarded to the Bidder scoring the highest number of preference points for B-BBEE.
- 3.5 However, when functionality is part of the evaluation process and two or more Bids have scored equal points including equal preference points for B-BBEE, the successful Bid will be the one scoring the highest score for functionality.
- 3.6 Should two or more Bids be equal in all respect, the award shall be decided by the drawing of lots.

"PREVIEW COPY ONLY"

4. POINTS AWARDED FOR B-BBEE STATUS LEVEL OF CONTRIBUTION

- 4.1 In terms of the Preferential Procurement Regulations, 2011, preference points shall be awarded to a Bidder for attaining the B-BBEE status level of contribution in accordance with the table below:

| B-BBEE Status Level of Contributor | Number of Points [Maximum 20] |
|------------------------------------|----------------------------------|
| 1 | 20 |
| 2 | 18 |
| 3 | 16 |
| 4 | 12 |
| 5 | 8 |
| 6 | 6 |
| 7 | 4 |
| 8 | 2 |
| Non-compliant contributor | 0 |

- 4.2 Bidders who qualify as EMEs in terms of the 2007 version of the Codes of Good Practice must submit a certificate issued by an Accounting Officer as contemplated in the CCA or a Verification Agency accredited by SANAS or a Registered Auditor. Registered auditors do not need to meet the prerequisite for IRBA's approval for the purpose of conducting verification and issuing EME's with B-BBEE Status Level Certificates.
- 4.3 Bidders who qualify as EMEs in terms of the Revised Codes of Good Practice issued on 11 October 2013 in terms of Government Gazette No. 36928 are only required to obtain a sworn affidavit on an annual basis confirming that the entity has an Annual Total Revenue of R10 million or less and the entity's Level of Black ownership.
- 4.4 In terms of the 2007 version of the Codes of Good Practice, Bidders other than EMEs must submit their original and valid B-BBEE status level verification certificate or a certified copy thereof, substantiating their B-BBEE rating issued by a Registered Auditor approved by IRBA or a Verification Agency accredited by SANAS.
- 4.5 In terms of the Revised Codes of Good Practice issued on 11 October 2013 in terms of Government Gazette No. 36928, Bidders who qualify as QSEs are only required to obtain a sworn affidavit on an annual basis confirming that the entity has an Annual Total Revenue of R50 million or less and the entity's Level of Black ownership. Large enterprises must submit their original and valid B-BBEE status level verification certificate or a certified copy thereof, substantiating their B-BBEE rating issued by a Registered Auditor approved by IRBA or a Verification Agency accredited by SANAS.
- 4.6 A trust, consortium or joint venture will qualify for points for its B-BBEE status level as a legal entity, provided that the entity submits its B-BBEE status level certificate.
- 4.7 A trust, consortium or joint venture will qualify for points for their B-BBEE status level as an unincorporated entity, provided that the entity submits their consolidated B-BBEE scorecard as if they were a group structure and that such a consolidated B-BBEE scorecard is prepared for every separate bid.

- 4.8 Tertiary institutions and public entities will be required to submit their B-BBEE status level certificates in terms of the specialised scorecard contained in the B-BBEE Codes of Good Practice.
- 4.9 A person will not be awarded points for B-BBEE status level if it is indicated in the Bid documents that such a Bidder intends subcontracting more than 25% [twenty-five per cent] of the value of the contract to any other enterprise that does not qualify for at least the same number of points that such a Bidder qualifies for, unless the intended subcontractor is an EME that has the capability and ability to execute the subcontract.
- 4.10 A person awarded a contract may not subcontract more than 25% [twenty-five per cent] of the value of the contract to any other enterprise that does not have an equal or higher B-BBEE status level than the person concerned, unless the contract is subcontracted to an EME that has the capability and ability to execute the subcontract.
- 4.11 Bidders are to note that in terms of paragraph 2.6 of Statement 000 of the Revised Codes of Good Practice issued on 11 October 2013 in terms of Government Gazette No. 36928, any representation made by an entity about its B-BBEE compliance must be supported by suitable evidence or documentation. As such, Transnet reserves the right to request such evidence or documentation from Bidders in order to verify any B-BBEE recognition claimed.

5. B-BBEE STATUS AND SUBCONTRACTING

5.1 Bidders who claim points in respect of B-BBEE Status Level of Contribution must complete the following:

B-BBEE Status Level of Contribution _____/1 = _____ [maximum of 20 points]

Note: Points claimed in respect of this paragraph 5.1 must be in accordance with the table reflected in paragraph 4.1 above and must be substantiated by means of a B-BBEE certificate issued by a Verification Agency accredited by SANAS or a Registered Auditor approved by IRBA or a sworn affidavit in the case of an EME or QSE.

5.2 Subcontracting:

Will any portion of the contract be subcontracted? YES/NO [delete which is not applicable]

If YES, indicate:

- (i) What percentage of the contract will be subcontracted?%
- (ii) The name of the subcontractor
- (iii) The B-BBEE status level of the subcontractor
- (iv) Is the subcontractor an EME? YES/NO

5.3 Declaration with regard to Company/Firm

- (i) Name of Company/Firm.....
- (ii) VAT registration number.....
- (iii) Company registration number.....
- (iv) Type of Company / Firm [TICK APPLICABLE BOX]

- Partnership/Joint Venture/Consortium
- One person business/sole propriety
- Close Corporations

Company (Pty) Ltd

(v) Describe Principal Business Activities

.....
.....
.....

(vi) Company Classification [TICK APPLICABLE BOX]

Manufacturer

Supplier

Professional Service Provider

Other Service Providers, e.g. Transporter, etc.

(vii) Total number of years the company/firm has been in business

BID DECLARATION

I/we, the undersigned, who warrants that he/she is duly authorised to do so on behalf of the company/firm, certify that points claimed, based on the B-BBEE status level of contribution indicated in paragraph 4 above, qualifies the company/firm for the preference(s) shown and I / we acknowledge that:

- (i) The information furnished is true and correct.
- (ii) In the event of a contract being awarded as a result of points claimed as shown in paragraph 6 above, the contractor may be required to furnish documentary proof to the satisfaction of Transnet that the claims are correct.
- (iii) If the B-BBEE status level of contribution has been claimed or obtained on a fraudulent basis or any of the conditions of contract have not been fulfilled, Transnet may, in addition to any other remedy it may have:
 - (a) disqualify the person from the bidding process;
 - (b) recover costs, losses or damages it has incurred or suffered as a result of that person's conduct;
 - (c) cancel the contract and claim any damages which it has suffered as a result of having to make less favourable arrangements due to such cancellation;
 - (d) restrict the Bidder or contractor, its shareholders and directors, and/or associated entities, or only the shareholders and directors who acted in a fraudulent manner, from obtaining business from Transnet for a period not exceeding 10 years, after the *audi alteram partem* [hear the other side] rule has been applied; and/or
 - (e) forward the matter for criminal prosecution.

"PREVIEW COPY ONLY"

WITNESSES:

- 1.
- 2.

SIGNATURE OF BIDDER

DATE:.....

COMPANY NAME:

ADDRESS:.....