



# INFRASTRUCTURE MAINTENANCE

## SPECIFICATION

### Specification For A Hydraulic Driven, Double Bladed Weld Shearing Machine

**PREVIEW COPY ONLY**

Author: Chief Engineering Technician  
Small Plant & Equipment  
Approved: Senior Engineer  
Technology Management  
Authorised: Senior Engineer  
Technology Management

Ashwin Singh

Handwritten signature of Ashwin Singh in black ink, positioned above a dotted line.

Colin Blandford

Handwritten signature of Colin Blandford in black ink, positioned above a dotted line.

Colin Blandford

Handwritten signature of Colin Blandford in black ink, positioned above a dotted line.

Date: 08 September 2008

Circulation Restricted To:

Transnet Freight Rail - Infrastructure

© This document as a whole is protected by copyright. The information herein is the sole property of Transnet Ltd. It may not be used, disclosed or reproduced in part or in whole in any manner whatsoever, except with the written permission of and in a manner permitted by the proprietors.

# Contents

1. General Requirements.....	3
2. Operating Conditions.....	3
3. Qualifications.....	3
4. Performance.....	3
5. General Requirements.....	4
6. Detailed Requirements.....	4
6.1 Preferred Mass.....	4
6.2 Hydraulic System Requirements.....	4
6.3 Mobility.....	4
6.4 Noise Emission.....	4
6.5 Shear Blades.....	5
6.6 Shearing Force.....	5
6.7 Stroke.....	5
6.8 Positioning of Controls.....	5
6.9 Component Markings.....	5
6.10 Body.....	5
6.11 Ergonomics.....	5
7. Quality Control.....	6
8. Legal and Operational.....	6
9. Annexure A.....	7

“PREVIEW COPY ONLY”

## 1. General Requirements

- 1.1 This specification outlines the requirements of a heavy-duty, hydraulically operated rail profile grinding machine.

## 2. Operating Conditions

- 2.1 Machines will be operated in all weather conditions at altitudes varying from sea level to 1850 m above sea level, relative humidity 10% to 90% and atmospheric conditions which vary from heavily saline to dry and dusty.

- 2.2 Ambient air temperatures ranging from -5° C to 45° C.

## 3. Qualifications

- 3.1 The design of the machine is to be that of the manufacturer, but must be of robust construction in order to meet the sustained heavy-duty demands of railway infrastructure maintenance.
- 3.2 A “no-tool” adjustment machine is preferred.
- 3.3 Machines will be acceptable in standard factory production finish and colour. Details to be furnished.
- 3.4 Only products proven in service will be considered. A list of users, both South African and international, is to be submitted.

## 4. Performance

- 4.1 A service life of not less than 7 years is expected from each machine. The actual design life of the machines is to be stated.
- 4.2 The machines are to be easily and economically maintained with standard workshop tools and equipment.
- 4.3 The machine must be compatible with hydraulic oil of viscosity grades 46 and 68 – details as per SANS 1218:2005 (Hydraulic Oil – Anti-wear Type).

## 5. General Requirements

- 5.1 This specification outlines the requirements of a heavy-duty hydraulically operated, double bladed weld shearing machine.
- 5.2 The machine will be used to shear excess metal from rails after exothermic welding.

## 6. Detailed Requirements

### 6.1 Preferred Mass

- 6.1.1 The mass of the grinder, including shearing blades, must not exceed 40 kg.

### 6.2 Hydraulic System Requirements

- 6.2.1 The machine must comply to HTMA standards for hydraulic tool operation.
- 6.2.2 The machine must operate on the "Open Centre Circuit" hydraulic system.
- 6.2.3 The hydraulic supply will meet the requirements of HTMA Type RR System and the rail drill must operate effectively on this standard.
- 6.2.4 The grinder must be equipped with 12mm ( $\frac{1}{2}$ " ) hydraulic whip hoses that comply to DIN EN 853 - 2SN (Rubber Hoses and Hose Assemblies - Wire Braid Reinforced Hydraulic Type).
- 6.2.5 The whip hoses must be 400mm long.
- 6.2.6 The whip hoses must be fitted with 12mm ( $\frac{1}{2}$ " ) fixed male and female quick release flat-face fittings that comply to HTMA standards. The quick release fittings must be fitted with dust caps.
- 6.2.7 Hose connections must be placed in a position that would assist in the balance of the machine and make it easy for the operator to handle and move the machine.
- 6.2.8 Coupling points are to indicate whether they are supply or return points.

### 6.3 Mobility

- 6.3.1 Heavy duty clamps must be provided to clamp the machine under the rail head while at the same time, allowing horizontal movement of the machine when shearing takes place.

### 6.4 Noise Emission

- 6.4.1 The grinder must comply to BS EN ISO 4871:1997 (Declaration and verification of noise emission values of machinery and equipment).

## 6.5 Shear Blades

- 6.5.1 Each machine must be supplied with a set of shearing blades suitable for 48 kg/m and 57 kg/m rails – profiles as per Annexure A. However the use of these machines will not be limited to the above two rail profiles
- 6.5.2 The shear blades to consist of a casting that matches the profile of the rail and must be so designed that cutting below the running surface and flanks is not possible.
- 6.5.3 The cutting edges of the shear blades to be of heat resistant steel and must be able to be re-sharpened.
- 6.5.4 Sufficient weld material must be left on the rail surface and flanks after trimming to enable proper grinding of the rail profile.

## 6.6 Shearing Force

- 6.6.1 The machine must have a shearing force sufficient to effectively shear excess exothermic weld on the various rail profiles as per Annexure A.

## 6.7 Stroke

- 6.7.1 The minimum stroke of the cutting blades must be 140mm.

## 6.8 Positioning of Controls

- 6.8.1 The controls must be easily accessible to the operator and must give a clear indication whether the shearing blades are in the advance or retract phase.

## 6.9 Component Markings

- 6.9.1 The machine is to be clearly marked in respect of hydraulic oil flow required.
- 6.9.1 Coupling points are also to indicate whether they are supply or return points.

## 6.10 Body

- 6.10.1 The frame and components of the machine must be robust.
- 6.10.2 The machine must be well protected against rust.
- 6.10.3 The grip on the handles must have a non-slip surface.
- 6.10.4 The machines will be accepted in standard factory finish and colour.  
Due cognisance must be given to the life requirement of the machine.

## 6.11 Ergonomics

- 6.11. The tool must be ergonomically designed for maximum operator productivity, safety and transportability.

## 7. Quality Control

- 7.1 All machines must be manufactured in an environment that complies to the latest ISO 9000 to ISO 9004 or similar quality control standards. Details must be furnished.
- 7.2 Machines will be subject to a technical evaluation and the final decision will, amongst others, be based on these findings.

## 8. Legal and Operational

- 8.1 All machines must comply with the requirements of the Machinery and Occupational Safety Act, (Act 85 of 1993 – General Machinery Regulations) and The Machinery Directive 98/37/EC.
- 8.2 The rail drill must be completely assembled and filled with lubricants and ready for service in all respects.
- 8.3 Where grease nipples are fitted these are to be to DIN 71412 in easily accessible positions. Full details of lubrication applicable to machines on offer to be submitted.
- 8.4 An operator's handbook, service manual and spare parts list must be supplied with each machine in order to ensure that the machine is operated in accordance to the manufacturer's instructions.
- 8.5 All machines and equipment must be supplied complete with essential tools such as allen keys, spanners etc. in order to make essential adjustments as well as to fit or remove consumable items.
- 8.6 Suppliers of hydraulic machinery will be required to stock a full range of readily available spare parts required for the maintenance of these machines throughout their life span. Full details of service organisation is to be submitted.
- 8.7 Consumable items must be available locally and must be of standardised format in order to be used on equipment of more than one supplier.
- 8.8 All machines and equipment is to be guaranteed for a minimum period of 12 months against faulty material and workmanship - fair wear and tear excluded. Full details of guarantee is to be submitted.
- 8.9 The information as requested by the various clauses in this specification are to be supplied in the form of technical data, pamphlets and/or drawings. If this is not complied to, offers may be overlooked.
- 8.10 Each machine purchased will be issued with a project number consisting of 20 characters which must be stamped or engraved directly onto the machine or on the manufacturer's data plate or a separate riveted plate on the particular machine.
- 8.11 Sufficient training must be given to all operators of these machines.
- 8.12 Machines not already in service with Transnet Freight Rail must be made available for testing/evaluation during the adjudication of the tender. Technical improvements on existing machines/equipment is to be substantiated by physical examples.

## Annexure A

“PREVIEW COPY ONLY”

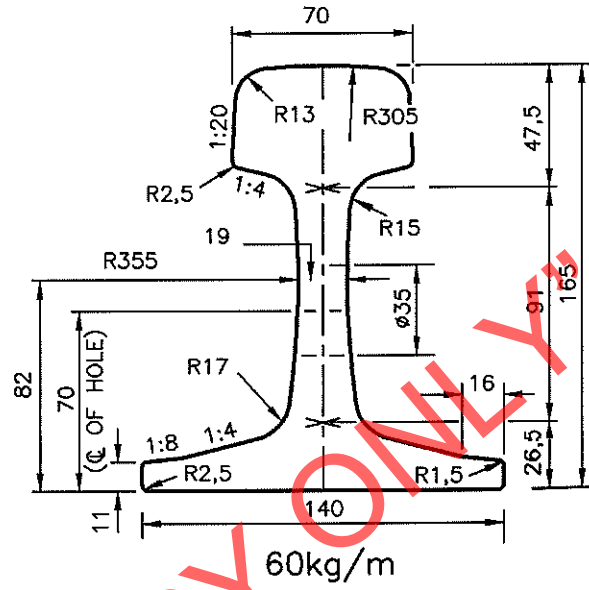
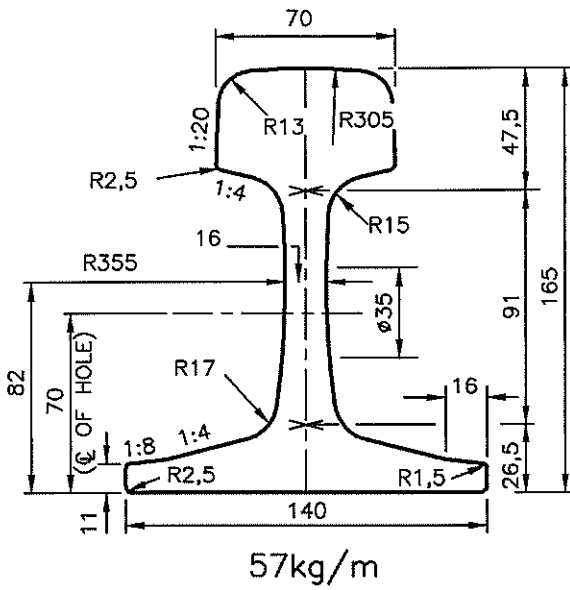

(FLEXIBLE POINTS BLADE  
AND UNDERCUT STOCK RAIL)

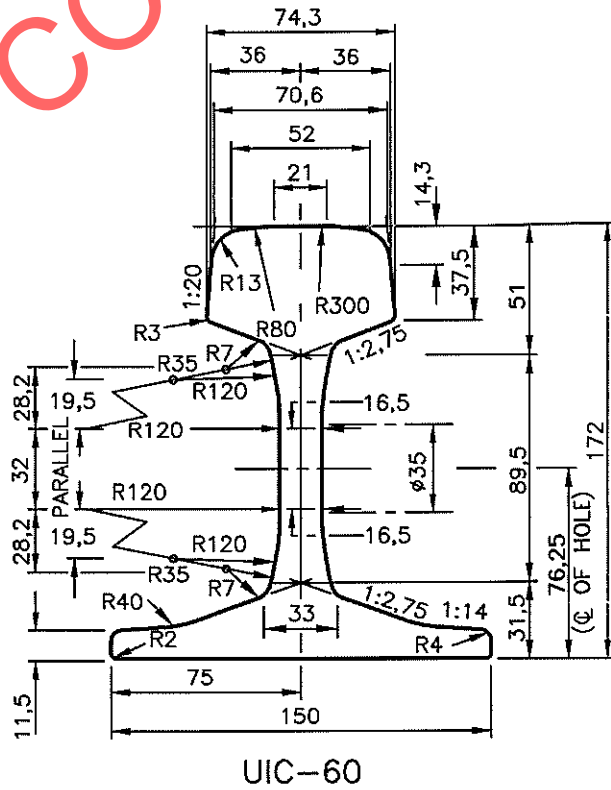
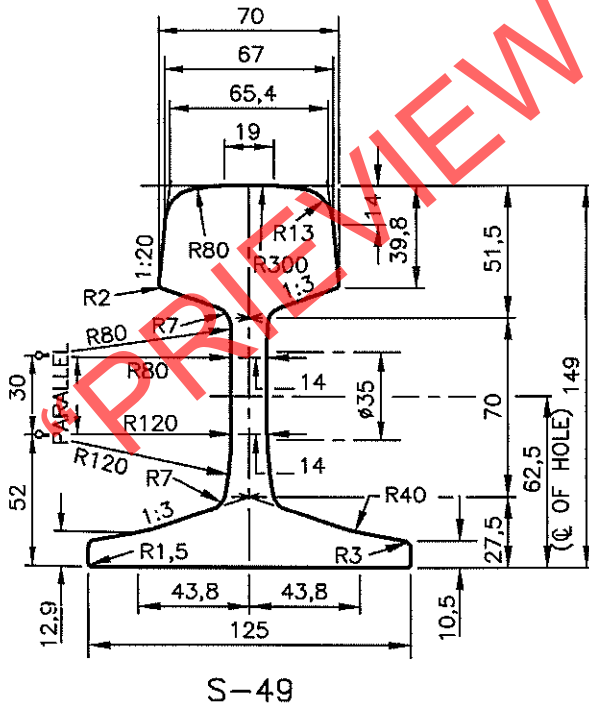

REMARKS:

- FOR PROPERTIES SEE ANNEXURE 14 SHT 4.

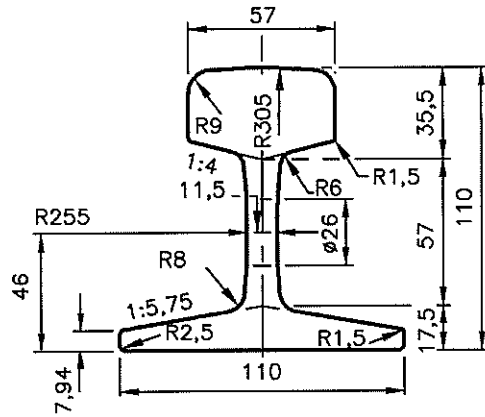

30kg/m

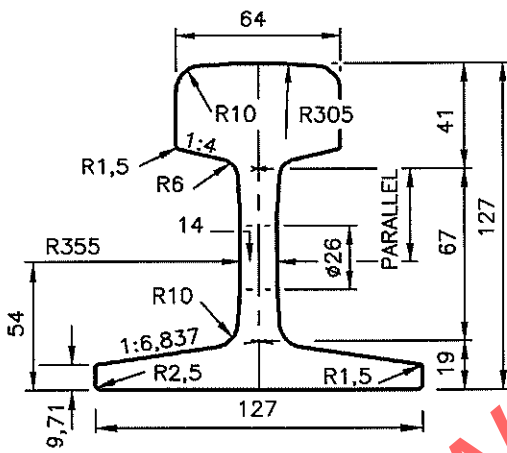

40kg/m

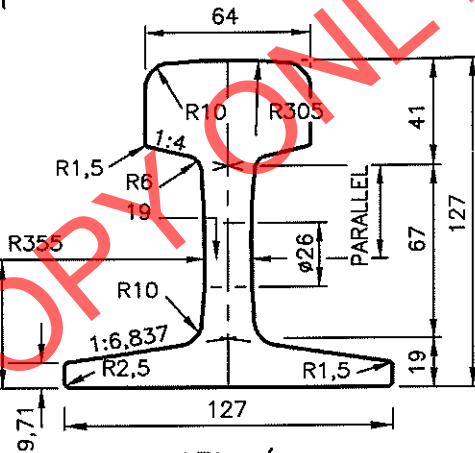

43kg/m  
(HARBOUR AREAS)

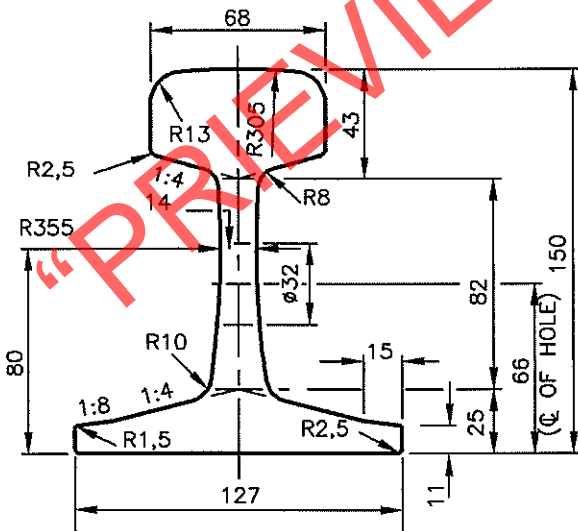

48kg/m

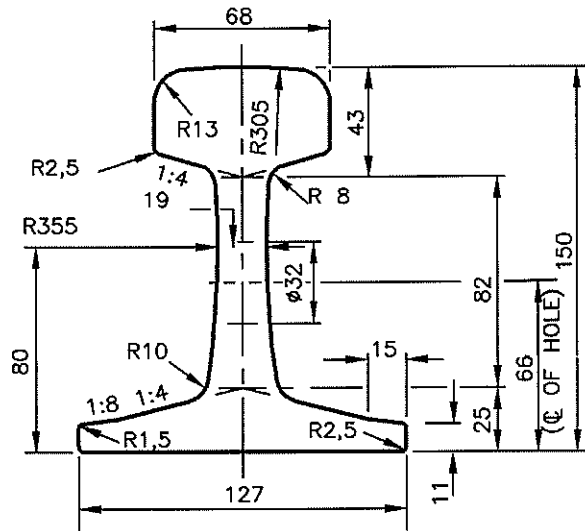

51kg/m  
(FLEXIBLE POINTS BLADE  
AND UNDERCUT STOCK RAIL)

REMARKS:

1. FOR PROPERTIES SEE ANNEXURE 14 SHT 4.

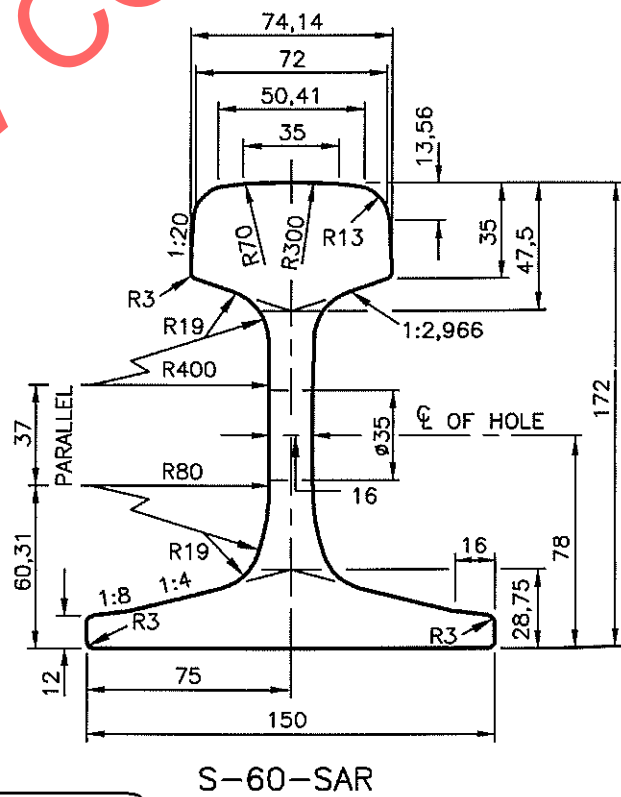
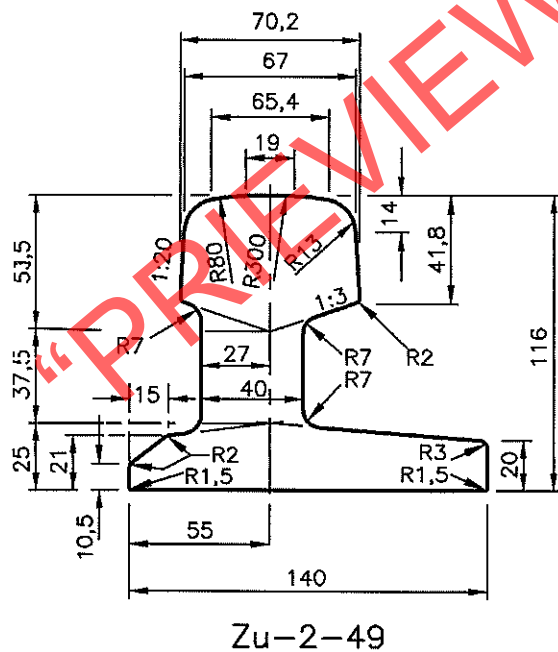
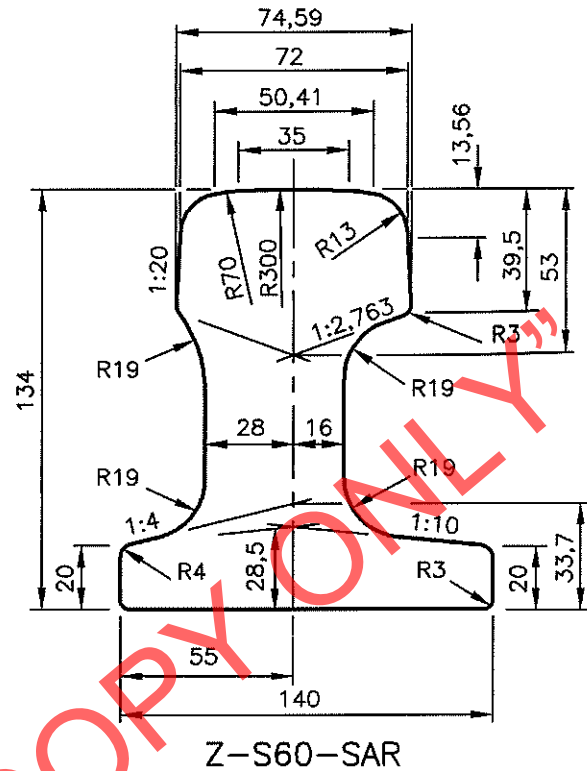
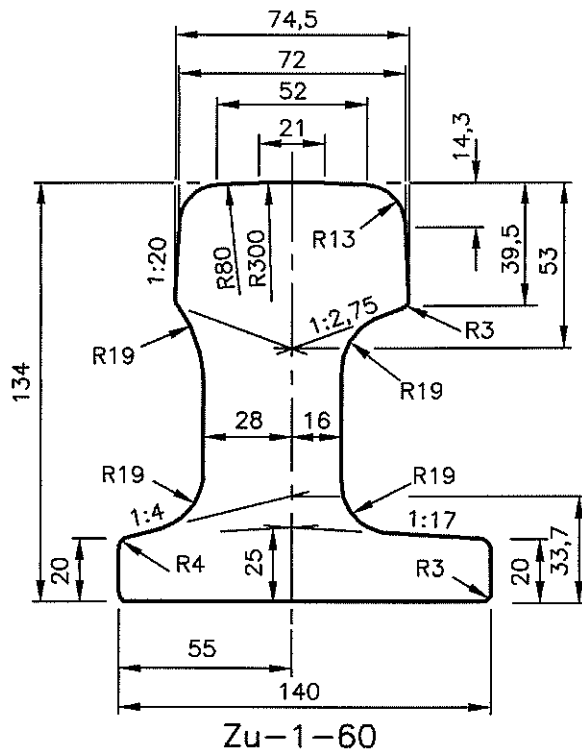

REMARKS:

- FOR PROPERTIES SEE ANNEXURE 14 SHT 4.



# 60E1

VIGNOLSCHIENE, FLAT BOTTOM RAIL, RAIL VIGNOLE

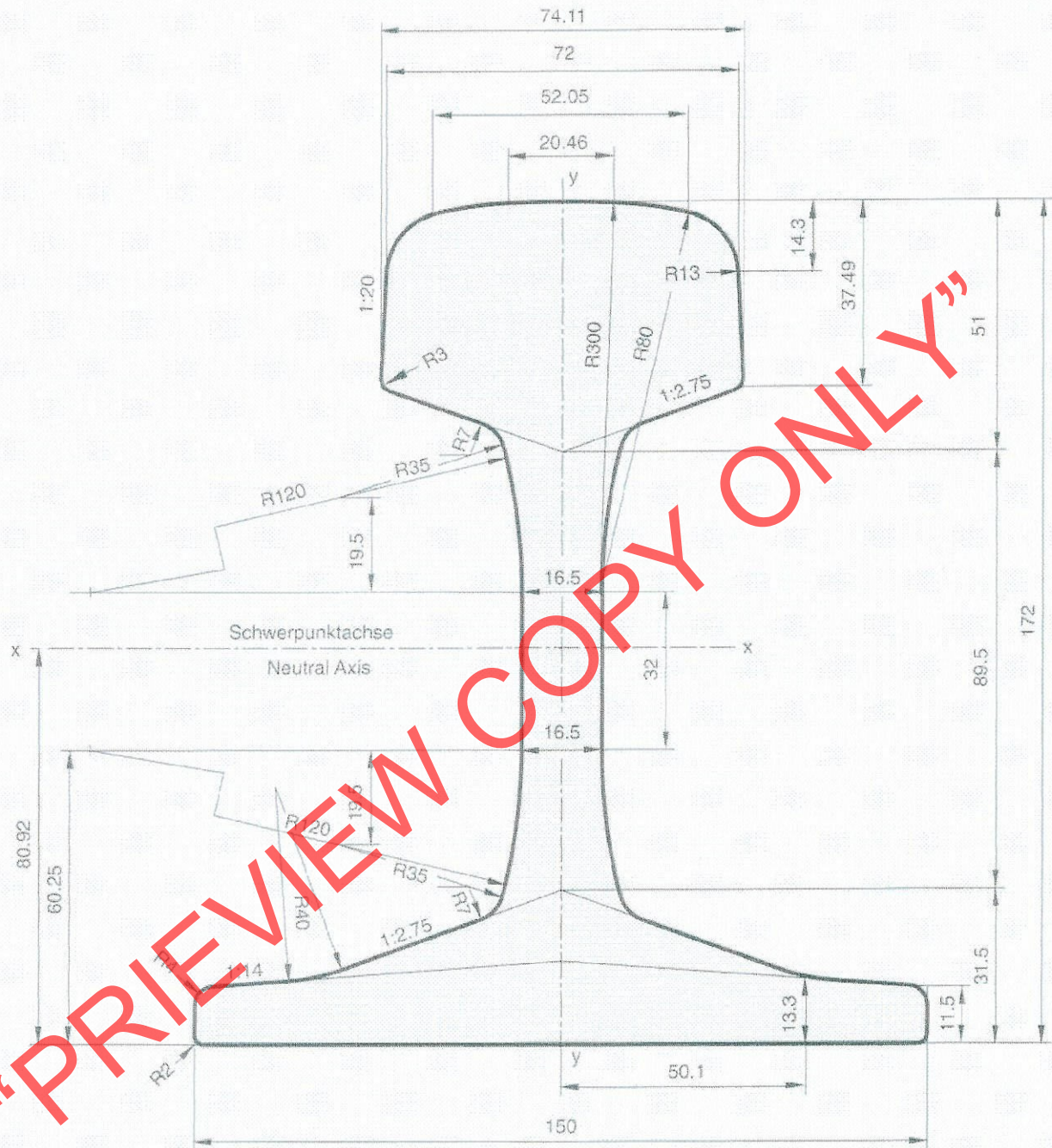

$A = 76.7 \text{ cm}^2$   
 $G = 60.21 \text{ kg/m}$   
 $I_x = 3038.3 \text{ cm}^4$   
 $W_x = 333.6 \text{ cm}^3$

Scale: 1 : 1.25  
 Edition: 8/97



RAIL PROPERTIES

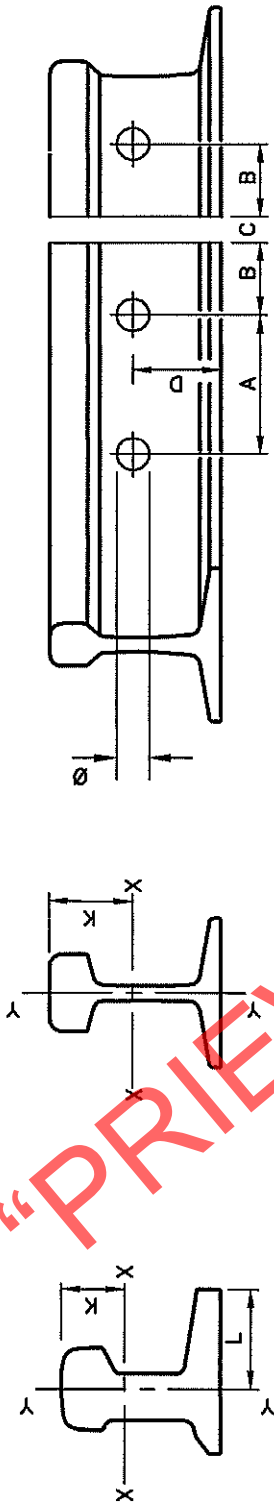

RAIL	MASS (kg/m)	HOLING							AREAS					PROPERTIES				
		A	B	C	D	Ø	NUMBER	HEAD (%)	WEB (%)	FLANGE SECTION (%)	I (cm <sup>4</sup> )	Z (cm <sup>3</sup> )	K (mm)	L (mm)	DRAWING			
																X - X	Y - Y	
30kg	30	100	47	6	46	26	4	45,11	18,87	36,02	38,537	626,89	158,18	110,94	56,36	-	E-192M	
40kg	40	100	47	6	54	26	4	44,86	19,44	35,70	51,715	1 115,38	281,56	169,20	65,92	-	E-346	
43kg	43	100	47	6	54	26	4	42,42	24,03	33,55	55,230	1 129,00	280,30	170,10	66,35	-	E-3215M	
48kg	48	100	67	6	66	32	4	41,55	22,65	35,80	60,160	1 822,00	316,04	234,18	78,50	-	E-358M	
51kg	51	100	67	6	66	32	4	39,00	27,80	33,20	64,650	1 844,00	320,50	234,60	78,60	-	E-358M	
57kg	57	100	67	6	70	35	4	41,55	23,02	35,43	73,240	2 650,80	442,00	336,46	86,21	-	E-3232M	
60kg	60	100	67	6	70	35	4	40,14	25,69	34,17	76,125	2 703,27	445,39	343,97	86,41	-	E-3232M	
S-60-SAR	60,34	100	67	6	78	35	4	37,53	24,02	38,45	77,020	3 097,82	550,40	395,63	93,70	-	E-3326	
Z-S60-SAR	72,83	-	-	-	-	-	-	34,88	30,63	34,47	92,980	1 734,40	746,94	292,98	74,80	82,70	-	
UIC-60	60,34	100	67	6	76,25	35	4	40,22	22,55	37,23	76,860	3 055,00	512,90	355,50	91,05	-	700-E-736	
Zu-1-60	73,00	-	-	-	-	-	-	-	-	-	93,000	1 728,00	743,50	229,90	75,15	82,24	-	
S-49	49,43	100	67	6	62,5	35	4	47,45	17,56	34,99	62,970	1 189,00	320,00	240,00	75,70	-	700-E-722	
Zu-2-49	62,20	-	-	-	-	-	-	-	-	-	79,260	1 075,00	700,00	162,00	66,30	81,00	-	